

# TPS65381-Q1 Multirail Power Supply for Microcontrollers in Safety-Relevant Applications

*Not Recommended for New Designs*

## 1 Device Overview

### 1.1 Features

- **Qualified for Automotive Applications**
- **AEC-Q100 Qualified With the Following Results:**
  - Device Temperature Grade 1: –40°C to +125°C Ambient Operating Temperature
  - Device HBM ESD Classification Level H2
  - Device CDM ESD Classification Level C3B
- **Multirail Power Supply Supporting Among Others**
  - TI Hercules™ TMS570, C2000™, and Various Functional-Safety Architecture Microcontrollers
- **Supply Rails**
  - Input voltage range:
    - 5.8 V to 36 V (CAN, I/O, MCU Core, and Sensor-Supply Regulators Functional)
    - 4.5 V to 5.8 V (3.3 V I/O and MCU Core Regulators Functional)
  - 6-V Asynchronous Switch Mode Preregulator With Internal FET, 1.3-A Output Current
  - 5-V (CAN) Supply Voltage, Linear Regulator With Internal FET, 300-mA Output Current
  - 3.3-V or 5-V (MCU I/O) Voltage, Linear Regulator With Internal FET, 300-mA Output Current
  - 0.8-V to 3.3-V Adjustable (MCU Core Voltage), Linear Regulator Controller With External FET
  - 3.3-V to 9.5-V Adjustable Sensor Supply: Linear Tracking Regulator With Internal FET, 100-mA Output Current, and Protection Against Short-to-Supply and Short-to-Ground
  - Charge Pump: Typically 12 V Above Battery Voltage
- **Power Supply and System Monitoring**
  - Independent Undervoltage and Overvoltage Monitoring on All Regulator Outputs, Battery Voltage, and Internal Supplies
  - Independent Voltage References for Regulator References and Voltage Monitoring. Voltage-Monitoring Circuitry With Independent Bandgap Reference and Separate Supply Input Pin
  - Self-Check on all Voltage Monitoring (Automatic During Power-Up and After Power-Up Initiated by External MCU)
  - All Supplies With Internal FETs Protected With Current-Limit and Overtemperature Shutdown
- **Microcontroller (MCU) Interface**
  - Watchdog: Trigger Mode (OPEN/CLOSE Window) or Question and Answer Mode
  - MCU Error-Signal Monitor For Lock-Step Dual-Core MCUs Including Hercules™ TMS570, C2000™, and Various Functional-Safety Architecture MCUs Using Pulse-Width Modulation (PWM) Error Output
  - DIAGNOSTIC State for Performing Device Self-Tests, Diagnostics, and External Interconnect Checks
  - SAFE State for Device and System Protection on Error Event Detection
  - Clock Monitor for Internal Oscillator
  - Self-Tests for Analog- and Digital-Critical Circuits Executed With Every Device Power Up or Activated by MCU in DIAGNOSTIC State
  - CRC on Nonvolatile Memory, Device and Configuration Registers
  - Reset Circuit and Output Pin for MCU
  - Diagnostic Output Pin Allowing MCU to Observe Through a Multiplexer Internal Analog and Digital Signals of the Device
- **Serial Peripheral Interface (SPI)**
  - Configuration Registers
  - Watchdog Question and Answers
  - Diagnostic Status Readout
  - Compliant With 3.3-V and 5-V Logic Levels
- **Enable Drive Output for Disabling Safing-Path or External Power-Stages on Detected System-Failure**
- **Wakeup Through IGNITION Pin or CAN WAKEUP Pin**
- **Package: 32-Pin HTSSOP PowerPAD™ IC Package**



## 1.2 Applications

- **Safety Automotive Applications**
  - Power Steering: Electrical Power Steering (EPS) and Electro Hydraulic Power Steering (EHPS)
  - Braking: Anti-Lock Brake System (ABS), Electronic Stability Control (ESC), and Electric Parking Brake
  - Advanced Driver Assistance Systems (ADAS)
  - Suspension
- **Industrial Safety Applications**
  - Safety Programmable-Logic Controllers (PLCs)
  - Safety I/O Control Modules
  - Test and Measurement
  - Railway and Subway Signal Control and Safety Modules
  - Elevator and Escalator Safety Control
  - Wind Turbine Control

## 1.3 Description

The TPS65381-Q1 device is a multirail power supply designed to supply microcontrollers (MCUs) in safety-relevant applications, such as those found in automotive and industrial markets. The device supports Texas Instruments' Hercules™ TMS570 MCU and C2000™ MCU families, and various other MCUs with dual-core lockstep (LS) or loosely-coupled architectures (LC).

The TPS65381-Q1 device integrates multiple supply rails to power the MCU, controller area network (CAN), or FlexRay, and an external sensor. An asynchronous-buck switch-mode power-supply converter with an internal FET converts the input supply (battery) voltage to a 6-V preregulator output. This 6-V preregulator supplies the other regulators. The device supports wakeup from IGNITION or wakeup from the CAN transceiver.

The integrated, fixed 5-V linear regulator with internal FET can be used for a CAN or FlexRay transceiver supply for example. A second linear regulator, also with an internal FET, regulates to a selectable 5-V or 3.3-V output which, for example, can be used for the MCU I/O voltage.

The TPS65381-Q1 device includes an adjustable linear-regulator controller, requiring an external FET and resistor divider, that regulates to an adjustable voltage of between 0.8 V and 3.3 V which may be used for the MCU core supply.

The integrated sensor supply can be run in tracking mode or adjustable output mode and includes short-to-ground and short-to-battery protection. Therefore, this regulator can power a sensor outside the module or electronic control unit (ECU).

The integrated charge pump provides overdrive voltage for the internal regulators. The charge pump can also be used in a reverse-battery protection circuit by using the charge-pump output to control an external NMOS transistor. This solution allows for a lower minimum-battery-voltage operation compared to a traditional reverse-battery blocking diode when the device must be operational at the lowest possible supply voltages.

The device monitors undervoltage and overvoltage on all regulator outputs, battery voltage, and internal supply rails. A second bandgap reference, independent from the main bandgap reference, is used for the undervoltage and overvoltage monitoring, to avoid any drifts in the main bandgap reference from being undetected. In addition, regulator current-limits and temperature protections are implemented.

The TPS65381-Q1 device has monitoring and protection functions, which include the following: watchdog with trigger and *question and answer* modes, MCU error-signal monitor, clock monitoring on internal oscillators, self-check on the clock monitor, cyclic redundancy check (CRC) on nonvolatile memory, a diagnostic output pin allowing the MCU to observe internal analog and digital signals of the device, a reset circuit and output pin for the MCU, and an enable drive output to disable the safing-path or external-power stages on detected faults. A built-in self-test (BIST) monitors the device functionality automatically at power-up. A dedicated DIAGNOSTIC state allows the MCU to check TPS65381-Q1 monitoring and protection functions.

The TPS65381-Q1 device is offered in a 32-pin HTSSOP PowerPAD package.

Device Information<sup>(1)</sup>

PART NUMBER	PACKAGE	BODY SIZE (NOM)
TPS65381-Q1	HTSSOP (32)	11.00 mm x 6.20 mm

(1) For all available packages, see the orderable addendum at the end of the data sheet.

1.4 Typical Application Diagram

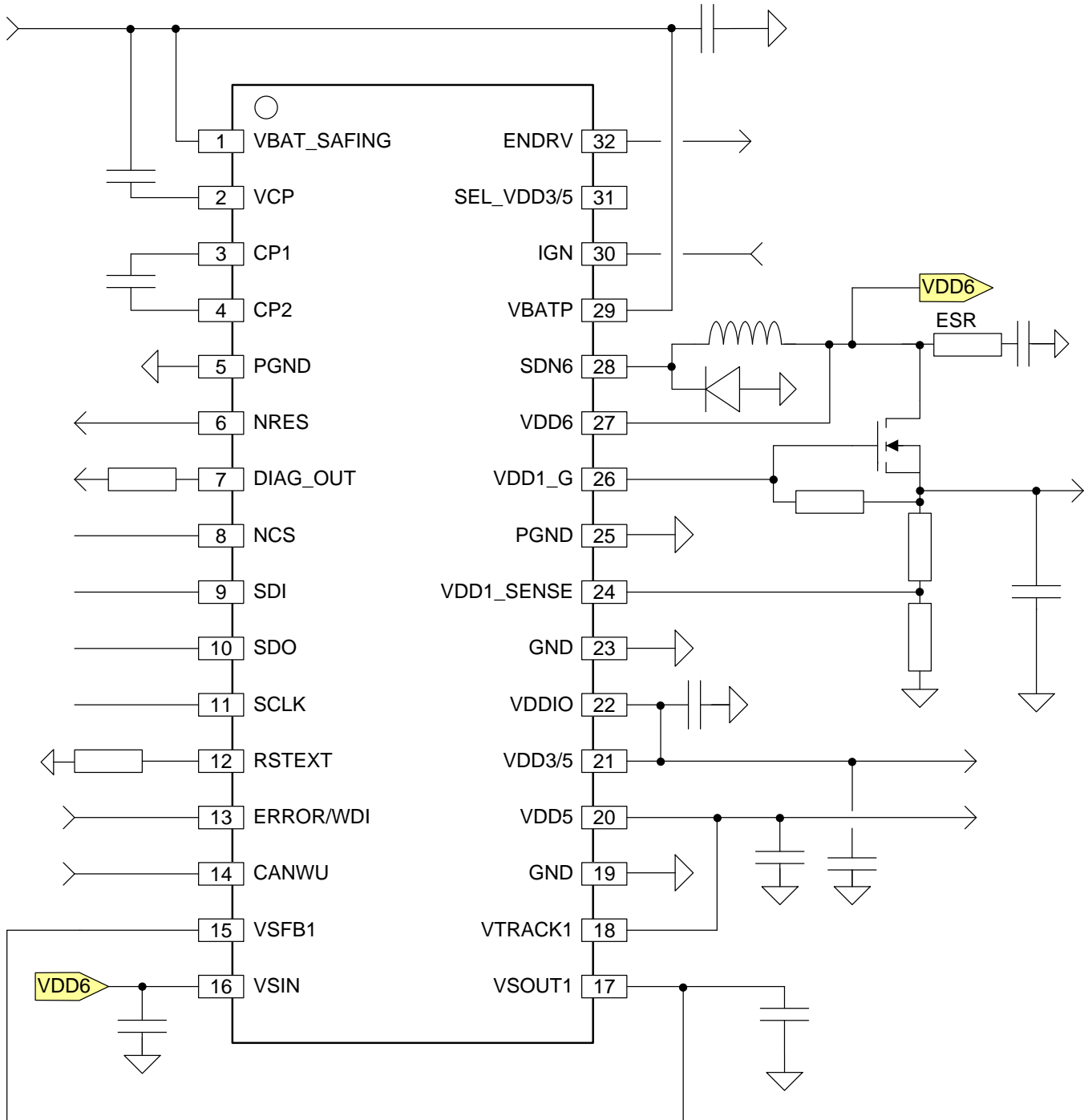

Copyright © 2016, Texas Instruments Incorporated

Figure 1-1. Typical Application Diagram

## Table of Contents

<b>1</b>	<b>Device Overview</b> .....	<b>1</b>	5.4	Device Functional Modes .....	<b>45</b>
1.1	Features .....	<b>1</b>	5.5	Register Maps .....	<b>92</b>
1.2	Applications .....	<b>2</b>	<b>6</b>	<b>Application and Implementation</b> .....	<b>116</b>
1.3	Description .....	<b>2</b>	6.1	Application Information .....	<b>116</b>
1.4	Typical Application Diagram .....	<b>3</b>	6.2	Typical Application .....	<b>116</b>
<b>2</b>	<b>Revision History</b> .....	<b>4</b>	6.3	System Examples .....	<b>124</b>
<b>3</b>	<b>Pin Configuration and Functions</b> .....	<b>27</b>	<b>7</b>	<b>Power Supply Recommendations</b> .....	<b>129</b>
<b>4</b>	<b>Specifications</b> .....	<b>29</b>	<b>8</b>	<b>Layout</b> .....	<b>129</b>
4.1	Absolute Maximum Ratings .....	<b>29</b>	8.1	Layout Guidelines .....	<b>129</b>
4.2	ESD Ratings .....	<b>29</b>	8.2	Layout Example .....	<b>131</b>
4.3	Recommended Operating Conditions .....	<b>30</b>	8.3	Power Dissipation and Thermal Considerations .....	<b>132</b>
4.4	Thermal Information .....	<b>31</b>	<b>9</b>	<b>Device and Documentation Support</b> .....	<b>134</b>
4.5	Electrical Characteristics .....	<b>32</b>	9.1	Device Support .....	<b>134</b>
4.6	Timing Requirements .....	<b>36</b>	9.2	Documentation Support .....	<b>134</b>
4.7	Switching Characteristics .....	<b>37</b>	9.3	Receiving Notification of Documentation Updates .....	<b>134</b>
4.8	Typical Characteristics .....	<b>38</b>	9.4	Community Resources .....	<b>134</b>
<b>5</b>	<b>Detailed Description</b> .....	<b>39</b>	9.5	Trademarks .....	<b>134</b>
5.1	Overview .....	<b>39</b>	9.6	Electrostatic Discharge Caution .....	<b>135</b>
5.2	Functional Block Diagram .....	<b>39</b>	9.7	Glossary .....	<b>135</b>
5.3	Feature Description .....	<b>40</b>	<b>10</b>	<b>Mechanical, Packaging, and Orderable Information</b> .....	<b>135</b>

## 2 Revision History

NOTE: Page numbers for previous revisions may differ from page numbers in the current version.

Changes from Revision F (May 2016) to Revision G	Page
• Changed the Features list for Supply rails to show output current instead of current limit. Added general current limit bullet in the <i>FEATURES</i> list .....	<b>1</b>
• Added acronym definitions .....	<b>1</b>
• Changed recommended maximum voltage for VBATP and VBAT_SAFING in the <i>Recommended Operating Conditions</i> table .....	<b>8</b>
• Changed the PIN Function table descriptions to clarify device operation .....	<b>27</b>
• Changed the max value for the charge-pump voltages from 52 V to lesser of VBATP + 16V or 52 V with footnote in the <i>ABSOLUTE MAXIMUM RATINGS</i> table .....	<b>29</b>
• Changed M1.12 and M1.13 Sensor supply feedback and supply voltage by combining in M1.12 with conditions of use for the Sensor supply output and feedback voltage to match how the sensor supply is used. Changed the maximum to 18 V in the <i>ABSOLUTE MAXIMUM RATINGS</i> table .....	<b>29</b>
• Deleted M1.13 Sensor supply output voltage by combining with M1.12 in the <i>ABSOLUTE MAXIMUM RATINGS</i> table .....	<b>29</b>
• Changed the table note for <i>Absolute Maximum Ratings</i> .....	<b>29</b>
• Changed recommended operating condition descriptions for R1.1, R1.2 and R1.3 to make the operation of device more clear in the <i>Recommended Operating Conditions</i> .....	<b>30</b>
• Deleted recommended operating condition R1.3a and R1.3b, VBAT_SAFING impact to device operation was included in R1.2 and R1.3 to make the operation of device more clear in the <i>Recommended Operating Conditions</i> .....	<b>30</b>
• Changed link formats throughout document .....	<b>30</b>
• Changed recommended maximum voltage for VBATP and VBAT_SAFING in the <i>Recommended Operating Conditions</i> table .....	<b>30</b>
• Changed the Thermal Metric table and Derating Profile for Power Dissipation Based on High-K JEDEC PCB in the <i>Thermal Information</i> section .....	<b>31</b>
• Changed application report link .....	<b>31</b>
• Changed the Derating Profile for the Power Dissipation in the <i>Thermal Information</i> table and the <i>Power Dissipation and Thermal Considerations</i> section .....	<b>31</b>
• Deleted R1.3b from the operating conditions in the <i>Electrical Characteristics</i> section since VBAT_SAFING condition R1.3b was merged with R1.2 in the <i>Recommended Operating Conditions</i> , <i>Timing Requirements</i> and	

Switching Characteristics sections .....	<a href="#">32</a>
• Changed VDD6, POS 1.1 to only volts as units for consistency in the <i>ELECTRICAL CHARACTERISTICS</i> table ....	<a href="#">32</a>
• Deleted Hysteresis parameter from $T_{prot_{VDD6}}$ (POS 1.7) in the <i>ELECTRICAL CHARACTERISTICS</i> table. ....	<a href="#">32</a>
• Changed VDD5, POS 2.1 to only volts as units for consistency in the <i>ELECTRICAL CHARACTERISTICS</i> table ....	<a href="#">32</a>
• Changed POS 2.3 test condition to Load step 20% to 80% in 5 $\mu$ s, with $C_{VDD5} = 5 \mu$ F for VDD5 output voltage dynamic parameter in the <i>Electrical Characteristics</i> table .....	<a href="#">32</a>
• Changed PSRR to > 40 dB typical n the <i>Electrical Characteristics</i> for parameter 2.6 .....	<a href="#">32</a>
• Deleted Hysteresis parameter from $T_{prot_{VDD5}}$ (POS 2.13) in the <i>ELECTRICAL CHARACTERISTICS</i> table. ....	<a href="#">32</a>
• Changed all references of VDD3_5 to VDD3/5 for consistency in the datasheet .....	<a href="#">32</a>
• Added clarification on VDD6 current limit and duty cycle in the <i>Electrical Characteristics</i> section.....	<a href="#">32</a>
• Added clarification on $I_{VDD5\_limit}$ current limit in the <i>Electrical Characteristics</i> section .....	<a href="#">32</a>
• Changed VDD3/5, POS 3.1 to only volts as units for consistency in the <i>ELECTRICAL CHARACTERISTICS</i> table..	<a href="#">33</a>
• Changed POS 3.3 into 3.3a for 3.3 V setting and 3.3v for 5 V setting for VDD3/5 output voltage dynamic parameter in the <i>Electrical Characteristics</i> table .....	<a href="#">33</a>
• Changed POS 3.3a and 3.3b test condition to Load step 20% to 80% in 5 $\mu$ s, with $C_{VDD3/5} = 5 \mu$ F for VDD3/5 output voltage dynamic parameter in the <i>Electrical Characteristics</i> table .....	<a href="#">33</a>
• Changed the minimum for POS 3.3a from 3.17 V to 3.15 V, VDD3/5 output voltage dynamic parameter in the <i>Electrical Characteristics</i> table.....	<a href="#">33</a>
• Changed PSRR to > 40 dB typical n the <i>Electrical Characteristics</i> for parameter 3.6 .....	<a href="#">33</a>
• Deleted Hysteresis parameter from $T_{prot_{VDD3/5}}$ (POS 3.13) in the <i>ELECTRICAL CHARACTERISTICS</i> table. ....	<a href="#">33</a>
• Changed MAX value of $VDD1_{SENSE(4.2)}$ from 0.816 mV to 0.808 mV in the <i>Electrical Characteristics</i> table .....	<a href="#">33</a>
• Changed $VDD1_{SENSE}$ POS 4.2 to only volts as units for consistency in the <i>ELECTRICAL CHARACTERISTICS</i> table .....	<a href="#">33</a>
• Changed $VDD1_{dyn}$ , POS 4.7, to typical due to dependency on external FET choice in the <i>Electrical Characteristics</i> table .....	<a href="#">33</a>
• Changed the $VDD1_{max}$ , POS 4.8, to specific VDD1 output voltage range for test condition in the <i>Electrical Characteristics</i> table .....	<a href="#">33</a>
• Changed PSRR to > 40 dB typical n the <i>Electrical Characteristics</i> for parameter 4.9 .....	<a href="#">33</a>
• Added clarification on $I_{VDD3/5}$ load current at power up in the <i>Electrical Characteristics</i> section.....	<a href="#">33</a>
• Added clarification on $I_{VDD3/5\_limit}$ current limits in the <i>Electrical Characteristics</i> section .....	<a href="#">33</a>
• Changed $MVVSOUT1$ min and max values from –25 and 25 to –35 and 35 in the <i>ELECTRICAL CHARACTERISTICS</i> table.....	<a href="#">34</a>
• Changed VSFB1, POS 5.3 to only volts as units for consistency in the <i>ELECTRICAL CHARACTERISTICS</i> table...	<a href="#">34</a>
• Changed Test Condition and PSRR to > 40 dB typical sensor supply to clarify the test in the <i>Electrical Characteristics</i> for parameters 5.6 .....	<a href="#">34</a>
• Changed POS 5.11, $VSOUT1_{SH}$ , for clarity of condition for output short circuit voltage range and changed maximum voltage to 18 V in the <i>ELECTRICAL CHARACTERISTICS</i> table .....	<a href="#">34</a>
• Deleted Hysteresis parameter from $T_{prot_{VSOUT1}}$ (POS 5.13) in the <i>ELECTRICAL CHARACTERISTICS</i> table. ....	<a href="#">34</a>
• Changed $I_{VSOUT1\_limit}$ , POS 5.14 minimum from 100 mA to 120 mA in the <i>ELECTRICAL CHARACTERISTICS</i> table .....	<a href="#">34</a>
• Added clarification on $I_{VSOUT1}$ load current and power dissipation in the <i>Electrical Characteristics</i> section.....	<a href="#">34</a>
• Changed min value for $VDD3/5_{UVhead}$ to 155 mV from 170 mV for 3.3-V setting in the <i>ELECTRICAL CHARACTERISTICS</i> table POS 6.13 .....	<a href="#">35</a>
• Changed $VDD_{UV}$ POS 6.16 units from ratio to mV for consistency in the <i>ELECTRICAL CHARACTERISTICS</i> table .....	<a href="#">35</a>
• Changed $VDD1_{OV}$ POS 6.17 MIN from 824 mV to 816 mV in the <i>ELECTRICAL CHARACTERISTICS</i> table.....	<a href="#">35</a>
• Changed $VDD1_{OV}$ POS 6.17 units from ratio to mV for consistency in the <i>ELECTRICAL CHARACTERISTICS</i> table .....	<a href="#">35</a>
• Deleted $VSOUT1_{UV}$ hysteresis parameter (typical), POS 6.19a in the <i>ELECTRICAL CHARACTERISTICS</i> table..	<a href="#">35</a>
• Deleted $VSOUT1_{OV}$ hysteresis parameter (typical), POS 6.20a in the <i>ELECTRICAL CHARACTERISTICS</i> table..	<a href="#">35</a>
• Changed $I_{IGN\_rev}$ parameter (7.4), -1, from MAX to MIN to match polarity in the <i>ELECTRICAL CHARACTERISTICS</i> table .....	<a href="#">35</a>
• Changed $I_{CAN\_rev}$ parameter (7.8), -1, from MAX to MIN to match polarity in the <i>ELECTRICAL CHARACTERISTICS</i> table .....	<a href="#">35</a>
• Added clarification to POS 10.1, 10.2 and 10.3 by using pin names in parameter field instead of footnote and adding $SEL_{VDD3/5}$ pin to 10.1 and 10.2 in the <i>ELECTRICAL CHARACTERISTICS</i> table .....	<a href="#">36</a>
• Changed $t_{delay_{VDD5}}$ max from 2.5 ms to 5 ms in the <i>Timing Requirements</i> table .....	<a href="#">36</a>
• Changed $t_{delay_{VDD3/5}}$ max from 2.5 ms to 5 ms in the <i>Timing Requirements</i> table .....	<a href="#">36</a>
• Changed $t_{delay_{VDD1}}$ max from 2.5 ms to 5 ms in the <i>Timing Requirements</i> table .....	<a href="#">36</a>
• Changed $VBATP_{degitch}$ minimum from 200 $\mu$ s to 180 $\mu$ s and maximum from 280 $\mu$ s to 260 $\mu$ s in the <i>Timing Requirements</i> table for POS 6.7.....	<a href="#">36</a>

- Changed minimum for  $t_{WD\_pulse}$  in the *ELECTRICAL CHARACTERISTICS* table to 14.25  $\mu s$  from 28  $\mu s$  ..... [37](#)
- Deleted  $t_{ERROR\_WDI\_deglitch}$  in the *ELECTRICAL CHARACTERISTICS*  $\mu s$  ..... [37](#)
- Changed min value for  $t_{high}$  (13.3) to 85.7 ns in the *ELECTRICAL CHARACTERISTICS* table. .... [37](#)
- Changed format of graph ..... [38](#)
- Added clarification of operation in the *VDD6 Buck Switch Mode Power Supply* section ..... [40](#)
- Added a note to the VSOUT1 register clarifying VSOUT1\_EN through RESET state in the *VSOUT1 Linear Regulator* section..... [43](#)
- Added note in the *Wake-Up* section to not send WR\_CAN\_STBY command while CANWU and/or IGN are still high. .... [43](#)
- Changed WDT\_FAIL\_CNT and WD\_FAIL\_CNT to WD\_FAIL\_CNT[2:0] throughout document ..... [45](#)
- Changed section heading levels from 5.4.1.1 through 5.4.1.20..... [47](#)
- Changed the VCP17\_OV *impact on device behavior in the Voltage Monitoring Overview* table and the *Internal Errors Signals* table. .... [48](#)
- Changed the VCP12\_OV the *impact on device behavior in the Voltage Monitoring Overview* table and the *Internal Errors Signals* table. .... [48](#)
- Changed the MAIN\_BG and VMON\_BG UV and OV *impact on device behavior in the Voltage Monitoring Overview* table and the *Internal Errors Signals* table. .... [48](#)
- Changed all \_UVN Signal Names in the *Internal Error Signals* table and *Digital MUX* section to Nxxx\_UV for consistency in datasheet for inverted logic signal names with N at the beginning of the name. .... [49](#)
- Changed the signal name from VCP\_OV to VCP17\_OV for D1.7 in the *Internal Error Signals* table. Also changed the device state from *Not changed* for NRES and ENDRV to *LOW*, and State to *STANDBY* ..... [49](#)
- Changed the max deglitch for VDD5\_OT, VDD3/5\_OT and VSOUT1\_OT to 64us in the *Internal Error Signals* table ..... [50](#)
- Changed the naming convention of EN\_VDD5\_OT and EN\_VDD3/5\_OT to NMASK\_VDD5\_OT and NMASK\_VDD3/5\_OT to clarify option of these configuration bits throughout the datasheet ..... [50](#)
- Changed the description of VDD5\_OT in the *Internal Error Signals* table for clarity ..... [50](#)
- Changed the VMON\_TRIM\_ERR deglitch time minimum from 15 to 5  $\mu s$  and maximum from 30 to 10  $\mu s$  in the *Internal Error Signals* table ..... [50](#)
- Changed the VMON\_TRIM\_ERR device state when flag is set to NRES = LOW from not changed, ENDRV = LOW from not changed and Device State to STANDBY from not changed in the *Internal Error Signals* table ..... [50](#)
- Added clarification footnote to VDD5\_CL internal signal in the *Internal Error Signals* table ..... [50](#)
- Changed Analog BIST Run States diagram for to clarify operation in the *Analog Built-In Self-Test* section ..... [52](#)
- Changed ABIST\_UVOV\_ERR and ABIST\_OV\_UV to ABIST\_ERR throughout document ..... [52](#)
- Added notes to clarify considerations needed if a manual run of LBIST is done in DIAGNOSTIC or ACTIVE state in the *Logic Built-In Self-Test (LBIST)* section..... [53](#)
- Added clarification in the *Analog Built-In Self-Test (ABIST)* and *Logic Built-In Self-Test (LBIST)* sections to clarify operation ..... [54](#)
- Changed paragraphs for VSOUT1, VDD6 and VDD3/5 overtemperature and current limit in the *Junction Temperature Monitoring and Current Limiting* section to clarify device operation..... [54](#)
- Changed the descriptions in the *Overtemperature and Overcurrent Protection Overview* table to clarify device operation and made naming for thermal shutdown consistent to overtemperature ..... [55](#)
- Changed Section title to *Diagnostic MUX and Diagnostic Output Pin (DIAG\_OUT)*..... [56](#)
- Added clarity to the DIAG\_OUT description in the *Diagnostic Output Pin DIAG\_OUT* section..... [56](#)
- Added clarification to the SPI Interface Note for the use of the SPI in a bus while DIAG\_OUT MUX is enabled in the *Diagnostic Output Pin DIAG\_OUT* section ..... [56](#)
- Changed values and clarity of AMUX operation and added minimum output resistance in the *Analog MUX Selection* table ..... [57](#)
- Changed WDT\_ signal names to WD\_, WD\_RES\_EN toWD\_RST\_EN, NMASK\_VDD1\_OV to NMASK\_VDD1\_UV\_OV, and EN\_DRV to ENDRV throughout document ..... [58](#)
- Changed NRST\_EXT\_IN to NRES\_EXT\_IN for consistency with pin name ..... [58](#)
- Changed WDI/Error to Error/WDI throughout document..... [61](#)
- Changed the *Watchdog Question (Token) Generation* image in the *Watchdog Timer Configuration for Question and Answer Configuration* section ..... [70](#)
- Changed Figure for Watchdog Answer Calculation in the *Question (Token) Generation* section to remove FDBK[3:0] impact on Answer-x byte calculation ..... [71](#)
- Changed TOKEN\_ERR bit name to ANSWER\_ERR to more accurately describe the error the bit indicates throughout the datasheet ..... [72](#)
- Changed SEQ\_ERR status bit in *Table WD\_STATUS Bits Versus Possible Watchdog Sequence Events* section... [74](#)
- Added a note to clarify impact of changing SAFETY\_ERR\_PWM\_L or SAFETY\_ERR\_PWM\_H while the MCU ESM is running in the *MCU Error Signal Monitor (MCU ESM)* section ..... [75](#)

- Added a note to clarify MCU ESM diagnostics in the *MCU Error Signal Monitor (MCU ESM)* section ..... [76](#)
- Added clarification in the *MCU Error Signal Monitor (MCU ESM)* section ..... [76](#)
- Added clarification for the LOW minimum and maximum duration time for the MCU ESM in the *TMS570 Mode* section ..... [76](#)
- Changed the time range for HIGH and LOW pulse duration in *PWM Mode* section from 5  $\mu$ s to 15  $\mu$ s (minimum) and 1.28 ms to 3.8 ms (maximum) for consistency along with additional clarifications of operation ..... [78](#)
- Added clarification for HIGH and LOW pulse register minimum and maximum pulse timing for the MCU ESM in the *PWM Mode* section ..... [78](#)
- Added a note to clarify MCU ESM to MCU synchronization in the *MCU Error Signal Monitor (MCU ESM) PWM Mode* section ..... [79](#)
- Added note to clarify uncleared CFG\_CRC\_ERR impact to state diagram during DIAGNOSTIC state in the list of steps in the *Device Configuration Register Protection* section ..... [83](#)
- Changed the *Reset and Enable Circuit* image to clarify operation ..... [84](#)
- Changed section title from *Device Controller State Diagram* to *Device Operating States* and clarified device operating states operation ..... [86](#)
- Changed the STANDBY, RESET, DIAGNOSTIC, ACTIVE and SAFE state text descriptions in their sections to clarify device operation. .... [87](#)
- Added clarification in the *RESET STATE* list ..... [87](#)
- Added clarification on BIST running on exit of RESET State to the *RESET STATE* section ..... [88](#)
- Added note to clarify considerations needed if a manual run of LBIST is done in the DIAGNOSTIC state in the *DIAGNOSTIC state* section ..... [89](#)
- Added note to clarify considerations needed if a manual run of LBIST is done in the ACTIVE state in the *ACTIVE state* section ..... [90](#)
- Added note to clarify SAFE state time-out possible state transitions due to the SAFE state time-out in the *SAFE state* section ..... [91](#)
- Added the Power on Reset (NPOR) section to clarify device operation. .... [91](#)
- Changed the STAT[2] and STAT[0] descriptions for SPI errors in the *Device Status Flag Byte Response* table ..... [93](#)
- Added note to explain additional SPI diagnostics in the *Device Status Flag Byte Response* section ..... [93](#)
- Added SPI Register Write Access Lock (SW\_LOCK command) section in the *Register Map* section ..... [94](#)
- Added clarification on which registers are re-initialized to default values after LBIST run in *Register Map* section .. [95](#)
- Added clarification to WR\_CAN\_STBY that this command is only valid with data 00h in the *SPI Command Table* .. [95](#)
- Deleted note "SPI WR update can occur only in the DIAGNOSTIC and ACTIVE states" for WR\_SAFETY\_BIST\_CTRL command in the *SPI Command Table* ..... [95](#)
- Changed SAFE\_CFG\_CRC to SAFETY\_CFG\_CRC throughout the datasheet for consistency of the register name ..... [96](#)
- Changed register bit descriptions in the *DEV\_CFG2 Register* table to clarify device operation ..... [99](#)
- Added clarification on VDD5\_UV operation when VDD5\_EN = 0 in the *VMON\_STAT\_2 Register* ..... [101](#)
- Added clarity to note on VDD5\_ILIM bit description in the *SAFETY\_STAT\_1 Register* table ..... [102](#)
- Changed the D[5] NRES\_ERR, LBIST\_ERR, ABIST\_ERR, LBIST\_RUN and ABIST\_RUN register descriptions in *SAFETY\_STAT\_3 Register* ..... [104](#)
- Added to the NRES\_ERR description in the *SAFETY\_STAT\_3 Register* table ..... [104](#)
- Changed the SPI\_ERR[1:0] description in the *SAFETY\_STAT\_4 Register* table ..... [105](#)
- Changed the LOCLK description in the *SAFETY\_STAT\_4 Register* table ..... [105](#)
- Changed MCU\_ERR bit description in *SAFETY\_STAT\_4 Register* table ..... [105](#)
- Changed WD\_ERR bit and NRES\_ERR bit description in *SAFETY\_STAT\_4 Register* table to clarify operation ..... [105](#)
- Deleted note "Write update can only occur in the DIAGNOSTIC and ACTIVE states." for WR\_SAFETY\_BIST\_CTRL command in the *SAFETY\_BIST\_CTRL Register* ..... [107](#)
- Changed SAFETY\_STATUS\_2 to SAFETY\_STAT\_2 for consistency in the datasheet ..... [107](#)
- Changed NO\_ERROR bit description to improve clarity in the *SAFETY\_CHECK\_CTRL Register* table ..... [108](#)
- Changed ERROR\_PIN\_FAIL bit description in the *SAFETY\_ERR\_STAT Register* table ..... [110](#)
- Changed to clarify the WD\_FAIL bit description in the *SAFETY\_ERR\_STAT Register* table ..... [110](#)
- Changed ERR\_CNT to DEV\_ERR\_CNT[3:0] throughout datasheet for consistency in naming. .... [111](#)
- Added clarification on the TOKEN\_SEED[3:0] to the description in the *WD\_TOKEN\_FDBCK Register* table ..... [113](#)
- Changed WD\_FAIL\_TH description in the *WDT\_TOKEN\_VALUE Register* table for consistency ..... [114](#)
- Changed added clarification on clearing of the ANSWER\_ERR bit in the *WD\_STATUS Register* table ..... [114](#)
- Deleted "This bit is set to 1 when switching between the Trigger and Q&A Mode" and added clarification on how to clear the WD\_CFG\_CHG bit description in the *WD\_STATUS Register* table ..... [114](#)
- Changed TIME\_OUT bit description in the *WD\_STATUS Register* table to clarify how the bit is cleared. .... [114](#)
- Added ANSWER\_EARLY bit operation during trigger mode to the *WD\_STATUS Register* table ..... [114](#)
- Changed the description of VDD\_EN in the *SENS\_CTRL Register* table ..... [115](#)

- Changed the description of VSOUT1\_EN in the *SENS\_CTRL Register* table ..... [115](#)
- Clarified capacitors, resistor tolerance impact on regulation and monitoring in the *Typical Application Diagram* .... [117](#)
- Clarified resistor tolerance impact on regulation and monitoring in the *VDD1 Linear Controller* Section ..... [119](#)
- Clarified resistor tolerance impact on regulation and monitoring in the *Alternative Use for VSOUT1 Tracking Linear Regulator, Configured for 6-V Output Tracking VDD3/5 In 3.3-V Mode* Section..... [121](#)
- Clarified resistor tolerance impact on regulation and monitoring in the *Alternative Use for VSOUT1 Tracking Linear Regulator, Configured for 9-V Output Tracking to 5-V Input from VDD5* Section..... [122](#)
- Clarified resistor tolerance impact on regulation and monitoring in the *Alternative Use for VSOUT1 Tracking Linear Regulator, Configured in Non-tracking Mode Providing a 4.5-V Output* Section..... [123](#)
- Changed and clarified the *System Examples drawings* ..... [124](#)
- Changed and clarified the *Software Flowchart for Configuring and Synchronizing the MCU With the Watchdog in Q&A Mode* flowchart ..... [127](#)
- Changed and clarified the *Software Flowchart for Configuring and Synchronizing the MCU With the Watchdog in Trigger Mode* flowchart..... [128](#)
- Added Power Dissipation and Thermal Considerations in the *Layout* section ..... [132](#)
- Added *Receiving Notification of Documentation Updates* section ..... [134](#)
- Changed the *Electrostatic Discharge Caution* statement..... [134](#)

**Changes from Revision E (July 2015) to Revision F**

**Page**

- Added clarity to the PIN Function table descriptions ..... [27](#)
- Added clarification in *Recommended Operating Conditions* that GND = PGND ..... [30](#)
- Changed <sup>(1)</sup>maximum VBAT\_SAFING to 36 V in the *Recommended Operating Conditions* table for parameter 1.3a to be consistent with VBATP ..... [30](#)
- Added VBAT\_SAFING input supply voltage range for normal operation *RECOMMENDED OPERATING CONDITIONS* table ..... [30](#)
- Added clarification in statement for the *ELECTRICAL CHARACTERISTICS* table by adding VBAT\_SAFING recommended operating range in addition to VBATP recommended operating range ..... [32](#)
- Changed description of parameter from Test Condition column to a footnote on the parameter in *Electrical Characteristics* table for parameters 1.2, 1.7, 2.1, 2.13, 3.1, 3.2, 3.13, 4.2, 5.1, 5.2, 5.3, 5.13, 6.4, 6.5, 6.7, 6.22, 6.23 ..... [32](#)
- Added clarification on direct loading of VDD6 in the I<sub>VDD6</sub> *Electrical Characteristics* table ..... [32](#)
- Changed the Test Condition column to parameter description the *ELECTRICAL CHARACTERISTICS* table for 2.2, 3.1, 3.2, 5.1, 5.3a, 5.4, 9.3..... [32](#)
- Added clarification on resistor divider on regulation tolerance of VDD1 in the VDD1 section of the *Electrical Characteristics* table ..... [33](#)
- Deleted test condition from T<sub>J</sub> the *Electrical Characteristics* table for 5.5 because it is same as overall electrical characteristics table ..... [34](#)
- Changed Test Condition for input to sensor supply to VSIN from VBATP in the *Electrical Characteristics* for parameters 5.6, 5.7, 5.8 ..... [34](#)
- Changed the description for indication of VBATP\_UV (6.1, 6.2) in the *ELECTRICAL CHARACTERISTICS* table. .. [34](#)
- Added the condition of VBATP = VBAT\_SAFING to 6.1, 6.2, 6.3, 6.4, 6.5, 6.8, 6.9, 6.10, 6.11, 6.12, 6.13, 6.14, 6.15, 6.16, 6.17 in the *ELECTRICAL CHARACTERISTICS* table. .... [34](#)
- Added the condition of VBATP = VBAT\_SAFING = 12 V to 7.1, 7.2, 7.3, 7.4, 7.7 and 7.8 the *ELECTRICAL CHARACTERISTICS* table..... [35](#)
- Changed test condition for the I<sub>IGN</sub> parameter (7.4) to 36 V, added clarification that VBATP = VBAT\_SAFING = 36 V in the *ELECTRICAL CHARACTERISTICS* table ..... [35](#)
- Changed test condition for the I<sub>CANWU</sub> parameter (7.7) to 36 V, added clarification that VBATP = VBAT\_SAFING = 36 V in the *ELECTRICAL CHARACTERISTICS* table ..... [35](#)
- Added clarification for C<sub>pump</sub> and C<sub>store</sub> connections in the *Charge Pump* section of the *ELECTRICAL CHARACTERISTICS* table..... [35](#)
- Changed the Test Condition for NRES output low (parameter 9.1) level from 5mA to 2mA in the *ELECTRICAL CHARACTERISTICS* table ..... [36](#)
- Added clarification in statement for the *Timing Requirements* table by adding VBAT\_SAFING recommended operating range in addition to VBATP recommended operating range ..... [36](#)

(1) The recommended maximum operating voltage for VBATP and VBAT\_SAFING is listed as 34 V, just below the overvoltage detection thresholds for VBATP, VBATP\_OV<sub>rise</sub> and VBATP\_OV<sub>fall</sub>. TI recommends enabling overvoltage detection on VBATP (default is enabled, MASK\_VBATP\_OV = 0). TI also recommends evaluating the thermal and power dissipation of the device in the application and ensure the design has adequate thermal management for operation at the necessary supply voltage level.

• Changed description of parameter from Test Condition column to a footnote on the parameter in the <i>Timing Requirements</i> table for parameters 6.7, 11.1 .....	<a href="#">36</a>
• Changed to clarify IGNITION and CAN WAKE-UP parameters (7.6 and 7.9) in <i>TIMING REQUIREMENTS</i> table ....	<a href="#">36</a>
• Added clarification in statement for the <i>Switching Characteristics</i> table by adding VBAT_SAFING recommended operating range in addition to VBATP recommended operating range .....	<a href="#">37</a>
• Added clarification of resistor divider feedback impact in the <i>VDD1 Linear Regulator</i> section .....	<a href="#">41</a>
• Changed pin name to VTRACK1 for pin determining tracking or non-tracking mode in <i>VSOUT1 Linear Regulator</i> section describing what occurs after completion of the VDDx ramp-up .....	<a href="#">42</a>
• Added note in the <i>Wake-Up</i> section on how to wake up the device for systems that need to power up and down with the power supply and do not need IGN or CANWU.....	<a href="#">44</a>
• Changed the <i>Power-Up and Power-Down Behavior</i> image for clarity .....	<a href="#">45</a>
• Changed the VDD6 UV bit to D6 from D7 in the <i>Voltage Monitoring Overview</i> table .....	<a href="#">48</a>
• Changed the name for VSOUT1 current-limit to VSOUT1_CL in the <i>Internal Error Signals</i> table .....	<a href="#">50</a>
• Changed all references to the sensor supply to VSOUT1 for consistency .....	<a href="#">50</a>
• Changed to clarify ABIST functionality in the <i>Analog Built-In Self-Test (ABIST)</i> section .....	<a href="#">52</a>
• Changed LBIST coverage in the <i>Logic Built-In Self-Test (LBIST)</i> section.....	<a href="#">53</a>
• Changed to clarify LBIST functionality in the <i>Logic Built-In Self-Test (LBIST)</i> section.....	<a href="#">53</a>
• Changed the impact on device behavior for VSOUT1 thermal protect and over current in the <i>Thermal and Over Current Protection Overview</i> table .....	<a href="#">55</a>
• Changed the name for VSOUT1 current-limit to VSOUT1_CL in the <i>Digital MUX Selection</i> table .....	<a href="#">59</a>
• Changed and clarified Watchdog timer text in the <i>Watchdog Timer (WDT)</i> section .....	<a href="#">60</a>
• Changed the all references of ERROR/WDTI pin to ERROR/WDI pin for consistency.....	<a href="#">61</a>
• Added clarification on the watchdog fail counter and reset event requirements in the <i>Watchdog Fail Counter, Status, and Fail Event</i> section.....	<a href="#">61</a>
• Added the <i>Watchdog Sequence</i> section .....	<a href="#">62</a>
• Changed and clarified the equations for watchdog WINDOW 1 and WINDOW 2 ( $t_{WOW}$ and $t_{WCW}$ ) timing <i>Watchdog Sequence</i> section .....	<a href="#">62</a>
• Added the <i>MCU to Watchdog Synchronization</i> section .....	<a href="#">63</a>
• Added note on TIME_OUT flag not latching during active SPI frame (nCS low) in the <i>Trigger Mode (Default Mode)</i> section.....	<a href="#">63</a>
• Added clarification of the impact of a bad event on the watchdog sequence in the <i>Trigger Mode Section</i> and updated the images .....	<a href="#">66</a>
• Added note on TIME_OUT flag not latching during active SPI frame (nCS low) in the <i>Q&amp;A Mode</i> section .....	<a href="#">67</a>
• Changed and clarified the watchdog in Q&A mode answer sequence requirements in the <i>Watchdog Q&amp;A Related Definitions</i> section.....	<a href="#">68</a>
• Changed the <i>Watchdog Sequence in Q&amp;A Mode</i> image in the <i>Watchdog Sequence in Q&amp;A Mode</i> section to update the Answer-3, Answer-2, Answer-1 requirements .....	<a href="#">69</a>
• Added clarification on when the watchdog Markov chain and question counter are re-initialized in the <i>Question (Token) Generation</i> section .....	<a href="#">69</a>
• Added for clarification the <i>Device Controller State Diagram</i> .....	<a href="#">86</a>
• Changed SAFETY_ERR_STATUS to SAFETY_ERR_STAT so all references to this register are consistent .....	<a href="#">88</a>
• Added clarification on using the DIAG_EXIT_MASK bit for software debug to the end of the <i>DIAGNOSTIC STATE</i> section.....	<a href="#">89</a>
• Added note to explain conditions leading to inadvert setting of SDO ERROR bit in the <i>Device Status Flag Byte Response</i> section .....	<a href="#">93</a>
• Added clarification on reserved bits (RSV) in the <i>Register Map</i> section .....	<a href="#">95</a>
• Changed DEV_STATE to DEV_STAT for <i>Device Status in Register</i> table for consistency.....	<a href="#">97</a>
• Deleted VSOUT1_ILIM in the <i>SAFETY_STAT_1 Register</i> table and made bit D3 a reserved bit (RSV).....	<a href="#">102</a>
• Changed VDD_3_5_SEL description in <i>SAFETY_FUNC_CFG Register</i> table .....	<a href="#">109</a>
• Changed and clarified the <i>WDT_TOKEN_FDBCK Register</i> table .....	<a href="#">113</a>
• Changed and clarified the <i>WDT_WIN1_CFG Register</i> table .....	<a href="#">113</a>
• Changed and clarified the <i>WDT_WIN2_CFG Register</i> table .....	<a href="#">113</a>
• Changed and clarified the <i>WDT_TOKEN_VALUE Register</i> table .....	<a href="#">114</a>
• Changed and clarified the <i>WDT_STATUS Register</i> table .....	<a href="#">114</a>
• Changed and clarified the <i>WDT_ANSWER Register</i> table .....	<a href="#">115</a>
• Changed and clarified the <i>Software Flowchart for Configuring and Synchronizing the MCU With the Watchdog in Q&amp;A Mode</i> flowchart .....	<a href="#">127</a>
• Added the <i>Software Flowchart for Configuring and Synchronizing the MCU With the Watchdog in Trigger Mode</i> flowchart .....	<a href="#">128</a>
• Added clarity for VBAT_SAFING in the <i>Power Supply Recommendations</i> section.....	<a href="#">129</a>

**Changes from Revision D (May 2015) to Revision E Page**

- Changed the maximum UV value for VDD1 from 0.97 to 0.98 in the *Voltage Monitoring Overview* table. Also updated the VDD output voltage information ..... [48](#)
- Changed the MAX value for VDD1\_UVN from 0.97 to 0.98 in the *Internal Error Signals* table. Also updated the *Device State When Flag Is Set* cells for VDD1\_UVN ..... [49](#)
- Added clarification on the watchdog fail counter and reset event requirements in the *Watchdog Enable Function* image ..... [61](#)
- Added clarification on the watchdog fail counter and reset event requirements in the *Device Controller State Diagram*..... [86](#)

**Changes from Revision C (March 2015) to Revision D Page**

- Changed  $f_{clk\_VDD6}$  POS 1.5 minimum and maximum units from % to kHz for consistency in the *ELECTRICAL CHARACTERISTICS* table ..... [32](#)
- Changed MIN value of VDD1\_SENSE(4.2) from -2% to -1% in the *Electrical Characteristics* table ..... [33](#)
- Changed MAX value of VDD1 undervoltage level (6.16) from 0.97 to 0.98 in the *Electrical Characteristics* table ... [35](#)
- Changed description of un-used VDD1 regulator in the *VDD1 Linear Regulator* section ..... [41](#)
- Added clarification in the NMASK\_VDD1\_UV\_OV description in the *DEV\_CFG1 Register* table..... [98](#)

**Changes from Revision B (July 2014) to Revision C Page**

- Changed Applications listed in the *Applications* Section ..... [2](#)
- Deleted the nominal storage temperature value of 27°C ..... [29](#)
- Changed the *Handling Ratings* to *ESD Ratings* and moved  $T_{stg}$  into the *Absolute Maximum Ratings* table ..... [29](#)
- Added clarification notes on output capacitance and ESR for VDD6 in the *ELECTRICAL CHARACTERISTICS* table ..... [32](#)
- Added the *Typical Characteristics* section ..... [38](#)
- Added clarification of ESR needed on VDD6 output capacitance in the *Functional Block Diagram* ..... [39](#)
- Added clarification on effective output capacitance and ESR in the *VDD6 Buck Switch Mode Power Supply* section ..... [40](#)
- Added clarification on the IGN and CANWU pins with respect to transients *Wake-Up* section ..... [44](#)
- Added start-up delay to VCP in the *Power-Up and Power-Down Behavior* ..... [45](#)
- Added SPI Interface Note on use of the SPI while DIAG\_OUT MUX is enabled in the *Diagnostic Output Pin DIAG\_OUT* section..... [56](#)
- Added clarification on the watchdog fail counter and reset event requirements in the *WDT Fail Counter, WDT Status, and WDT Fail Event* section ..... [61](#)
- Changed the RT bits from 4:0 to 6:0 in the  $T_{WCW}$  calculation in the *WDTI Configuration With an External Trigger Input (Default Mode)* section..... [64](#)
- Deleted the RT bits from 4:0 to 6:0 in the  $T_{WCW}$  calculation in the *Watchdog Token-Response Sequence Run* section and changed the second calculation from  $T_{WOW}$  to  $T_{WCW}$  ..... [68](#)
- Changed WDT\_ANSW\_CNT answer order in *Set of 4-Bit WD Token Values and Corresponding 8-Bit Responses* table. .... [73](#)
- Changed 4-bit watchdog answer counter to 2-bit watchdog answer counter (WDT\_ANSW\_CNT) in *Watchdog Token-Response Sequence Run and WDT\_STATUS Register Updates* section . .... [73](#)
- Deleted logic BIST activated by MCU in SAFE state in the *MCU Error Signal Monitor (MCU ESM)*..... [76](#)
- Deleted permanently text for the CRC check in the *Device Configuration Register Protection* section ..... [81](#)
- Changed CRC check to return to step one for continuous check in the *Device Configuration Register Protection* section ..... [83](#)
- Added clarification on the watchdog fail counter and reset event requirement in the *Reset and Enable Circuit* image ..... [84](#)
- Added or POST\_RUN\_RST = 1 & IGN\_PWRL = 1 & re-cranking on IGN to *Global RESET Conditions* text bubble of the *Device Controller State Diagram* image ..... [86](#)
- Added clarification on watchdog fail counter text to the watchdog reset sub-bullet in the *RESET STATE* list ..... [87](#)
- Changed status bit STAT[1] function in *Device Status Flag Byte Response* table ..... [93](#)
- Changed data for SW\_LOCK and SW\_UNLOCK commands, which were reversed in the *SPI Command Table*..... [95](#)
- Added clarification for watchdog failure in the *SAFETY\_STAT\_2 Register* table ..... [103](#)

- Added clarification for watchdog failure in the *SAFETY\_STAT\_4 Register* table ..... [105](#)
- Added ERROR/WDI text to D[5] *cleared* to description in the *SAFETY\_ERR\_STAT Register* table ..... [110](#)
- Added watchdog fail counter text to D[4] *cleared* to description in the *SAFETY\_ERR\_STAT Register* table ..... [110](#)
- Changed the calculation in the *WDT\_WIN1\_CFG Register* table ..... [113](#)
- Changed the calculation in the *WDT\_WIN2\_CFG Register* table ..... [113](#)
- Added the *Typical Application* section ..... [116](#)
- Clarified ESR needed on VDD6 output capacitance in the *Typical Application Diagram* ..... [117](#)
- Added the *System Examples* section ..... [124](#)
- Added the *Layout* section..... [129](#)

Changes from Revision A (December 2013) to Revision B	Page
• Deleted the phrase <i>safety critical</i> from the document. ....	<a href="#">1</a>
• Added device name to document title.....	<a href="#">1</a>
• Added the following to the document: <i>Device Information</i> table, <i>Power Supply Recommendations</i> section, <i>Layout</i> section, <i>Device and Documentation Support</i> , and <i>Mechanical, Packaging, and Orderable Information</i> section .....	<a href="#">2</a>
• Changed the pin type for the VDD3/5 pin from I to PWR.....	<a href="#">28</a>
• Changed the max value for the Charge-pump voltages from 50 to 52 V in the <i>ABSOLUTE MAXIMUM RATINGS</i> table .....	<a href="#">29</a>
• Added the <i>Handling Ratings</i> table, which now contains the storage temperature and ESD ratings .....	<a href="#">29</a>
• Added added <i>with respect to the GND pin</i> to the condition statement in the <i>RECOMMENDED OPERATING CONDITIONS</i> .....	<a href="#">30</a>
• Moved operating ambient temperature range from the <i>Absolute Maximum Ratings</i> table to the <i>Recommended Operating Conditions</i> table.....	<a href="#">30</a>
• Changed changed <i>no undervoltage</i> to <i>no NRES event</i> and added VSOUT to the input supply voltage range on VBATP specification in the <i>Recommended Operating Conditions</i> .....	<a href="#">30</a>
• Deleted Thermal Information table notes: all of these notes are included in the <i>IC Package Thermal Metrics</i> application report that is listed in the new table note. ....	<a href="#">31</a>
• Added the power dissipation image and notes after the <i>Thermal Information</i> table .....	<a href="#">31</a>
• Changed condition statement for the <i>ELECTRICAL CHARACTERISTICS</i> table by removing 125°C from the T <sub>A</sub> temperature range and changing T <sub>J</sub> to the maximum operating junction temperature. Removed VBATP range and added reference to R1.2 .....	<a href="#">32</a>
• Deleted letter A from beginning of POS number in the <i>VDD6-BUCK With Internal FET</i> and <i>VDD1 – LDO With External FET</i> sections of the <i>Electrical Characteristics and Timing Requirements</i> table .....	<a href="#">32</a>
• Changed the parameter name of I <sub>VDD6</sub> from output voltage to output current in the <i>Electrical Characteristics</i> table ..	<a href="#">32</a>
• Added the test condition to the dVDD5/dt parameter in the <i>ELECTRICAL CHARACTERISTICS</i> table.....	<a href="#">32</a>
• Changed the typ value from 3.35 to 3.3 and 5 for the VDD3/5 output voltage parameter in the <i>ELECTRICAL CHARACTERISTICS</i> table.....	<a href="#">33</a>
• Changed the unit from † to V for the 3.3, VDD3/5 output voltage dynamic parameter in the <i>Electrical Characteristics</i> table .....	<a href="#">33</a>
• Changed the parameter of 3.8 in the <i>Electrical Characteristics</i> table from VDD5 to VDD6.....	<a href="#">33</a>
• Changed the parameter of A4.11 in the <i>Electrical Characteristics</i> table from VBATP to VDD6.....	<a href="#">33</a>
• Changed MVVSOUT1 min and max values from –35 and 35 to –25 and 25 in the <i>Electrical Characteristics</i> table...	<a href="#">34</a>
• Changed the max value for temperature range listed in the VdrS1 parameter test condition from 165 to 150 in the <i>Electrical Characteristics</i> table .....	<a href="#">34</a>
• Changed the MIN and MAX values of the LdReg <sub>VSOUT1</sub> parameter from –25 and 25 to –35 and 35 in the <i>Electrical Characteristics</i> table .....	<a href="#">34</a>
• Changed the typical value for the VDD3/5_OV 5-V hysteresis setting from 400 to 140 in the <i>Electrical Characteristics</i> table .....	<a href="#">35</a>
• Added DC condition note to the VSOUT1_UV and VSOUT1_OV parameters in the <i>Electrical Characteristics</i> table .....	<a href="#">35</a>
• Changed max value for the R <sub>dson_ENDRV_NRES</sub> (9.2a) parameter from 86 to 40 in the <i>Electrical characteristics</i> table ..	<a href="#">36</a>
• Deleted note reference for the R <sub>RSTEXT</sub> parameter (9.3) in the <i>Electrical Characteristics</i> table .....	<a href="#">36</a>
• Changed min value from 300 to 350 for the V <sub>ENDRV_NRES_TH</sub> (9.5) parameter in the <i>ELECTRICAL CHARACTERISTICS</i> table .....	<a href="#">36</a>
• Added note reference and test condition to the V <sub>DIGIN_HIGH</sub> parameter (10.1) in the <i>ELECTRICAL CHARACTERISTICS</i> table .....	<a href="#">36</a>
• Moved timing and switching characteristics out of the <i>Electrical Characteristics</i> table and into a <i>Timing</i>	

*Requirements and Switching Requirements* table (respectively). Also moved the capacitance at C<sub>S<sub>DO</sub></sub> note to the *Timing Requirements and Switching Requirements* tables ..... [36](#)

- Changed the TYP value to the MAX value of the SPI clock frequency parameter for the VDDIO = 5 V test condition in the *Electrical Characteristics* table ..... [37](#)
- Added image reference to timing and switching requirement parameters ..... [37](#)
- Changed max value of t<sub>tri</sub> (13.11) from 25 to 53.3 in the *ELECTRICAL CHARACTERISTICS* table ..... [37](#)
- Added the *Overview* section to the *Detailed Description* section ..... [39](#)
- Moved block diagram into the *Detailed Description* section and updated block colors ..... [39](#)
- Changed the OV max value for VDD3/5 (3.3 V) from 3.63 to 3.6 in the *Voltage Monitoring Overview* table ..... [48](#)
- Added nMASK comments to the UV and OV impact on device behavior for VDD1 in the *Voltage Monitoring Overview* table ..... [48](#)
- Moved the *Internal Error Signals* table to after the *Voltage Monitoring Overview* table in the *Detailed Description* section ..... [49](#)
- Changed the TYP value for the AVDD\_UVN signal from 3.81 to 3.6 in the *Internal Error Signals* table. Also changed the device state from *Not changed* for NRES and ENDRV to *LOW*, and for State to *STANDBY* ..... [49](#)
- Changed the TYP value for the VCP12\_UVN signal from 7.32 to 7.43 in the *Internal Error Signals* table ..... [49](#)
- Changed the TYP value for the VCP12\_OV signal from 14 to 14.2 in the *Internal Error Signals* table ..... [49](#)
- Changed the typ value for VCP\_OV from 20 to 21 in the *Internal Error Signals* table ..... [49](#)
- Changed NUV on signal names to UVN throughout ..... [49](#)
- Changed the MIN value for the LOCLK signal from 0.740.7452 to 0.742 in the *Internal Error Signals* table ..... [50](#)
- Changed the VBATP\_OV MIN and MAX values from 29 to 34.7 and 32 to 36.7 (respectively) in the *Internal Error Signals* table ..... [50](#)
- Changed the device state of the VDD3\_5\_OT bit from *STANDBY* to include change ..... [50](#)
- Changed the max values for VDD5\_CL and VDD3\_5\_CL from 600 to 650 in the *Internal Error Signals* table ..... [50](#)
- Added the DVDD\_UV signal to the *Internal Error Signals* table ..... [50](#)
- Changed ..... [50](#)
- Deleted *Watchdog function configuration* from the post-BIST-reset initialization list in the *Logic Built-In Self-Test (LBIST)* section ..... [54](#)
- Changed VCP voltage range from 0.8 to 5.5 to 0.6 to 4 ..... [57](#)
- Replaced the VSFB1 sensor-supply feedback voltage row with the VSOUT1 sensor-supply voltage row in the *Analog MUX Selection Table* ..... [57](#)
- Changed VSFB1 divide ratio from 4 ± 0.5% to 1 in the *Analog MUX Selection* table. Also changed the Voltage Range from 1.226 V to 5 V ±2% to 2.5 V to 5 V ..... [57](#)
- Changed the Voltage Range / Accuracy value for both MAIN\_BG and VMON\_BG from 1.226 to 2.5 V in the *Analog MUX Selection* table ..... [57](#)
- Changed the name bit that must be configured for DIGITAL MUX mode from DIAG\_MUX to MUX\_CFG in the *Digital MUX (DMUX)* section ..... [60](#)
- Deleted *Bits INT\_CON[2:0] in DIAG\_CFG\_CTRL register must be set to 111* list item from the SDO diagnostic check sequence in the *MUX interconnect check* section ..... [60](#)
- Changed the RT bits from 4:0 to 6:0 in the T<sub>WCW</sub> calculation in the *WDTI Configuration With an External Trigger Input (Default Mode)* section ..... [64](#)
- Deleted the CLOSE window note from the *Possible Cases for Bad Watchdog Event* image and updated the image ..... [66](#)
- Added + 1 to the duration time program calculations in the *Watchdog Token-Response Sequence Run* section and changed the second calculation from T<sub>WOW</sub> to T<sub>WCW</sub> ..... [68](#)
- Changed the filter time for the ERROR/WDI deglitch from 15-s to 15-μs in the *MCU Error Signal Monitor (MCU ESM)* section ..... [76](#)
- Changed the low-pulse duration increment from 15-s to 15-μs in the *PWM Mode* section ..... [78](#)
- Changed the *Reset and Enable Circuit* figure to reflect overtemperature behavior. .... [84](#)
- Added \_UV to the NMASK\_VDD1\_OV name in the *Reset and Enable Circuit* image ..... [84](#)
- Added \_UV to the NMASK\_VDD1\_OV name in *DIAGNOSTIC and ACTIVE state* text box of the *Device Controller State Diagram* image ..... [86](#)
- Deleted WDT failure text from the first list item in the *SAFE State* section ..... [90](#)
- Moved all of the registers into one *Register Map* section ..... [95](#)
- Changed D0 from 1 to 0 in the *DEV\_REV Register* table ..... [96](#)
- Changed D1 and D0 from 0 to X in the *DEV\_STATE Register* table ..... [97](#)
- Changed the deglitched minimum time from 7.7 to 7.5 for the IGN bit description in the *DEV\_STATE* register ..... [97](#)
- Changed D7 from RSV and 1 to VDD\_3\_5\_SEL and X in the *DEV\_CFG1 Register* table ..... [98](#)
- Changed D6 from nMASK\_VDD\_UV and 1 to nMASK\_VDD\_UV\_OV and 0 in the *DEV\_CFG1 Register* table ..... [98](#)
- Changed the default value of the NMASK\_VDD1\_UV\_OV bit from 1 to 0 and the VDD1 bit value from 0 to 1 in the *DEV\_CFG1 Register* ..... [98](#)

- Changed bit D5 name from MASK\_VBAT\_OV to MASK\_VBATP\_OV in the *DEV\_CFG2 Register* table ..... [99](#)
- Changed the D[7] description when EN\_VDD3/5\_OT is set to '0' by removing the SAFETY\_STAT\_REG1, VDD6 and re-enable text in the *DEV\_CFG2 Register* table. Also changed from *when set to '0'* to *when set to '1'* ..... [99](#)
- Changed VDD6, clearing, and re-enabling text from the D[7] description when EN\_VDD3/5\_OT is set to '1' and changed to *when set to ""* in the *DEV\_CFG2 Register* table ..... [99](#)
- Changed D[3:0] description in the *DEV\_CFG2 Register* table from *bits are not read/writable* to *bits are read/writable* ..... [99](#)
- Deleted *after SPI read access* from the clear to 0 description of each bit in the *VMON\_STAT\_1 Register*..... [100](#)
- Deleted *after SPI read access* from the clear to 0 description of each bit in the *VMON\_STAT\_2 Register*..... [101](#)
- Deleted *after SPI read access* from the clear to 0 description of each bit in the *SAFETY\_STAT\_1 Register* ..... [102](#)
- Deleted *after SPI read access* from the clear to 0 description of each bit in the *SAFETY\_STAT\_2 Register* ..... [103](#)
- Added description to bit D[4] when set to one 1 when the device is the DIAGNOSTIC state ..... [103](#)
- Changed the name of bit D5 in the SAFETY\_STAT\_3 register from NRES\_IN to NRES\_ERR ..... [104](#)
- Changed the D[5] NRES\_IN, Reset input status, register description to NRES\_ERR, Reset input error and change first description for setting this bit to 1 ..... [104](#)
- Updated *cleared to 0* description of the LBIST\_ERR bit in the *SAFETY\_STAT\_3 register* ..... [104](#)
- Added DIAGNOSTIC state description for setting bit D[3] and D[2] to 1 ..... [104](#)
- Changed *SPI read access* to *internal NPOR* from the LOCLK bit description in the *SAFETY\_STAT\_4 Register* ... [105](#)
- Changed bit D7 and bit D6 from 1 to 0 in the *SAFETY\_ERR\_CFG Register* table..... [106](#)
- Changed the SAFETY\_STAT4 register bit from D4 to D5 in the ABIST\_EN[1:0] descriptions in the *SAFETY\_BIST\_CTRL Register* table ..... [107](#)
- Changed names of protected registers in the CRG\_CRC\_EN bit description in the *SAFETY\_CHECK\_CTRL Register* ..... [108](#)
- Changed monitored to not monitored in the NO\_ERROR bit description for setting this bit to 1 in the *SAFETY\_CHECK\_CTRL Register* ..... [108](#)
- Changed CTRL to CFG in the read and write commands of the *SAFETY\_FUNC\_CFG Register* ..... [109](#)
- Changed D7 from 0 to 1 in the *SAFETY\_FUNC\_CFG Register* table..... [109](#)
- Changed D4 from 1 to 0 in the *SAFETY\_FUNC\_CFG Register* table..... [109](#)
- Changed D0 from 0 to X in the *SAFETY\_FUNC\_CFG Register* table ..... [109](#)
- Updated the WD\_RST\_EN bit description for setting this bit to 0 in the *SAFETY\_FUNC\_CFG Register* ..... [109](#)
- Changed 15 seconds to 15 μs in the *SAFETY\_ERR\_PWM\_H Register* table description ..... [110](#)
- Changed the time reference amount from 15 s to 15 μs in the PWML[7:0] bit description for when ERR\_CFG is set to 0 in the *SAFETY\_ERR\_PWM\_L Register* ..... [111](#)
- Changed 5 seconds to 5 μs in the *SAFETY\_ERR\_PWM\_H Register* table description ..... [111](#)
- Deleted **Note:** *With configuration 001 setting for INT\_CON[2:0] bits* text from the SPI\_SDO description in the *DIAG\_CFG\_CTRL Register*. Also changed the 111 description of the INT\_CON[2:0] from *controlling the state of the SPI\_SDO output buffer* to *Not applicable* ..... [112](#)
- Included bit 2 to all WDT\_FAIL\_CNT bit references ..... [114](#)
- Changed command for the *WDT\_ANSWER Register* from Read to Write ..... [115](#)
- Changed the default setting of VSOUT1\_EN from 1 to in the *SENS\_CTRL Register* tabel ..... [115](#)
- Changed Moved the *Application Information* section into the *Application and Implementation* section and added product folder references ..... [117](#)

**Changes from Original (May 2012) to Revision A**

**Page**

- Changed current limit for 6-V pre-regulator from 1.5 A to 1.3 A in the *FEATURES* list ..... [1](#)
- Added current limit to the 5-V (CAN) bullet in the *FEATURES* list ..... [1](#)
- Added current limit to the 3.3-V or 5-V MCU I/O Voltage bullet in the *FEATURES* list ..... [1](#)
- Deleted reverse battery protection bullet from the *FEATURES* list ..... [1](#)
- Changed current limit from 300 mA to 100 mA in the sensor supply bullet in the *FEATURES* list ..... [1](#)
- Deleted wake-up and enable circuit bullets from the *FEATURES* list ..... [1](#)
- Added *Independent* to voltage monitoring bullet in the *FEATURES* list..... [1](#)
- Added *Independent Bandgap Reference* bullet to the *FEATURES* list..... [1](#)
- Added *Diagnostic Output Pin* bullet to the *FEATURES* list ..... [1](#)
- Added Safting-Pin and IGNITION Pin bullets to the *FEATURES* list ..... [1](#)
- Changed document status from *Product Preview* to *Production Data*..... [1](#)
- Added CAN Transceiver sentence to the second paragraph in the *DESCRIPTION* ..... [2](#)
- Changed adjustable core voltage range from 0.8 and 2.6 V to 0.8 and 3.3 V in the *DESCRIPTION*..... [2](#)
- Added diagnostic output pin and enable output to the list of features listed in the eighth paragraph in the

DESCRIPTION.....	2
• Changed to data manual template to include table of contents and section numbers .....	2
• Added ADC, VDD6, to <i>Typical Application Diagram</i> .....	3
• Changed PGND type from input to ground in <i>PIN FUNCTIONS</i> table.....	27
• Changed POS numbers in <i>ABSOLUTE MAXIMUM RATINGS</i> table for adjustments .....	29
• Changed POS numbers in <i>ABSOLUTE MAXIMUM RATINGS</i> table for adjustments .....	29
• Added Charge-pump overdrive voltage to the <i>ABSOLUTE MAXIMUM RATINGS</i> table .....	29
• Deleted DMUXO from Logic I/O voltage list (M1.15) in the <i>ABSOLUTE MAXIMUM RATINGS</i> table .....	29
• Deleted T <sub>J</sub> min value of –40 from <i>ABSOLUTE MAXIMUM RATINGS</i> table .....	29
• Changed unit for CDM on corner pins (750) from kV to V in the <i>ABSOLUTE MAXIMUM RATINGS</i> table.....	29
• Deleted T <sub>J</sub> min value of –40 from <i>ABSOLUTE MAXIMUM RATINGS</i> table .....	30
• Deleted VDDIO internal pullup diode note from the <i>RECOMMENDED OPERATING CONDITIONS</i> table.....	30
• Added values to the current consumption parameter in the <i>RECOMMENDED OPERATING CONDITIONS</i> table ...	30
• Changed condition statement for the <i>ELECTRICAL CHARACTERISTICS</i> table by adding T <sub>A</sub> over junction temperature with up to 150°C .....	32
• Added VDD6 <sub>ripple</sub> parameter to the <i>ELECTRICAL CHARACTERISTICS</i> table .....	32
• Added VDD6 output voltage to I <sub>VDD6</sub> parameter (A1.2) in the <i>ELECTRICAL CHARACTERISTICS</i> table .....	32
• Changed example to V <sub>dropout6</sub> (A1.3) test condition in the <i>ELECTRICAL CHARACTERISTICS</i> table .....	32
• Changed I <sub>VDD6_limit</sub> parameter description from current-limit to peak current in the <i>ELECTRICAL CHARACTERISTICS</i> table.....	32
• Changed A1.5 from F <sub>sw_VDD6</sub> , switching frequency to f <sub>clk_VDD6</sub> , clock frequency, added note, and deleted test condition from the <i>ELECTRICAL CHARACTERISTICS</i> table. Also added test condition .....	32
• Changed test condition for DC <sub>VDD6</sub> parameter (A1.6) from VBATP > 7 V to 0 <I <sub>VDD6</sub> < 1.3 A in the <i>ELECTRICAL CHARACTERISTICS</i> table.....	32
• Added Hysteresis parameter, min and max values to T <sub>prot_VDD6</sub> (A1.7) in the <i>ELECTRICAL CHARACTERISTICS</i> table. Changed test condition from <i>Global shutdown</i> to <i>Protection of VDD6, shared with VDD3/5 thermal protection</i> . for both T <sub>prot_VDD6</sub> parameters.....	32
• Added Hysteresis parameter, min and max values to T <sub>prot_VDD5</sub> (2.13) in the <i>ELECTRICAL CHARACTERISTICS</i> table. Changed test condition from <i>VDD5 switch-off</i> to <i>Protection of VDD5.In case of detected over-temperature, only VDD5 will be switched-off</i> for both T <sub>prot_VDD5</sub> parameters .....	32
• Added VDD3/5 end-value to test condition for the dVDD35/dt parameter (3.11) in the <i>ELECTRICAL CHARACTERISTICS</i> table.....	33
• Added Hysteresis parameter, min and max values to T <sub>prot_VDD3/5</sub> (3.13) in the <i>ELECTRICAL CHARACTERISTICS</i> table. Changed test condition from <i>Global shutdown</i> to <i>Protection of VDD3/5, treated as global thermal shutdown (shutdown for all regulators)</i> for both T <sub>prot_VDD3/5</sub> parameters .....	33
• Added test condition to the dVDD1/dt parameter (A4.14) in the <i>ELECTRICAL CHARACTERISTICS</i> table .....	34
• Added VSOUT1 text to test condition for VSOUT1 parameter (5.1) in the <i>ELECTRICAL CHARACTERISTICS</i> table .....	34
• Changed MVVSOUT1 min and max values from –15 and 15 to –35 and 35 in the <i>ELECTRICAL CHARACTERISTICS</i> table.....	34
• Added min and max values for the Threshold for tracking/non-tracking parameter in the <i>ELECTRICAL CHARACTERISTICS</i> table.....	34
• Added Hysteresis parameter, min and max values to T <sub>prot_VSOUT1</sub> (5.13) in the <i>ELECTRICAL CHARACTERISTICS</i> table. Changed test condition from <i>VSOUT1 switch-off</i> to <i>Protection of Sensor Supply. Only VSOUT1 switch-off</i> for both T <sub>prot_VSOUT1</sub> parameters.....	34
• Changed min and max values for VBATP_OV <sub>rise</sub> parameter from 29.5 and 32.5 to 34.7 and 36.7 (respectively) in the <i>ELECTRICAL CHARACTERISTICS</i> table. Also added test condition.....	34
• Deleted VBATP_OV <sub>hys</sub> (POS 6.6) from the <i>ELECTRICAL CHARACTERISTICS</i> table .....	34
• Changed min and max values for VBATP_OV <sub>fall</sub> parameter from 29 and 32 to 34.4 and 36.3 (respectively) in the <i>ELECTRICAL CHARACTERISTICS</i> table. Also added test condition .....	34
• Added Hysteresis parameter, min and max values to VDD5_UV (6.8) in the <i>ELECTRICAL CHARACTERISTICS</i> table. ....	34
• Changed max value for VDD5_OV from 5.5 to 5.45 in the <i>ELECTRICAL CHARACTERISTICS</i> table.....	34
• Added Hysteresis parameter, min and max values to VDD5_OV (6.10) in the <i>ELECTRICAL CHARACTERISTICS</i> table. ....	34
• Changed min value for VDD3/5_UV with test condition of 3.3-V setting (undervoltage) from 2.97 to 3 in the <i>ELECTRICAL CHARACTERISTICS</i> table .....	35
• Changed max value for VDD3/5_UV with test condition of 5-V setting (undervoltage) from 4.8 to 4.85 in the <i>ELECTRICAL CHARACTERISTICS</i> table .....	35
• Added Hysteresis parameter for 3.3 and 5 V settings, min and max values to VDD3/5_UV (6.12) in the	

<i>ELECTRICAL CHARACTERISTICS</i> table. ....	<a href="#">35</a>
• Changed max value for VDD3/5_OV with test condition of 3.3-V setting from 3.63 to 3.6 in the <i>ELECTRICAL CHARACTERISTICS</i> table.....	<a href="#">35</a>
• Added Hysteresis parameter for 3.3 and 5 V settings, min and max values to VDD3/5_OV (6.14) in the <i>ELECTRICAL CHARACTERISTICS</i> table. ....	<a href="#">35</a>
• Added Hysteresis parameter, min and max values to VDD1_UV (6.16) in the <i>ELECTRICAL CHARACTERISTICS</i> table. Changed test condition from <i>Sensed on VDD1_SENSE pin</i> to <i>Sensed on VDD1_SENSE pin. Relative thresholds are with respect to nominal 800-mV VDD1SENSE (Pos 4.2)</i> for both VDD1_UV parameters .....	<a href="#">35</a>
• Added Hysteresis parameter, min and max values to VDD1_OV (6.17) in the <i>ELECTRICAL CHARACTERISTICS</i> table. Changed test condition from <i>Sensed on VDD1_SENSE pin</i> to <i>Sensed on VDD1_SENSE pin. Relative thresholds are with respect to nominal 800-mV VDD1SENSE (Pos 4.2)</i> for both VDD1_OV parameters .....	<a href="#">35</a>
• Added Hysteresis parameter, min and max values to VSOUT1_UV (6.19) in the <i>ELECTRICAL CHARACTERISTICS</i> table. Changed test condition from <i>Sensed on VSFB1 pin</i> to <i>Sensed on VSFB1 pin. Relative thresholds are:</i> for both VSOUT1_UV parameters .....	<a href="#">35</a>
• Added Hysteresis parameter, min and max values to VSOUT1_UV (6.20) in the <i>ELECTRICAL CHARACTERISTICS</i> table. Changed test condition from <i>Sensed on VSFB1 pin</i> to <i>Sensed on VSFB1 pin. Relative thresholds are:</i> for both VSOUT1_UV parameters .....	<a href="#">35</a>
• Added Hysteresis parameter, min and max values to VDD6_UV (6.22) in the <i>ELECTRICAL CHARACTERISTICS</i> table. Also added test condition for both VDD6_UV parameters .....	<a href="#">35</a>
• Added Hysteresis parameter, min and max values to VDD6_OV (6.23) in the <i>ELECTRICAL CHARACTERISTICS</i> table. Also added test condition for both VDD6_OV parameters .....	<a href="#">35</a>
• Added test condition to the I_IGN parameter in the the <i>ELECTRICAL CHARACTERISTICS</i> table(7.4).....	<a href="#">35</a>
• Changed I_CAN parameter (7.7) to I_CANWU and added test condition to the <i>ELECTRICAL CHARACTERISTICS</i> table.....	<a href="#">35</a>
• Changed I_CAN_rev (7.8) max value from 1 to –1 in the <i>ELECTRICAL CHARACTERISTICS</i> table .....	<a href="#">35</a>
• Added test condition for I <sub>CP</sub> (8.2) in the <i>ELECTRICAL CHARACTERISTICS</i> table .....	<a href="#">35</a>
• Added min and max values for f <sub>CP</sub> (8.3) in the <i>ELECTRICAL CHARACTERISTICS</i> table.....	<a href="#">36</a>
• Deleted min value of 11 for the R <sub>dson_ENDRV_NRES</sub> (9.2a) parameter in the <i>ELECTRICAL CHARACTERISTICS</i> table .....	<a href="#">36</a>
• Added input and logic 1 to the V <sub>ENDRV_NRES_TH</sub> parameter (9.5) description in the <i>ELECTRICAL CHARACTERISTICS</i> table.....	<a href="#">36</a>
• Deleted max value from 500 to 450 for the V <sub>ENDRV_NRES_TH</sub> (9.5) parameter in the <i>ELECTRICAL CHARACTERISTICS</i> table .....	<a href="#">36</a>
• Added note reference and test condition to the V <sub>DIGIN_LOW</sub> parameter (10.2) in the <i>ELECTRICAL CHARACTERISTICS</i> table .....	<a href="#">36</a>
• Added note reference and test condition to the V <sub>DIGIN_HYST</sub> parameter (10.3) in the <i>ELECTRICAL CHARACTERISTICS</i> table. Also added parameter name .....	<a href="#">36</a>
• Changed 10.4 from empty to the R <sub>DIAGOUT_AMUX</sub> parameter to the <i>ELECTRICAL CHARACTERISTICS</i> table .....	<a href="#">36</a>
• Added pin note to the V <sub>DIGOUT_HIGH</sub> parameter (10.5) in the <i>ELECTRICAL CHARACTERISTICS</i> table .....	<a href="#">36</a>
• Added pin note to the V <sub>DIGOUT_LOW</sub> parameter (10.6) in the <i>ELECTRICAL CHARACTERISTICS</i> table .....	<a href="#">36</a>
• Added min and max values for t <sub>RSTEXT(0kΩ)</sub> (9.4a) in the <i>ELECTRICAL CHARACTERISTICS</i> table .....	<a href="#">36</a>
• Added t <sub>WD_pulse</sub> parameter to the <i>ELECTRICAL CHARACTERISTICS</i> table .....	<a href="#">37</a>
• Added <i>for MCU error signal monitor</i> to the t <sub>ERROR_WDL_degltch</sub> parameter (12.1) in the <i>ELECTRICAL CHARACTERISTICS</i> table .....	<a href="#">37</a>
• Changed max value for the t <sub>ERROR_WDL_degltch</sub> parameter (12.1) from 15.75 to 16.25 in the <i>ELECTRICAL CHARACTERISTICS</i> table.....	<a href="#">37</a>
• Added two test conditions to the f <sub>SPi</sub> parameter (13.1) and removed the single max value of 8 to replace it with the max value for each condition in the <i>ELECTRICAL CHARACTERISTICS</i> table.....	<a href="#">37</a>
• Added two test conditions to the t <sub>SPi</sub> parameter (13.2) and removed the single min value of 125 to replace it with the min value for each condition in the <i>ELECTRICAL CHARACTERISTICS</i> table.....	<a href="#">37</a>
• Changed max value for t <sub>susl</sub> (13.7) to min value in the <i>ELECTRICAL CHARACTERISTICS</i> table. Also changed parameter description from rising edge to falling edge of SCLK.....	<a href="#">37</a>
• Changed min value from 250 to 788 for the t <sub>plcs</sub> parameter (13.10) in the <i>ELECTRICAL CHARACTERISTICS</i> table. Also added NCS high text to parameter description .....	<a href="#">37</a>
• Added test condition to the f <sub>Sysclk</sub> parameter (11.1) in the <i>ELECTRICAL CHARACTERISTICS</i> table .....	<a href="#">37</a>
• Added SDO transition from tri-state to t <sub>d1</sub> parameter (13.6) description in the <i>ELECTRICAL CHARACTERISTICS</i> table .....	<a href="#">37</a>
• Changed max value of t <sub>d1</sub> from 30 to 53.3 in the <i>ELECTRICAL CHARACTERISTICS</i> table .....	<a href="#">37</a>

- Changed max value of  $t_{d2}$  from 30 to 85.7 in the *ELECTRICAL CHARACTERISTICS* table. parameter description from falling edge to rising edge of SCLK ..... [37](#)
- Changed  $t_{tri}$  parameter (13.11) description from Hi-Z state to tristate in the *ELECTRICAL CHARACTERISTICS* table ..... [37](#)
- Changed max value of  $t_{tri}$  (13.11) from 15 to 25 in the *ELECTRICAL CHARACTERISTICS* table ..... [37](#)
- Added  $t_{d2}$  to right side of *SPI Timing Parameters* diagram ..... [37](#)
- Added the *SPI SDO Buffer Source/Sink Current* graph after the *ELECTRICAL CHARACTERISTICS* table..... [38](#)
- Changed block diagram ..... [39](#)
- Added condition for when the N-channel MOSFET turns on to the second paragraph in the *VDD6 Buck Switch Mode Power Supply* section ..... [40](#)
- Deleted clearing out of SAFETY\_STAT from re-enable VDD5 paragraph and changed SENS\_CTRL bit from 4 to D4 in the *VDD5 Linear Regulator* section..... [40](#)
- Added the default VDD1 paragraph to the end of the *VDD1 Linear Regulator* section..... [42](#)
- Added sentence to the first paragraph in the *VSOUT1 Linear Regulator* section describing what occurs after completion of the VDDx ramp-up ..... [42](#)
- Changed tracking offset from  $\pm 15$  to  $\pm 35$  in the *VSOUT1 Linear Regulator* section ..... [42](#)
- Added SPI command setting to the seventh paragraph in the *VSOUT1 Linear Regulator* section ..... [42](#)
- Added DIAGNOSTIC state text to the *Wake-Up* section..... [43](#)
- Changed second paragraph in the *Wake-Up* section: changed edge-sensitive to level-sensitive and pulse duration to deglitch time. .... [43](#)
- Added *during a power-up event* to the *Reset Extension* section and removed VDD1 from the description ..... [44](#)
- Deleted open-connect and RESET state sentence from the last paragraph in the *Reset Extension* section..... [44](#)
- Changed *Power-Up and Power-Down Behavior* image in the *Power-Up and Power-Down Behavior* section ..... [45](#)
- Added notes to the *IGN Power Latch and POST-RUN Reset* image in the *Power-Up and Power-Down Behavior* section ..... [46](#)
- Deleted reset driver from ENDRV bullet in the *Safety Functions and Diagnostics Overview* section ..... [47](#)
- Added the *Voltage Monitoring Overview* table and table reference to the *Voltage Monitor (VMON)* section..... [47](#)
- Added the *Internal Error Signals* table ..... [49](#)
- Deleted loss-of-power note and cleared-latched bullet from the clock failure list in the *Loss-of-Clock Monitor (LCMON)* section ..... [51](#)
- Added SPI register bit to the latched bullet in the clock failure list in the *Loss-of-Clock Monitor (LCMON)* section ... [51](#)
- Added ABIST case paragraphs following the *Analog BIST Run States* image ..... [52](#)
- Moved *Logic Built-In Self-Test (LBIST)* section from after DMUX tables and added initialized registers list ..... [53](#)
- Deleted VDD5 and VSOUT1 supplies from first paragraph of the *Junction Temperature Monitoring and Current Limiting* section ..... [54](#)
- Added VSOUT1 supplies paragraph to the *Junction Temperature Monitoring and Current Limiting* section ..... [54](#)
- Added ..... [54](#)
- Deleted STANDBY State text from the *Junction Temperature Monitoring and Current Limiting* section and changed to regulated supplies. Also added ENDRV pin ..... [54](#)
- Changed third paragraph of the *Junction Temperature Monitoring and Current Limiting* section to include NRES asserted low and VDD5 reenable ..... [54](#)
- Added *Thermal and Overcurrent Protect Overview* table and table reference to the *Junction Temperature Monitoring and Current Limiting* section..... [55](#)
- Added analog and digital signals and notes to the *Diagnostic Output Pin DIAG\_OUT* image in the *Diagnostic Output Pin DIAG\_OUT* section ..... [56](#)
- Added added disabled state description for the DIAG\_OUT pin in the last paragraph of the *Diagnostic Output Pin DIAG\_OUT* section ..... [56](#)
- Added *accuracy* and corresponding table note to the voltage range column in the *Analog MUX Selection* table ..... [57](#)
- Added  $\pm$  percentage to the divide ratio values (except for MAIN\_BG and VMON\_BG) the *Analog MUX Selection* table ..... [57](#)
- Changed the DIAG\_MUX\_SEL column and header in the *Analog MUX Selection* table ..... [57](#)
- Added the max output resistance column to the *Analog MUX Selection* table ..... [57](#)
- Changed VSFB1 divide ratio from 1 to 4 in the *Analog MUX Selection* Table ..... [57](#)
- Added the voltage/signal name for signal number A.7 from BG1 to MAIN\_BG in the *Analog MUX Selection* table .. [57](#)
- Added additional text and note to further explain the *Analog MUX Selection* Table ..... [57](#)
- Added second paragraph to the *Digital MUX (DMUX)* section..... [57](#)
- Added diagnostic check text, *Diagnostic MUX Output state (by MUX\_OUT bit)*, and *MUX interconnect check* section after DMUX tables ..... [60](#)
- Changed the *Watchdog Enable Function* image in the *WDT Fail Counter, WDT Status, and WDT Fail Event* section ..... [61](#)

- Added watchdog fail counter text after the *Watchdog Status for Fail Counter Value Range* table..... [61](#)
- Changed trigger events paragraph (third) in the *WDTI Configuration with External Trigger Input (Default Mode)* section ..... [63](#)
- Added SPI register names and DIAGNOSTIC state to the open and close window programming sentence in the *WDTI Configuration with External Trigger Input (Default Mode)* section ..... [64](#)
- Added the WDTI window sequencing and SPI SW\_LOCK paragraphs in the *WDTI Configuration with External Trigger Input (Default Mode)* section ..... [64](#)
- Added the WDTI rising edge paragraph in the *WDTI Configuration with External Trigger Input (Default Mode)* section and added  $t_{WD\_pulse}$  filter time paragraph ..... [64](#)
- Added image to the *WDTI Configuration with External Trigger Input (Default Mode)* section ..... [65](#)
- Added image to the *WDTI Configuration with External Trigger Input (Default Mode)* section ..... [66](#)
- Deleted ASIC reference in the first paragraph of the *Watchdog Question /and Answer Configuration Through SPI* section ..... [67](#)
- Added *starts a new watchdog token-response sequence run* to the no-response event description in paragraph four of the *Watchdog Question /and Answer Configuration Through SPI* section ..... [67](#)
- Added 4-bit word bullet to the *Watchdog Token Request* definition list in the *Watchdog-Timer-Related SPI Event Definitions* section ..... [67](#)
- Added 32-bit word bullet to the *Watchdog Token Timer Request* definition list in the *Watchdog-Timer-Related SPI Event Definitions* section ..... [68](#)
- Added *Watchdog Token-Response Sequence Run* section to replace the *Watchdog Timer Configuration for Question and Answer Configuration* section..... [68](#)
- Changed the *WDT Token and Response Sequence Run* image in the *Watchdog Token-Response Sequence Run* section ..... [69](#)
- Added the 4-bit question paragraph to the *Watchdog Token Value Generation (or Watchdog Question Generation)* section ..... [69](#)
- Added the *Watchdog TOKEN Generation* image and following text in the *Watchdog Timer Configuration for Question and Answer Configuration* section..... [70](#)
- Added *Answer Comparison and Reference Answer* section ..... [72](#)
- Changed WDT answer column header names - switched response 0 and response 3, switched response 2 and response 1 in the *Set of 4-Bit WD Token Values and Corresponding 8-Bit Responses* table. Added token registerDevice Configuration Register Protection name and value to token column. .... [73](#)
- Added *Watchdog Token-Response Sequence Run and WDT\_STATUS Register Updates* section ..... [73](#)
- Added activation and deactivation paragraph in the *MCU Error Signal Monitor (MCU ESM)* section ..... [75](#)
- Added DIAGNOSTIC and ACTIVE state paragraph in the *MCU Error Signal Monitor (MCU ESM)* section..... [76](#)
- Added deglitched and synchronized paragraph in the *MCU Error Signal Monitor (MCU ESM)* section..... [76](#)
- Added ERROR/WDI pin implementation text in the *MCU Error Signal Monitor (MCU ESM)* section..... [76](#)
- Added the first paragraph in the *PWM Mode* section and added the detect and no detect statements..... [78](#)
- Added monitoring lists to the *PWM Mode* section ..... [78](#)
- Changed register setting text for the ERROR\_PIN\_FAIL bit from error-pin signaling failure to system clock detection to the *PWM Mode* section ..... [80](#)
- Added CFG\_CRC\_ERR flag text to the *Device Configuration Register Protection* section ..... [81](#)
- Changed CRC-8 polynomial from  $X^8 + X^7 + X^6 + X^4 + X^2 + 1$  to  $X^8 + X^2 + X^1 + 1$  in the *Device Configuration Register Protection* section ..... [81](#)
- Added 64-bit string text and protected registers list in the *Device Configuration Register Protection* section..... [81](#)
- Added *CRC Bus Structure* table in the *Device Configuration Register Protection* section ..... [82](#)
- Added CRC calculation text, image, and table in the *Device Configuration Register Protection* section ..... [82](#)
- Added EEPROM CRC check and list of steps in the *Device Configuration Register Protection* section..... [83](#)
- Changed the *Reset and Enable Circuit* image in the *Enable and Reset Driver Circuit* section..... [84](#)
- Added ENDRV pulled low paragraph to the *Enable and Reset Driver Circuit* section ..... [84](#)
- Changed timing-response diagram description from RESET condition to any VDDx UV or OV condition in the *Enable and Reset Driver Circuit* section ..... [85](#)
- Added RESET condition image in the *Enable and Reset Driver Circuit* section and replaced it with the any VDDx UV or OV condition image ..... [85](#)
- Changed *Device Controller State Diagram* image ..... [86](#)
- Added *Internal NPOR (power-on reset)* bullet item in the *STANDBY STATE* section ..... [87](#)
- Changed *IGN and CANWU driven low* bullet item to deglitched IGN, IGN\_PWRL, and CANWU\_L with values in the *STANDBY STATE* section..... [87](#)
- Added device error count text to the SAFE state bullet in the *RESET STATE* list ..... [87](#)
- Deleted the ACTIVE state bullet in the *RESET STATE* list..... [87](#)
- Added VDD5 sub-bullet in the *RESET STATE* list..... [87](#)

- Added watchdog fail counter text to the watchdog reset sub-bullet in the *RESET STATE* list ..... [87](#)
- Added ramping up sub-bullet to the first item in the *RESET STATE* list..... [88](#)
- Added RESET State transition paragraph to the *RESET STATE* list ..... [88](#)
- Added NRES pulled up to the *Enters RESET state* bullet in the *DIAGNOSTIC STATE* list ..... [88](#)
- Added VSOUT1, watchdog and ERROR/WDI, watchdog failure counter, and ENDRV pin bullets in the *DIAGNOSTIC STATE* list ..... [88](#)
- Added DIAG\_EXIT\_MASK and DIAG\_EXIT text to the end of the *DIAGNOSTIC STATE* list..... [88](#)
- Changed two bullets in the ACTIVE STATE list and added three additional bullets ..... [89](#)
- Added uncontrolled transition sub-bullet to the enters DIAGNOSTIC state bullet in the *SAFE STATE* list..... [90](#)
- Added ACTIVE state read-back error, stays in Safe state, NRES, and VDDx bullets in the *SAFE STATE* list ..... [90](#)
- Added *STATE TRANSITION PRIORITIES* section..... [91](#)
- Deleted *Enters from RESET, DIAGNOSTIC, or ACTIVE state after ABIST or LBIST failure* bullet from the SPI 4-pin list in the *SPI Interface* section..... [92](#)
- Changed speed from 10 to 6 Mbit/s in the *SPI Interface* section ..... [92](#)
- Added minimum time sentence to paragraph after the *SPI Command Transfer Phase* table ..... [92](#)
- Deleted paragraph describing the possibility of mixing two access modes in the *SPI Data-Transfer Phase* section.. [93](#)
- Added minimum time sentence to paragraph after the *SPI Data-Transfer Phase* table ..... [93](#)
- Added status bit paragraph and note after the *Device Status Flag Byte Response* table..... [93](#)
- Added 8-bit hex column to the *SPI Command Table*..... [95](#)
- Changed D5 from 0 to 1 in the *DEV\_REV Register* table ..... [96](#)
- Changed D0 from 0 to 1 in the *DEV\_REV Register* table ..... [96](#)
- Changed D0 from 0 to 1 in the *DEV\_ID Register* table ..... [97](#)
- Changed reset value text to D[1] and D[0] descriptions in the *DEV\_STATE Register* table ..... [97](#)
- Changed D6 from MASK\_VDD\_OV and 1 to nMASK\_VDD\_UV\_OV and 0 in the *DEV\_CFG1 Register* table ..... [98](#)
- Added ground and no ground to the SEL\_VDD3/5 description for both 5 V and 3.3 V in the *DEV\_CFG1 Register* table ..... [98](#)
- Added value in RESET State text in the *DEV\_CFG1 Register* table..... [98](#)
- Added READ-ONLY the *DEV\_CFG1 Register* table ..... [98](#)
- Added after first start-up text to D[6] if VDD1 text in the *DEV\_CFG1 Register* table ..... [98](#)
- Switched the names of D5 and D4 in *DEV\_CFG2 Register* table ..... [99](#)
- Changed EN\_VDD3/5\_OT description by removing extra text after *set to 1* and adding two more bullets in the *DEV\_CFG2 Register* table ..... [99](#)
- Changed read/writable text for D[3:0] in the *DEV\_CFG2 Register* table ..... [99](#)
- Changed AVDD\_VMON\_ERR description from error status to power-good status in the *VMON\_STAT\_1 Register* table..... [100](#)
- Changed *set to 1* text of D[1] in the *VMON\_STAT\_1 Register* table from when error is detected to when voltage monitor < main band gap ..... [100](#)
- Changed *set to 1* text of D[0] in the *VMON\_STAT\_1 Register* table fro ..... [100](#)
- Changed m when error is detected to when voltage monitor > main band gap ..... [100](#)
- Changed name of D6 from VDD3\_ILIM to VDD3\_5\_ILIM in the *SAFETY\_STAT\_1 Register* table ..... [102](#)
- Added note to D[7] description in the *SAFETY\_STAT\_1 Register* table ..... [102](#)
- Added EEPROM bullet to D[5] description in the *SAFETY\_STAT\_2 Register* table ..... [103](#)
- Added DIAGNOSTIC and ACTIVE State text to D[2:0] default bullet in the *SAFETY\_STAT\_2 Register* table..... [103](#)
- Added cleared to text to the D[5] description in the *SAFETY\_STAT\_3 Register* table..... [104](#)
- Changed D7 and D6 from 1 to 0 in the *SAFETY\_STAT\_4 Register* table ..... [105](#)
- Changed name of D0 from TRIM\_ERR to TRIM\_ERR\_VMON in the *SAFETY\_STAT\_4 Register* table..... [105](#)
- Added cleared to bullet and note to D[7:6] description in the *SAFETY\_STAT\_4 Register* table..... [105](#)
- Changed *set to* text to include error-signal monitoring in the D[3] description in the *SAFETY\_STAT\_4 Register* table ..... [105](#)
- Added ERROR\_PIN\_FAIL text to D[3] cleared description in the *SAFETY\_STAT\_4 Register* table..... [105](#)
- Added Watchdog Fail Counter text to the D[2] *set to* and *cleared to* descriptions in the *SAFETY\_STAT\_4 Register* table..... [105](#)
- Deleted SPI read access from D[1]*cleared to* description in the *SAFETY\_STAT\_4 Register* table ..... [105](#)
- Changed SPI read access to NPOR in the D[0]*cleared to* description in the *SAFETY\_STAT\_4 Register* table ..... [105](#)
- Changed D4 from 1 to 0 and D1 and D0 from 0 to 1 in the *SAFETY\_STAT\_5 Register* table ..... [106](#)
- Changed threshold from max to min for the 0000 setting description in the *SAFETY\_ERR\_CFG Register* table ... [106](#)
- Changed D7 and D6 from 1 to 0 in the *SAFETY\_BIST\_CTRL Register* table ..... [107](#)
- Changed D3 from LOCLK\_EN to RSV in the *SAFETY\_BIST\_CTRL Register* table ..... [107](#)
- Added ACTIVE state bullet to D[7:6] description in the *SAFETY\_BIST\_CTRL Register* table..... [107](#)
- Added DIAGNOSTIC and ACTIVE states to D[5] description in the *SAFETY\_BIST\_CTRL Register* table ..... [107](#)

• Changed D4 from NO_WRST to RSV in the <i>SAFETY_CHECK_CTRL Register</i> table .....	<a href="#">108</a>
• Added DEV_CFG2 and DEV_CFG1 to D[7] list of protected registers in the <i>SAFETY_CHECK_CTRL Register</i> table .....	<a href="#">108</a>
• Added device state, ENDRV and NRES to D[6] description in the <i>SAFETY_CHECK_CTRL Register</i> table .....	<a href="#">108</a>
• Changed D[3] from not read/writable to read/writable in the <i>SAFETY_CHECK_CTRL Register</i> table .....	<a href="#">108</a>
• Added ERROR_PIN_FAIL sub-bullet to D[2] description in the <i>SAFETY_CHECK_CTRL Register</i> table .....	<a href="#">108</a>
• Changed D7 from 0 to 1 in the <i>SAFETY_FUNC_CFG Register</i> table.....	<a href="#">109</a>
• Changed D2 from RSV to DIS_NRES_MON in the <i>SAFETY_FUNC_CFG Register</i> table .....	<a href="#">109</a>
• Changed D0 from 0 to X in the <i>SAFETY_FUNC_CFG Register</i> table .....	<a href="#">109</a>
• Added SAFE state-time sub-bullet to the D[7] description in the <i>SAFETY_FUNC_CFG Register</i> table.....	<a href="#">109</a>
• Changed D[6] description from error-pin to Error-Signal Monitor in the <i>SAFETY_FUNC_CFG Register</i> table .....	<a href="#">109</a>
• Deleted watchdog pin from the D[6] description in the <i>SAFETY_FUNC_CFG Register</i> table .....	<a href="#">109</a>
• Added note text to the D[4] description in the <i>SAFETY_FUNC_CFG Register</i> table.....	<a href="#">109</a>
• Added STANDBY state text to the D[4] description in the <i>SAFETY_FUNC_CFG Register</i> table .....	<a href="#">109</a>
• Deleted <i>enabling/disabling the watchdog</i> bullet from the D[3] description in the <i>SAFETY_FUNC_CFG Register</i> table .....	<a href="#">109</a>
• Added bullets to the D[2] description in the <i>SAFETY_FUNC_CFG Register</i> table .....	<a href="#">109</a>
• Changed D[1] from not read/writable to read/writable in the <i>SAFETY_FUNC_CFG Register</i> table.....	<a href="#">109</a>
• Added READ-ONLY bullet, RESET STATE sub-bullet, and connected and not-connected text to the D[0] description in the <i>SAFETY_FUNC_CFG Register</i> table.....	<a href="#">109</a>
• Added ERROR/WDI and SAFE state text to the D[5] <i>set to</i> description in the <i>SAFETY_ERR_STAT Register</i> table .....	<a href="#">110</a>
• Added WD_RST_EN text to D[4] <i>set to</i> description in the <i>SAFETY_ERR_STAT Register</i> table.....	<a href="#">110</a>
• Added watchdog fail counter text to D[4] <i>cleared to</i> description in the <i>SAFETY_ERR_STAT Register</i> table.....	<a href="#">110</a>
• Added equation and oscillator text to the <i>SAFETY_ERR_PWM_H Register</i> table description .....	<a href="#">110</a>
• Changed D4, D2, and D0 from 0 to 1 in the <i>SAFETY_ERR_PWM_L Register</i> description .....	<a href="#">111</a>
• Added equations and oscillator text to the <i>SAFETY_ERR_PWM_H Register</i> table description .....	<a href="#">111</a>
• Changed D4 from 1 to 0 in the <i>SAFETY_PWD_THR_CFG Register</i> table.....	<a href="#">111</a>
• Changed _THR to PWD names for D3:D0 in the <i>SAFETY_PWD_THR_CFG Register</i> table .....	<a href="#">111</a>
• Changed D7, D5, and D3 from 1 to 0 in the <i>SAFETY_CFG_CRC Register</i> table .....	<a href="#">111</a>
• Changed D4 from 0 to 1 in the <i>SAFETY_CFG_CRC Register</i> table .....	<a href="#">111</a>
• Changed D[7] description from high-impedance to tri-stated in the <i>DIAG_CFG_CTRL Register</i> table .....	<a href="#">112</a>
• Added SDO diagnostics from D[1:0] description to the D[6] description in the <i>DIAG_CFG_CTRL Register</i> table ...	<a href="#">112</a>
• Changed D2 from 1 to 0 in the <i>WDT_TOKEN_FDBCK Register</i> table .....	<a href="#">113</a>
• Added bullets to the D[7:4] description in the <i>WDT_TOKEN_FDBCK Register</i> table .....	<a href="#">113</a>
• Added new TOKEN seed bullet and sub-bullets to the D[3:0] description in the <i>WDT_TOKEN_FDBCK Register</i> table .....	<a href="#">113</a>
• Changed D6:D0 from 0 to 1 in the <i>WDT_WIN1_CFG Register</i> table .....	<a href="#">113</a>
• Changed D4:D3 from 0 to 1 in the <i>WDT_WIN2_CFG Register</i> table.....	<a href="#">113</a>
• Changed D7 from 0 to 1 in the <i>WDT_TOKEN_VALUE Register</i> table .....	<a href="#">114</a>
• Changed MCU sub-bullet from D[7] description to replace Q&A sub-bullet in the D[3:0] description of the <i>WDT_TOKEN_VALUE Register</i> table .....	<a href="#">114</a>
• Changed D7:D6 from 0 to 1 in the <i>WDT_STATUS Register</i> table .....	<a href="#">114</a>
• Changed D7:DF from RSV to WD_WRONG_CFG in the <i>WDT_STATUS Register</i> table .....	<a href="#">114</a>
• Changed <i>set to</i> text of the D[5] description in the <i>WDT_STATUS Register</i> table .....	<a href="#">114</a>
• Changed D[4] note from recommendation to clear bit to remains set to 1 in the <i>SENS_CTRL Register</i> table .....	<a href="#">115</a>
• Changed <i>Typical Application Diagram</i> image .....	<a href="#">117</a>

Changes from Original (July 2016) to Revision A	Page
• Changed current limit for 6-V pre-regulator from 1.5 A to 1.3 A in the <i>FEATURES</i> list .....	1
• Added current limit to the 5-V (CAN) bullet in the <i>FEATURES</i> list .....	1
• Added current limit to the 3.3-V or 5-V MCU I/O Voltage bullet in the <i>FEATURES</i> list .....	1
• Deleted reverse battery protection bullet from the <i>FEATURES</i> list .....	1
• Changed current limit from 300 mA to 100 mA in the sensor supply bullet in the <i>FEATURES</i> list .....	1
• Deleted wake-up and enable circuit bullets from the <i>FEATURES</i> list .....	1
• Added <i>Independent</i> to voltage monitoring bullet in the <i>FEATURES</i> list.....	1
• Added <i>Independent Bandgap Reference</i> bullet to the <i>FEATURES</i> list.....	1
• Added <i>Diagnostic Output Pin</i> bullet to the <i>FEATURES</i> list .....	1
• Added Safting-Pin and IGNITION Pin bullets to the <i>FEATURES</i> list .....	1
• Changed document status from <i>Product Preview</i> to <i>Production Data</i> .....	1
• Added CAN Transceiver sentence to the second paragraph in the <i>DESCRIPTION</i> .....	2
• Changed adjustable core voltage range from 0.8 and 2.6 V to 0.8 and 3.3 V in the <i>DESCRIPTION</i> .....	2
• Added diagnostic output pin and enable output to the list of features listed in the eighth paragraph in the <i>DESCRIPTION</i> .....	2
• Changed to data manual template to include table of contents and section numbers .....	2
• Added ADC, VDD6, to <i>Typical Application Diagram</i> .....	3
• Changed PGND type from input to ground in <i>PIN FUNCTIONS</i> table.....	27
• Changed POS numbers in <i>ABSOLUTE MAXIMUM RATINGS</i> table for adjustments .....	29
• Changed POS numbers in <i>ABSOLUTE MAXIMUM RATINGS</i> table for adjustments .....	29
• Added Charge-pump overdrive voltage to the <i>ABSOLUTE MAXIMUM RATINGS</i> table .....	29
• Deleted DMUXO from Logic I/O voltage list (M1.15) in the <i>ABSOLUTE MAXIMUM RATINGS</i> table .....	29
• Deleted T <sub>J</sub> min value of –40 from <i>ABSOLUTE MAXIMUM RATINGS</i> table .....	29
• Changed unit for CDM on corner pins (750) from kV to V in the <i>ABSOLUTE MAXIMUM RATINGS</i> table.....	29
• Deleted T <sub>J</sub> min value of –40 from <i>ABSOLUTE MAXIMUM RATINGS</i> table .....	30
• Deleted VDDIO internal pullup diode note from the <i>RECOMMENDED OPERATING CONDITIONS</i> table.....	30
• Added values to the current consumption parameter in the <i>RECOMMENDED OPERATING CONDITIONS</i> table ...	30
• Changed condition statement for the <i>ELECTRICAL CHARACTERISTICS</i> table by adding T <sub>A</sub> over junction temperature with up to 150°C .....	32
• Added VDD6 <sub>ripple</sub> parameter to the <i>ELECTRICAL CHARACTERISTICS</i> table .....	32
• Added VDD6 output voltage to I <sub>VDD6</sub> parameter (A1.2) in the <i>ELECTRICAL CHARACTERISTICS</i> table .....	32
• Changed example to V <sub>dropout6</sub> (A1.3) test condition in the <i>ELECTRICAL CHARACTERISTICS</i> table .....	32
• Changed I <sub>VDD6_limit</sub> parameter description from current-limit to peak current in the <i>ELECTRICAL CHARACTERISTICS</i> table.....	32
• Changed A1.5 from F <sub>sw_VDD6</sub> , switching frequency to f <sub>clk_VDD6</sub> , clock frequency, added note, and deleted test condition from the <i>ELECTRICAL CHARACTERISTICS</i> table. Also added test condition .....	32
• Changed test condition for DC <sub>VDD6</sub> parameter (A1.6) from VBATP > 7 V to 0 <I <sub>VDD6</sub> < 1.3 A in the <i>ELECTRICAL CHARACTERISTICS</i> table.....	32
• Added Hysteresis parameter, min and max values to T <sub>prot_VDD6</sub> (A1.7) in the <i>ELECTRICAL CHARACTERISTICS</i> table. Changed test condition from <i>Global shutdown</i> to <i>Protection of VDD6, shared with VDD3/5 thermal protection</i> . for both T <sub>prot_VDD6</sub> parameters .....	32
• Added Hysteresis parameter, min and max values to T <sub>prot_VDD5</sub> (2.13) in the <i>ELECTRICAL CHARACTERISTICS</i> table. Changed test condition from <i>VDD5 switch-off</i> to <i>Protection of VDD5. In case of detected over-temperature, only VDD5 will be switched-off</i> for both T <sub>prot_VDD5</sub> parameters .....	32
• Added VDD3/5 end-value to test condition for the dVDD35/dt parameter (3.11) in the <i>ELECTRICAL CHARACTERISTICS</i> table.....	33
• Added Hysteresis parameter, min and max values to T <sub>prot_VDD3/5</sub> (3.13) in the <i>ELECTRICAL CHARACTERISTICS</i> table. Changed test condition from <i>Global shutdown</i> to <i>Protection of VDD3/5, treated as global thermal shutdown (shutdown for all regulators)</i> for both T <sub>prot_VDD3/5</sub> parameters .....	33
• Added test condition to the dVDD1/dt parameter (A4.14) in the <i>ELECTRICAL CHARACTERISTICS</i> table .....	34
• Added VSOUT1 text to test condition for VSOUT1 parameter (5.1) in the <i>ELECTRICAL CHARACTERISTICS</i> table .....	34
• Changed MVVSOUT1 min and max values from –15 and 15 to –35 and 35 in the <i>ELECTRICAL CHARACTERISTICS</i> table.....	34
• Added min and max values for the Threshold for tracking/non-tracking parameter in the <i>ELECTRICAL CHARACTERISTICS</i> table.....	34
• Added Hysteresis parameter, min and max values to T <sub>prot_VSOUT1</sub> (5.13) in the <i>ELECTRICAL CHARACTERISTICS</i> table. Changed test condition from <i>VSOUT1 switch-off</i> to <i>Protection of Sensor Supply</i> .	34

Only VSOUT1 switch-off for both Tprot <sub>VSOUT1</sub> parameters.....	<a href="#">34</a>
• Changed min and max values for VBATP_OV <sub>rise</sub> parameter from 29.5 and 32.5 to 34.7 and 36.7 (respectively) in the ELECTRICAL CHARACTERISTICS table. Also added test condition.....	<a href="#">34</a>
• Deleted VBATP_OV <sub>hys</sub> (POS 6.6) from the ELECTRICAL CHARACTERISTICS table .....	<a href="#">34</a>
• Changed min and max values for VBATP_OV <sub>fall</sub> parameter from 29 and 32 to 34.4 and 36.3 (respectively) in the ELECTRICAL CHARACTERISTICS table. Also added test condition .....	<a href="#">34</a>
• Added Hysteresis parameter, min and max values to VDD5_UV (6.8) in the ELECTRICAL CHARACTERISTICS table. ....	<a href="#">34</a>
• Changed max value for VDD5_OV from 5.5 to 5.45 in the ELECTRICAL CHARACTERISTICS table.....	<a href="#">34</a>
• Added Hysteresis parameter, min and max values to VDD5_OV (6.10) in the ELECTRICAL CHARACTERISTICS table. ....	<a href="#">34</a>
• Changed min value for VDD3/5_UV with test condition of 3.3-V setting (undervoltage) from 2.97 to 3 in the ELECTRICAL CHARACTERISTICS table .....	<a href="#">35</a>
• Changed max value for VDD3/5_UV with test condition of 5-V setting (undervoltage) from 4.8 to 4.85 in the ELECTRICAL CHARACTERISTICS table .....	<a href="#">35</a>
• Added Hysteresis parameter for 3.3 and 5 V settings, min and max values to VDD3/5_UV (6.12) in the ELECTRICAL CHARACTERISTICS table. ....	<a href="#">35</a>
• Changed max value for VDD3/5_OV with test condition of 3.3-V setting from 3.63 to 3.6 in the ELECTRICAL CHARACTERISTICS table.....	<a href="#">35</a>
• Added Hysteresis parameter for 3.3 and 5 V settings, min and max values to VDD3/5_OV (6.14) in the ELECTRICAL CHARACTERISTICS table. ....	<a href="#">35</a>
• Added Hysteresis parameter, min and max values to VDD1_UV (6.16) in the ELECTRICAL CHARACTERISTICS table. Changed test condition from Sensed on VDD1_SENSE pin to Sensed on VDD1_SENSE pin. Relative thresholds are with respect to nominal 800-mV VDD1SENSE (Pos 4.2) for both VDD1_UV parameters .....	<a href="#">35</a>
• Added Hysteresis parameter, min and max values to VDD1_OV (6.17) in the ELECTRICAL CHARACTERISTICS table. Changed test condition from Sensed on VDD1_SENSE pin to Sensed on VDD1_SENSE pin. Relative thresholds are with respect to nominal 800-mV VDD1SENSE (Pos 4.2) for both VDD1_OV parameters.....	<a href="#">35</a>
• Added Hysteresis parameter, min and max values to VSOUT1_UV (6.19) in the ELECTRICAL CHARACTERISTICS table. Changed test condition from Sensed on VSFB1 pin to Sensed on VSFB1 pin. Relative thresholds are: for both VSOUT1_UV parameters .....	<a href="#">35</a>
• Added Hysteresis parameter, min and max values to VSOUT1_OV (6.20) in the ELECTRICAL CHARACTERISTICS table. Changed test condition from Sensed on VSFB1 pin to Sensed on VSFB1 pin. Relative thresholds are: for both VSOUT1_OV parameters .....	<a href="#">35</a>
• Added Hysteresis parameter, min and max values to VDD6_UV (6.22) in the ELECTRICAL CHARACTERISTICS table. Also added test condition for both VDD6_UV parameters .....	<a href="#">35</a>
• Added Hysteresis parameter, min and max values to VDD6_OV (6.23) in the ELECTRICAL CHARACTERISTICS table. Also added test condition for both VDD6_OV parameters .....	<a href="#">35</a>
• Added test condition to the I <sub>IGN</sub> parameter in the the ELECTRICAL CHARACTERISTICS table(7.4).....	<a href="#">35</a>
• Changed I <sub>CAN</sub> parameter (7.7) to I <sub>CANWU</sub> and added test condition to the ELECTRICAL CHARACTERISTICS table.....	<a href="#">35</a>
• Changed I <sub>CAN_rev</sub> (7.8) max value from 1 to -1 in the ELECTRICAL CHARACTERISTICS table .....	<a href="#">35</a>
• Added test condition for I <sub>CP</sub> (8.2) in the ELECTRICAL CHARACTERISTICS table .....	<a href="#">35</a>
• Added min and max values for f <sub>CP</sub> (8.3) in the ELECTRICAL CHARACTERISTICS table.....	<a href="#">36</a>
• Deleted min value of 11 for the R <sub>dson_ENDRV_NRES</sub> (9.2a) parameter in the ELECTRICAL CHARACTERISTICS table .....	<a href="#">36</a>
• Added input and logic 1 to the V <sub>ENDRV_NRES_TH</sub> parameter (9.5) description in the ELECTRICAL CHARACTERISTICS table.....	<a href="#">36</a>
• Deleted max value from 500 to 450 for the V <sub>ENDRV_NRES_TH</sub> (9.5) parameter in the ELECTRICAL CHARACTERISTICS table .....	<a href="#">36</a>
• Added note reference and test condition to the V <sub>DIGIN_LOW</sub> parameter (10.2) in the ELECTRICAL CHARACTERISTICS table .....	<a href="#">36</a>
• Added note reference and test condition to the V <sub>DIGIN_HYST</sub> parameter (10.3) in the ELECTRICAL CHARACTERISTICS table. Also added parameter name.....	<a href="#">36</a>
• Changed 10.4 from empty to the R <sub>DIAGOUT_AMUX</sub> parameter to the ELECTRICAL CHARACTERISTICS table .....	<a href="#">36</a>
• Added pin note to the V <sub>DIGOUT_HIGH</sub> parameter (10.5) in the ELECTRICAL CHARACTERISTICS table .....	<a href="#">36</a>
• Added pin note to the V <sub>DIGOUT_LOW</sub> parameter (10.6) in the ELECTRICAL CHARACTERISTICS table .....	<a href="#">36</a>
• Added min and max values for t <sub>RSTEXT(0KΩ)</sub> (9.4a) in the ELECTRICAL CHARACTERISTICS table .....	<a href="#">36</a>
• Added t <sub>WD_pulse</sub> parameter to the ELECTRICAL CHARACTERISTICS table .....	<a href="#">37</a>

- Added for *MCU error signal monitor* to the  $t_{\text{ERROR\_WDL\_degitch}}$  parameter (12.1) in the *ELECTRICAL CHARACTERISTICS* table ..... [37](#)
- Changed max value for the  $t_{\text{ERROR\_WDL\_degitch}}$  parameter (12.1) from 15.75 to 16.25 in the *ELECTRICAL CHARACTERISTICS* table..... [37](#)
- Added two test conditions to the  $f_{\text{SPI}}$  parameter (13.1) and removed the single max value of 8 to replace it with the max value for each condition in the *ELECTRICAL CHARACTERISTICS* table..... [37](#)
- Added two test conditions to the  $t_{\text{SPI}}$  parameter (13.2) and removed the single min value of 125 to replace it with the min value for each condition in the *ELECTRICAL CHARACTERISTICS* table..... [37](#)
- Changed max value for  $t_{\text{suSI}}$ (13.7) to min value in the *ELECTRICAL CHARACTERISTICS* table. Also changed parameter description from rising edge to falling edge of SCLK..... [37](#)
- Changed min value from 250 to 788 for the  $t_{\text{hlcs}}$  parameter (13.10) in the *ELECTRICAL CHARACTERISTICS* table. Also added NCS high text to parameter description ..... [37](#)
- Added test condition to the  $f_{\text{Sysclk}}$  parameter (11.1) in the *ELECTRICAL CHARACTERISTICS* table ..... [37](#)
- Added SDO transition from tri-state to  $t_{\text{d1}}$  parameter (13.6) description in the *ELECTRICAL CHARACTERISTICS* table ..... [37](#)
- Changed max value of  $t_{\text{d1}}$  from 30 to 53.3 in the *ELECTRICAL CHARACTERISTICS* table ..... [37](#)
- Changed max value of  $t_{\text{d2}}$  from 30 to 85.7 in the *ELECTRICAL CHARACTERISTICS* table. parameter description from falling edge to rising edge of SCLK..... [37](#)
- Changed  $t_{\text{tri}}$  parameter (13.11) description from Hi-Z state to tristate in the *ELECTRICAL CHARACTERISTICS* table ..... [37](#)
- Changed max value of  $t_{\text{tri}}$  (13.11) from 15 to 25 in the *ELECTRICAL CHARACTERISTICS* table ..... [37](#)
- Added  $t_{\text{d2}}$  to right side of *SPI Timing Parameters* diagram ..... [37](#)
- Added the *SPI SDO Buffer Source/Sink Current* graph after the *ELECTRICAL CHARACTERISTICS* table..... [38](#)
- Changed block diagram ..... [39](#)
- Added condition for when the N-channel MOSFET turns on to the second paragraph in the *VDD6 Buck Switch Mode Power Supply* section ..... [40](#)
- Deleted clearing out of SAFETY\_STAT from re-enable VDD5 paragraph and changed SENS\_CTRL bit from 4 to D4 in the *VDD5 Linear Regulator* section..... [40](#)
- Added the default VDD1 paragraph to the end of the *VDD1 Linear Regulator* section..... [42](#)
- Added sentence to the first paragraph in the *VSOUT1 Linear Regulator* section describing what occurs after completion of the VDDx ramp-up ..... [42](#)
- Changed tracking offset from  $\pm 15$  to  $\pm 35$  in the *VSOUT1 Linear Regulator* section ..... [42](#)
- Added SPI command setting to the seventh paragraph in the *VSOUT1 Linear Regulator* section ..... [42](#)
- Added DIAGNOSTIC state text to the *Wake-Up* section..... [43](#)
- Changed second paragraph in the *Wake-Up* section: changed edge-sensitive to level-sensitive and pulse duration to degitch time. .... [43](#)
- Added *during a power-up event* to the *Reset Extension* section and removed VDD1 from the description ..... [44](#)
- Deleted open-connect and RESET state sentence from the last paragraph in the *Reset Extension* section..... [44](#)
- Changed *Power-Up and Power-Down Behavior* image in the *Power-Up and Power-Down Behavior* section ..... [45](#)
- Added notes to the *IGN Power Latch and POST-RUN Reset* image in the *Power-Up and Power-Down Behavior* section ..... [46](#)
- Deleted reset driver from ENDRV bullet in the *Safety Functions and Diagnostics Overview* section ..... [47](#)
- Added the *Voltage Monitoring Overview* table and table reference to the *Voltage Monitor (VMON)* section..... [47](#)
- Added the *Internal Error Signals* table ..... [49](#)
- Deleted loss-of-power note and cleared-latched bullet from the clock failure list in the *Loss-of-Clock Monitor (LCMON)* section ..... [51](#)
- Added SPI register bit to the latched bullet in the clock failure list in the *Loss-of-Clock Monitor (LCMON)* section ... [51](#)
- Added ABIST case paragraphs following the *Analog BIST Run States* image ..... [52](#)
- Moved *Logic Built-In Self-Test (LBIST)* section from after DMUX tables and added initialized registers list ..... [53](#)
- Deleted VDD5 and VSOUT1 supplies from first paragraph of the *Junction Temperature Monitoring and Current Limiting* section ..... [54](#)
- Added VSOUT1 supplies paragraph to the *Junction Temperature Monitoring and Current Limiting* section..... [54](#)
- Added ..... [54](#)
- Deleted STANDBY State text from the *Junction Temperature Monitoring and Current Limiting* section and changed to regulated supplies. Also added ENDRV pin..... [54](#)
- Changed third paragraph of the *Junction Temperature Monitoring and Current Limiting* section to include NRES asserted low and VDD5 reenable ..... [54](#)
- Added *Thermal and Overcurrent Protect Overview* table and table reference to the *Junction Temperature Monitoring and Current Limiting* section..... [55](#)
- Added analog and digital signals and notes to the *Diagnostic Output Pin DIAG\_OUT* image in the *Diagnostic*

Output Pin DIAG_OUT section .....	<a href="#">56</a>
• Added added disabled state description for the DIAG_OUT pin in the last paragraph of the <i>Diagnostic Output Pin DIAG_OUT</i> section .....	<a href="#">56</a>
• Added <i>accuracy</i> and corresponding table note to the voltage range column in the <i>Analog MUX Selection</i> table .....	<a href="#">57</a>
• Added $\pm$ percentage to the divide ratio values (except for MAIN_BG and VMON_BG) the <i>Analog MUX Selection</i> table .....	<a href="#">57</a>
• Changed the DIAG_MUX_SEL column and header in the <i>Analog MUX Selection</i> table .....	<a href="#">57</a>
• Added the max output resistance column to the <i>Analog MUX Selection</i> table .....	<a href="#">57</a>
• Changed VSFB1 divide ratio from 1 to 4 in the <i>Analog MUX Selection</i> Table .....	<a href="#">57</a>
• Added the voltage/signal name for signal number A.7 from BG1 to MAIN_BG in the <i>Analog MUX Selection</i> table ..	<a href="#">57</a>
• Added additional text and note to further explain the <i>Analog MUX Selection</i> Table .....	<a href="#">57</a>
• Added second paragraph to the <i>Digital MUX (DMUX)</i> section .....	<a href="#">57</a>
• Added diagnostic check text, <i>Diagnostic MUX Output state (by MUX_OUT bit)</i> , and <i>MUX interconnect check</i> section after DMUX tables .....	<a href="#">60</a>
• Changed the <i>Watchdog Enable Function</i> image in the <i>WDT Fail Counter, WDT Status, and WDT Fail Event</i> section .....	<a href="#">61</a>
• Added watchdog fail counter text after the <i>Watchdog Status for Fail Counter Value Range</i> table.....	<a href="#">61</a>
• Changed trigger events paragraph (third) in the <i>WDTI Configuration with External Trigger Input (Default Mode)</i> section .....	<a href="#">63</a>
• Added SPI register names and DIAGNOSTIC state to the open and close window programming sentence in the <i>WDTI Configuration with External Trigger Input (Default Mode)</i> section .....	<a href="#">64</a>
• Added the WDTI window sequencing and SPI SW_LOCK paragraphs in the <i>WDTI Configuration with External Trigger Input (Default Mode)</i> section .....	<a href="#">64</a>
• Added the WDTI rising edge paragraph in the <i>WDTI Configuration with External Trigger Input (Default Mode)</i> section and added $t_{WD\_pulse}$ filter time paragraph .....	<a href="#">64</a>
• Added image to the <i>WDTI Configuration with External Trigger Input (Default Mode)</i> section .....	<a href="#">65</a>
• Added image to the <i>WDTI Configuration with External Trigger Input (Default Mode)</i> section .....	<a href="#">66</a>
• Deleted ASIC reference in the first paragraph of the <i>Watchdog Question /and Answer Configuration Through SPI</i> section .....	<a href="#">67</a>
• Added <i>starts a new watchdog token-response sequence run</i> to the no-response event description in paragraph four of the <i>Watchdog Question /and Answer Configuration Through SPI</i> section .....	<a href="#">67</a>
• Added 4-bit word bullet to the <i>Watchdog Token Request</i> definition list in the <i>Watchdog-Timer-Related SPI Event Definitions</i> section .....	<a href="#">67</a>
• Added 32-bit word bullet to the <i>Watchdog Token Timer Request</i> definition list in the <i>Watchdog-Timer-Related SPI Event Definitions</i> section .....	<a href="#">68</a>
• Added <i>Watchdog Token-Response Sequence Run</i> section to replace the <i>Watchdog Timer Configuration for Question and Answer Configuration</i> section .....	<a href="#">68</a>
• Changed the <i>WDT Token and Response Sequence Run</i> image in the <i>Watchdog Token-Response Sequence Run</i> section .....	<a href="#">69</a>
• Added the 4-bit question paragraph to the <i>Watchdog Token Value Generation (or Watchdog Question Generation)</i> section .....	<a href="#">69</a>
• Added the <i>Watchdog TOKEN Generation</i> image and following text in the <i>Watchdog Timer Configuration for Question and Answer Configuration</i> section .....	<a href="#">70</a>
• Added <i>Answer Comparison and Reference Answer</i> section .....	<a href="#">72</a>
• Changed WDT answer column header names - switched response 0 and response 3, switched response 2 and response 1 in the <i>Set of 4-Bit WD Token Values and Corresponding 8-Bit Responses</i> table. Added token registerDevice Configuration Register Protection name and value to token column. ....	<a href="#">73</a>
• Added <i>Watchdog Token-Response Sequence Run and WDT_STATUS Register Updates</i> section .....	<a href="#">73</a>
• Added activation and deactivation paragraph in the <i>MCU Error Signal Monitor (MCU ESM)</i> section .....	<a href="#">75</a>
• Added DIAGNOSTIC and ACTIVE state paragraph in the <i>MCU Error Signal Monitor (MCU ESM)</i> section.....	<a href="#">76</a>
• Added deglitched and synchronized paragraph in the <i>MCU Error Signal Monitor (MCU ESM)</i> section.....	<a href="#">76</a>
• Added ERROR/WDI pin implementation text in the <i>MCU Error Signal Monitor (MCU ESM)</i> section.....	<a href="#">76</a>
• Added the first paragraph in the <i>PWM Mode</i> section and added the detect and no detect statements.....	<a href="#">78</a>
• Added monitoring lists to the <i>PWM Mode</i> section .....	<a href="#">78</a>
• Changed register setting text for the ERROR_PIN_FAIL bit from error-pin signaling failure to system clock detection to the <i>PWM Mode</i> section .....	<a href="#">80</a>
• Added CFG_CRC_ERR flag text to the <i>Device Configuration Register Protection</i> section .....	<a href="#">81</a>
• Changed CRC-8 polynomial from $X^8 + X^7 + X^6 + X^4 + X^2 + 1$ to $X^8 + X^2 + X^1 + 1$ in the <i>Device Configuration Register Protection</i> section .....	<a href="#">81</a>
• Added 64-bit string text and protected registers list in the <i>Device Configuration Register Protection</i> section.....	<a href="#">81</a>

- Added *CRC Bus Structure* table in the *Device Configuration Register Protection* section ..... [82](#)
- Added CRC calculation text, image, and table in the *Device Configuration Register Protection* section ..... [82](#)
- Added EEPROM CRC check and list of steps in the *Device Configuration Register Protection* section..... [83](#)
- Changed the *Reset and Enable Circuit* image in the *Enable and Reset Driver Circuit* section..... [84](#)
- Added ENDRV pulled low paragraph to the *Enable and Reset Driver Circuit* section ..... [84](#)
- Changed timing-response diagram description from RESET condition to any VDDx UV or OV condition in the *Enable and Reset Driver Circuit* section ..... [85](#)
- Added RESET condition image in the *Enable and Reset Driver Circuit* section and replaced it with the any VDDx UV or OV condition image ..... [85](#)
- Changed *Device Controller State Diagram* image ..... [86](#)
- Added *Internal NPOR (power-on reset)* bullet item in the *STANDBY STATE* section..... [87](#)
- Changed *IGN and CANWU driven low* bullet item to deglitched IGN, IGN\_PWRL, and CANWU\_L with values in the *STANDBY STATE* section..... [87](#)
- Added device error count text to the *SAFE* state bullet in the *RESET STATE* list ..... [87](#)
- Deleted the *ACTIVE* state bullet in the *RESET STATE* list..... [87](#)
- Added VDD5 sub-bullet in the *RESET STATE* list..... [87](#)
- Added watchdog fail counter text to the watchdog reset sub-bullet in the *RESET STATE* list ..... [87](#)
- Added ramping up sub-bullet to the first item in the *RESET STATE* list..... [88](#)
- Added *RESET State transition* paragraph to the *RESET STATE* list ..... [88](#)
- Added *NRES* pulled up to the *Enters RESET state* bullet in the *DIAGNOSTIC STATE* list ..... [88](#)
- Added *VSOUT1*, watchdog and *ERROR/WDI*, watchdog failure counter, and *ENDRV* pin bullets in the *DIAGNOSTIC STATE* list ..... [88](#)
- Added *DIAG\_EXIT\_MASK* and *DIAG\_EXIT* text to the end of the *DIAGNOSTIC STATE* list..... [88](#)
- Changed two bullets in the *ACTIVE STATE* list and added three additional bullets ..... [89](#)
- Added uncontrolled transition sub-bullet to the enters *DIAGNOSTIC* state bullet in the *SAFE STATE* list..... [90](#)
- Added *ACTIVE* state read-back error, stays in *Safe* state, *NRES*, and *VDDx* bullets in the *SAFE STATE* list ..... [90](#)
- Added *STATE TRANSITION PRIORITIES* section ..... [91](#)
- Deleted *Enters from RESET, DIAGNOSTIC, or ACTIVE state after ABIST or LBIST failure* bullet from the *SPI 4-pin* list in the *SPI Interface* section..... [92](#)
- Changed speed from 10 to 6 Mbit/s in the *SPI Interface* section ..... [92](#)
- Added minimum time sentence to paragraph after the *SPI Command Transfer Phase* table ..... [92](#)
- Deleted paragraph describing the possibility of mixing two access modes in the *SPI Data-Transfer Phase* section.. [93](#)
- Added minimum time sentence to paragraph after the *SPI Data-Transfer Phase* table ..... [93](#)
- Added status bit paragraph and note after the *Device Status Flag Byte Response* table..... [93](#)
- Added 8-bit hex column to the *SPI Command Table*..... [95](#)
- Changed D5 from 0 to 1 in the *DEV\_REV Register* table ..... [96](#)
- Changed D0 from 0 to 1 in the *DEV\_REV Register* table ..... [96](#)
- Changed D0 from 0 to 1 in the *DEV\_ID Register* table ..... [97](#)
- Changed reset value text to D[1] and D[0] descriptions in the *DEV\_STATE Register* table ..... [97](#)
- Changed D6 from *MASK\_VDD\_OV* and 1 to *nMASK\_VDD\_UV\_OV* and 0 in the *DEV\_CFG1 Register* table ..... [98](#)
- Added ground and no ground to the *SEL\_VDD3/5* description for both 5 V and 3.3 V in the *DEV\_CFG1 Register* table ..... [98](#)
- Added value in *RESET State* text in the *DEV\_CFG1 Register* table..... [98](#)
- Added *READ-ONLY* the *DEV\_CFG1 Register* table ..... [98](#)
- Added after first start-up text to D[6] if *VDD1* text in the *DEV\_CFG1 Register* table ..... [98](#)
- Switched the names of D5 and D4 in *DEV\_CFG2 Register* table ..... [99](#)
- Changed *EN\_VDD3/5\_OT* description by removing extra text after *set to 1* and adding two more bullets in the *DEV\_CFG2 Register* table ..... [99](#)
- Changed read/writable text for D[3:0] in the *DEV\_CFG2 Register* table ..... [99](#)
- Changed *AVDD\_VMON\_ERR* description from error status to power-good status in the *VMON\_STAT\_1 Register* table..... [100](#)
- Changed *set to 1* text of D[1] in the *VMON\_STAT\_1 Register* table from when error is detected to when voltage monitor < main band gap ..... [100](#)
- Changed *set to 1* text of D[0] in the *VMON\_STAT\_1 Register* table fro ..... [100](#)
- Changed m when error is detected to when voltage monitor > main band gap ..... [100](#)
- Changed name of D6 from *VDD3\_ILIM* to *VDD3\_5\_ILIM* in the *SAFETY\_STAT\_1 Register* table ..... [102](#)
- Added note to D[7] description in the *SAFETY\_STAT\_1 Register* table ..... [102](#)
- Added EEPROM bullet to D[5] description in the *SAFETY\_STAT\_2 Register* table ..... [103](#)
- Added *DIAGNOSTIC* and *ACTIVE State* text to D[2:0] default bullet in the *SAFETY\_STAT\_2 Register* table..... [103](#)
- Added cleared to text to the D[5] description in the *SAFETY\_STAT\_3 Register* table..... [104](#)

• Changed D7 and D6 from 1 to 0 in the <i>SAFETY_STAT_4 Register</i> table .....	<a href="#">105</a>
• Changed name of D0 from TRIM_ERR to TRIM_ERR_VMON in the <i>SAFETY_STAT_4 Register</i> table.....	<a href="#">105</a>
• Added cleared to bullet and note to D[7:6] description in the <i>SAFETY_STAT_4 Register</i> table.....	<a href="#">105</a>
• Changed <i>set to</i> text to include error-signal monitoring in the D[3] description in the <i>SAFETY_STAT_4 Register</i> table .....	<a href="#">105</a>
• Added ERROR_PIN_FAIL text to D[3] cleared description in the <i>SAFETY_STAT_4 Register</i> table.....	<a href="#">105</a>
• Added Watchdog Fail Counter text to the D[2] <i>set to</i> and <i>cleared to</i> descriptions in the <i>SAFETY_STAT_4 Register</i> table.....	<a href="#">105</a>
• Deleted SPI read access from D[1] <i>cleared to</i> description in the <i>SAFETY_STAT_4 Register</i> table .....	<a href="#">105</a>
• Changed SPI read access to NPOR in the D[0] <i>cleared to</i> description in the <i>SAFETY_STAT_4 Register</i> table .....	<a href="#">105</a>
• Changed D4 from 1 to 0 and D1 and D0 from 0 to 1 in the <i>SAFETY_STAT_5 Register</i> table .....	<a href="#">106</a>
• Changed threshold from max to min for the 0000 setting description in the <i>SAFETY_ERR_CFG Register</i> table ...	<a href="#">106</a>
• Changed D7 and D6 from 1 to 0 in the <i>SAFETY_BIST_CTRL Register</i> table .....	<a href="#">107</a>
• Changed D3 from LOCLK_EN to RSV in the <i>SAFETY_BIST_CTRL Register</i> table .....	<a href="#">107</a>
• Added ACTIVE state bullet to D[7:6] description in the <i>SAFETY_BIST_CTRL Register</i> table.....	<a href="#">107</a>
• Added DIAGNOSTIC and ACTIVE states to D[5] description in the <i>SAFETY_BIST_CTRL Register</i> table .....	<a href="#">107</a>
• Changed D4 from NO_WRST to RSV in the <i>SAFETY_CHECK_CTRL Register</i> table .....	<a href="#">108</a>
• Added DEV_CFG2 and DEV_CFG1 to D[7] list of protected registers in the <i>SAFETY_CHECK_CTRL Register</i> table .....	<a href="#">108</a>
• Added device state, ENDRV and NRES to D[6] description in the <i>SAFETY_CHECK_CTRL Register</i> table .....	<a href="#">108</a>
• Changed D[3] from not read/writable to read/writable in the <i>SAFETY_CHECK_CTRL Register</i> table .....	<a href="#">108</a>
• Added ERROR_PIN_FAIL sub-bullet to D[2] description in the <i>SAFETY_CHECK_CTRL Register</i> table .....	<a href="#">108</a>
• Changed D7 from 0 to 1 in the <i>SAFETY_FUNC_CFG Register</i> table.....	<a href="#">109</a>
• Changed D2 from RSV to DIS_NRES_MON in the <i>SAFETY_FUNC_CFG Register</i> table .....	<a href="#">109</a>
• Changed D0 from 0 to X in the <i>SAFETY_FUNC_CFG Register</i> table .....	<a href="#">109</a>
• Added SAFE state-time sub-bullet to the D[7] description in the <i>SAFETY_FUNC_CFG Register</i> table.....	<a href="#">109</a>
• Changed D[6] description from error-pin to Error-Signal Monitor in the <i>SAFETY_FUNC_CFG Register</i> table .....	<a href="#">109</a>
• Deleted watchdog pin from the D[6] description in the <i>SAFETY_FUNC_CFG Register</i> table .....	<a href="#">109</a>
• Added note text to the D[4] description in the <i>SAFETY_FUNC_CFG Register</i> table.....	<a href="#">109</a>
• Added STANDBY state text to the D[4] description in the <i>SAFETY_FUNC_CFG Register</i> table .....	<a href="#">109</a>
• Deleted <i>enabling/disabling the watchdog</i> bullet from the D[3] description in the <i>SAFETY_FUNC_CFG Register</i> table .....	<a href="#">109</a>
• Added bullets to the D[2] description in the <i>SAFETY_FUNC_CFG Register</i> table .....	<a href="#">109</a>
• Changed D[1] from not read/writable to read/writable in the <i>SAFETY_FUNC_CFG Register</i> table.....	<a href="#">109</a>
• Added READ-ONLY bullet, RESET STATE sub-bullet, and connected and not-connected text to the D[0] description in the <i>SAFETY_FUNC_CFG Register</i> table.....	<a href="#">109</a>
• Added ERROR/WDI and SAFE state text to the D[5] <i>set to</i> description in the <i>SAFETY_ERR_STAT Register</i> table .....	<a href="#">110</a>
• Added WD_RST_EN text to D[4] <i>set to</i> description in the <i>SAFETY_ERR_STAT Register</i> table .....	<a href="#">110</a>
• Added watchdog fail counter text to D[4] <i>cleared to</i> description in the <i>SAFETY_ERR_STAT Register</i> table.....	<a href="#">110</a>
• Added equation and oscillator text to the <i>SAFETY_ERR_PWM_H Register</i> table description .....	<a href="#">110</a>
• Changed D4, D2, and D0 from 0 to 1 in the <i>SAFETY_ERR_PWM_L Register</i> description .....	<a href="#">111</a>
• Added equations and oscillator text to the <i>SAFETY_ERR_PWM_H Register</i> table description .....	<a href="#">111</a>
• Changed D4 from 1 to 0 in the <i>SAFETY_PWD_THR_CFG Register</i> table.....	<a href="#">111</a>
• Changed _THR to PWD names for D3:D0 in the <i>SAFETY_PWD_THR_CFG Register</i> table .....	<a href="#">111</a>
• Changed D7, D5, and D3 from 1 to 0 in the <i>SAFETY_CFG_CRC Register</i> table .....	<a href="#">111</a>
• Changed D4 from 0 to 1 in the <i>SAFETY_CFG_CRC Register</i> table .....	<a href="#">111</a>
• Changed D[7] description from high-impedance to tri-stated in the <i>DIAG_CFG_CTRL Register</i> table .....	<a href="#">112</a>
• Added SDO diagnostics from D[1:0] description to the D[6] description in the <i>DIAG_CFG_CTRL Register</i> table ...	<a href="#">112</a>
• Changed D2 from 1 to 0 in the <i>WDT_TOKEN_FDBCK Register</i> table .....	<a href="#">113</a>
• Added bullets to the D[7:4] description in the <i>WDT_TOKEN_FDBCK Register</i> table .....	<a href="#">113</a>
• Added new TOKEN seed bullet and sub-bullets to the D[3:0] description in the <i>WDT_TOKEN_FDBCK Register</i> table .....	<a href="#">113</a>
• Changed D6:D0 from 0 to 1 in the <i>WDT_WIN1_CFG Register</i> table .....	<a href="#">113</a>
• Changed D4:D3 from 0 to 1 in the <i>WDT_WIN2_CFG Register</i> table.....	<a href="#">113</a>
• Changed D7 from 0 to 1 in the <i>WDT_TOKEN_VALUE Register</i> table .....	<a href="#">114</a>
• Changed MCU sub-bullet from D[7] description to replace Q&A sub-bullet in the D[3:0] description of the <i>WDT_TOKEN_VALUE Register</i> table .....	<a href="#">114</a>
• Changed D7:D6 from 0 to 1 in the <i>WDT_STATUS Register</i> table .....	<a href="#">114</a>
• Changed D7:DF from RSV to WD_WRONG_CFG in the <i>WDT_STATUS Register</i> table .....	<a href="#">114</a>

- 
- Changed *set to* text of the D[5] description in the *WDT\_STATUS Register* table ..... [114](#)
  - Changed D[4] note from recommendation to clear bit to remains set to 1 in the *SENS\_CTRL Register* table ..... [115](#)
  - Changed *Typical Application Diagram* image ..... [117](#)
-

### 3 Pin Configuration and Functions

The pin configuration drawing in this section is not to scale. For package dimensions, see the mechanical data in [Section 10](#).

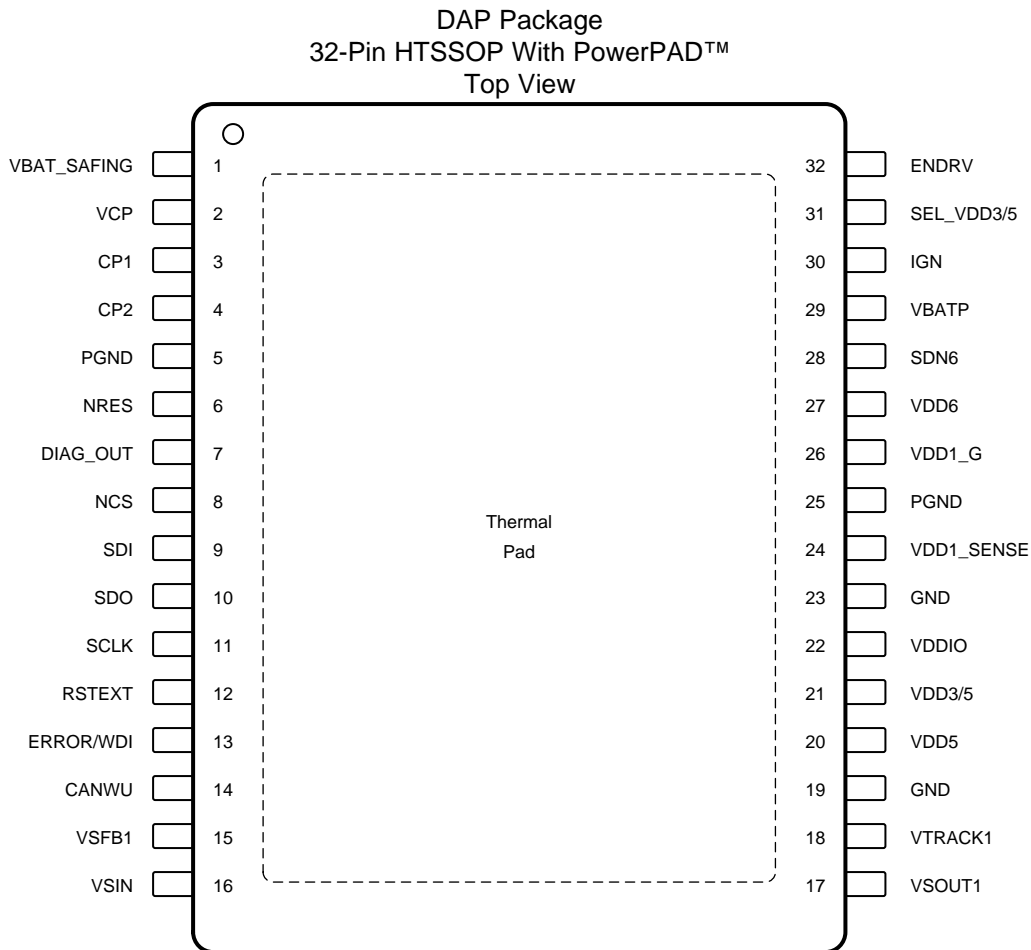

#### Pin Functions

PIN		TYPE	DESCRIPTION
NO.	NAME		
1	VBAT_SAFING	PWR	Battery (supply) input for monitoring (VMON) and BG2 functions (must be reverse protected), should be connected to VBATP
2	VCP	PWR	Charge-pump output voltage
3	CP1	PWR	Charge-pump external capacitor, high-voltage side
4	CP2	PWR	Charge-pump external capacitor, low-voltage side
5	PGND	GND	Ground (power)
6	NRES	O	Cold reset output signal for the microcontroller (MCU) (active-low, internal pullup, open drain output)
7	DIAG_OUT	O	Diagnostic output pin for diagnostic MUX. Internal analog (AMUX) and digital (DMUX) signal connection to MCU ADC and digital IO
8	NCS	I	SPI chip select (active-low, internal pullup)
9	SDI	I	SPI serial data IN (internal pulldown)
10	SDO	O	SPI serial data OUT
11	SCLK	I	SPI clock (internal pull down)
12	RSTEXT	I	Configuration pin to set reset extension time through a resistor to GND
13	ERROR/WDI		
14	CANWU		
15	VSFB1		
16	VSIN		
17	VSOUT1		
18	VTRACK1		
19	GND		
20	VDD5		
21	VDD3/5		
22	VDDIO		
23	GND		
24	VDD1_SENSE		
25	PGND		
26	VDD1_G		
27	VDD6		
28	SDN6		
29	VBATP		
30	IGN		
31	SEL_VDD3/5		
32	ENDRV		

Pin Functions (continued)

PIN		TYPE	DESCRIPTION
NO.	NAME		
13	ERROR/WDI	I	Error input signal from the MCU while using the MCU ESM (with the watchdog in Q&A Mode), trigger input for the watchdog in trigger mode (MCU ESM not used). This pin is edge triggered.
14	CANWU	I	Wake-up input from CAN transceiver, other transceiver or other source. Wake-up request latched with CANWU_L. (internal pulldown)
15	VSFB1	I	Feedback input reference for sensor supply regulator (VSOUT1)
16	VSIN	PWR	Input supply voltage for the sensor-supply regulator (VSOUT1)
17	VSOUT1	PWR	Output voltage for the VSOUT1 sensor-supply regulator
18	VTRACK1	I	Tracking input reference for sensor-supply regulator (VSOUT1) (internal pulldown)
19	GND	GND	Ground (analog)
23	GND	GND	Ground (analog)
20	VDD5	PWR	VDD5 regulator output voltage
21	VDD3/5	PWR	VDD3/5 regulator output voltage
22	VDDIO	PWR	I/O supply input for pins to and from the MCU
24	VDD1_SENSE	I	Reference input for VDD1 regulator (feedback) and input for UV/OV monitoring of VDD1 regulator
25	PGND	GND	Ground (power)
26	VDD1_G	O	Gate drive of external FET for VDD1 regulator
27	VDD6	PWR	VDD6 switch mode regulator feedback input and supply input for integrated VDD5 and VDD3/5 regulators
28	SDN6	PWR	Switching node for VDD6 switch mode regulator
29	VBATP	PWR	Battery (supply) voltage (must be reverse protected), main power supply input for device
30	IGN	I	Wake-up input from ignition (key) or other source (internal pulldown)
31	SEL_VDD3/5	I	Input selects voltage level for VDD3/5 regulator (SEL_VDD3/5 pin open: 3.3-V regulation from VDD3/5; SEL_VDD3/5 pin to GND: 5-V regulation from VDD3/5)
32	ENDRV	O	Enable output signal for peripherals (for example, motor-driver IC), safing path output (internal pullup, open drain output)
—	Thermal pad	—	Place thermal vias to large ground plane and connect to GND and PGND pins.

## 4 Specifications

### 4.1 Absolute Maximum Ratings

Over operating free-air temperature range (unless otherwise noted)<sup>(1)(2)</sup>

POS			MIN	MAX	UNIT
M1.1	Protected-battery voltage	VBATP, VBAT_SAFING, VSIN	-0.3	40	V
M1.2	Charge-pump voltage	VCP, CP1 <sup>(3)</sup>	-0.3	lesser of VBATP + 16 or 52	V
M1.3	Charge-pump pumping capacitor voltage	CP2	-0.3	40	V
M1.3a	Charge-pump overdrive voltage	VCP <sup>(3)</sup> -VBATP	-0.3	16	V
M1.4	VDD6 switching-node voltage	SDN6	-0.3	40	V
M1.5	VDD6 output voltage	VDD6	-0.3	40	V
M1.6	VDD5 output voltage	VDD5	-0.3	7	V
M1.7	VDD3/5 output voltage	VDD3/5	-0.3	7	V
M1.8	VDD1_G voltage	VDD1_G	-0.3	15	V
M1.10	VDD1_SENSE voltage	VDD1_SENSE	-0.3	7	V
M1.11	Sensor supply tracking voltage	VTRACK1	-0.3	40	V
M1.12	Sensor supply output and feedback voltage	VSOUT1, VSFB1 <sup>(4)</sup>	-2	18	V
M1.14	Analog/digital reference output voltage	DIAG_OUT	-0.3	7	V
M1.15	Logic I/O voltage	VDDIO, ERROR/WDI, ENDRV, NRES, NCS, SDI, SDO, SCLK, RSTEXT	-0.3	7	V
M1.16		SEL_VDD3/5	-0.3	40	V
M1.17	IGN wakeup	IGN	-7	40	V
M1.18	CAN wakeup	CANWU	-0.3	40	V
M1.19	Operating virtual junction temperature, T <sub>J</sub>			150	°C
	Storage temperature, T <sub>stg</sub>		-65	150	°C

- (1) Stresses beyond those listed under *Absolute Maximum Ratings* may cause permanent damage to the device. These are stress ratings only, which do not imply functional operation of the device at these or any other conditions beyond those indicated under *Recommended Operating Conditions*. Exposure to absolute-maximum-rated conditions for extended periods may affect device reliability.
- (2) All voltage values are with respect to the network ground pin unless otherwise noted.
- (3) VCP and CP1 are output pins, no external voltage should be applied to these pins. Absolute Maximum ratings for these pins are what may appear on the pins.
- (4) VSOUT1 is connected to VSFB1 directly (for unity gain) or through resistor divider (tracking mode gain or non-tracking mode output voltage adjusting). In case of a short to supply fault, the voltage on VSOUT1 is equal to the supply to the device (VBATP, VBAT\_SAFING, and VSIN where VSIN is connected to VBATP as it's supply instead of VDD6) and VSFB1 voltage will follow VSOUT1 based on the use case, directly (for unity gain) or via resistor divider (tracking mode gain or non-tracking mode output voltage adjusting).

### 4.2 ESD Ratings

POS.			VALUE	UNIT		
M1.21	V <sub>(ESD)</sub>	Electrostatic discharge	Human body model (HBM), per AEC Q100-002 <sup>(1)</sup>	All pins except VSOUT1 (17) and VSFB1 (15)	±2000	V
M1.20				On sensor supply pins VSOUT1 (17) and VSFB1 (15)	±4000	
M1.22		Charged device model (CDM), per AEC Q100-011	Corner pins (1, 16, 17, and 32)	±750		
M1.23			All pins	±500		

- (1) AEC Q100-002 indicates that HBM stressing is done in accordance with the ANSI/ESDA/JEDEC JS-001 Specification.

### 4.3 Recommended Operating Conditions

Over operating temperature range and with respect to the GND and PGND (GND = PGND) pins (unless otherwise noted)

POS		MIN	MAX	UNIT
M1.20a	Operating ambient temperature, $T_A$	-40	125	°C
R1.1	Minimum input supply voltage on VBATP for initial power up (POS 6.2, $VBATP\_UV_{on}$ ) <sup>(1)(2)</sup>		5.8 <sup>(3)</sup>	V
R1.2	Input supply voltage on VBATP <sup>(1)(2)(4)</sup> <ul style="list-style-type: none"> <li>To support operation when VBATP is between 5.8 V and 7 V, the device remains functional. Some rails can be in dropout or undervoltage depending on actual input supply and the configuration of the specific regulator.</li> <li>VDD6 can be in dropout mode (100% duty cycle)</li> <li>VDD3/5 configured for 5-V output can be in dropout. If the output reaches VDD3/5_UV threshold, the device transitions to the RESET state because of a VDD3/5 undervoltage event. If VDD3/5 is configured for 3.3-V output it remains functional.</li> <li>VDD5 can be in dropout. If output reaches the VDD5_UV threshold, the device indicates the undervoltage event through the VDD5_UV status bit.</li> <li>VSOUT1 can be in dropout depending on configuration. If output reaches VSOUT1_UV threshold, the device indicates the undervoltage event through the VSOUT1_UV status bit.</li> </ul>	5.8	34 <sup>(5)</sup>	V
R1.3	Input supply voltage on VBATP after initial power up, functional operation during low input supply voltage events, (POS 6.1, $VBATP\_UV_{off}$ ) <sup>(1)(6)</sup> <ul style="list-style-type: none"> <li>The device remains functional. Some rails can be in dropout or undervoltage depending on actual input supply and the configuration of the specific regulator.</li> <li>VDD6 is in dropout mode (100% duty cycle).</li> <li>VDD3/5 configured for 5-V output can be in dropout. If the output reaches VDD3/5_UV threshold, the device transitions to the RESET state because of a VDD3/5 undervoltage event. If VDD3/5 is configured for 3.3-V output it remains functional.</li> <li>VDD5 can be in dropout. If the output reaches VDD5_UV threshold, the device indicates the undervoltage event through the VDD5_UV status bit.</li> <li>VSOUT1 may be in dropout depending on configuration, if output reaches VSOUT1_UV threshold the device indicates the undervoltage event through the VSOUT1_UV status bit.</li> </ul>	4.5	5.8	V
R1.4	VDDIO supply-voltage range	3.3	5	V
R1.5	Current consumption in standby mode (all regulator outputs disabled) IGN = 0 V, CANWU = 0 V, 5.8 V ≤ VBAT ≤ 20 V for $T_J < 85^\circ\text{C}$ or 5.8 V ≤ VBAT ≤ 14 V for $T_J = 125^\circ\text{C}$		75	μA

- (1) VBATP should be connected to VBAT\_SAFING.
- (2) VBAT\_SAFING has a supply high enough to power the VMON block and internal rail AVDD\_VMON above AVDD\_VMON\_UV.
- (3) The device may power up when VBATP is less than 5.8 V, but it will always power up when VBATP is 5.8V or greater, while VBAT\_SAFING has a supply high enough to power the VMON block and internal rail AVDD\_VMON above AVDD\_VMON\_UV.
- (4) Under slow VBAT ramp-down and when VDD3/5 rail is configured as a 5-V rail, the NRES output can be pulled low when VBAT is at approximately 6.3 V. This occurs because of an undervoltage transient on the VDD3/5 rail.  
Under slow VBAT ramp-up and when VDD3/5 rail is configured as a 5-V rail, the NRES output can be pulled low when VBAT is at approximately 6.6 V. This occurs because of an undervoltage transient on VDD3/5 rail. Under similar conditions, undervoltage transients are observed on VDD5 and VSOUT1 rails (refer to [Device Behavior Under Slow VBAT Ramp-Up and Ramp-Down](#)).
- (5) The recommended maximum operating voltage for VBATP and VBAT\_SAFING is listed as 34 V, just below the overvoltage detection thresholds for VBATP,  $VBATP\_OV_{rise}$  and  $VBATP\_OV_{fall}$ . TI recommends enabling overvoltage detection on VBATP (default is enabled, MASK\_VBATP\_OV = 0). TI also recommends evaluating the thermal and power dissipation of the device in the application and ensure the design has adequate thermal management for operation at the necessary supply voltage level.
- (6) The device will remain on if VBATP drops from 5.8V down to  $VBATP\_UV_{off}$  threshold or another voltage monitor detects an undervoltage on a specific rail and changes the device state.  $VBAT\_UV_{off}$  can be detected at 4.5 V but could be detected as low as 4.2 V. VBAT\_SAFING has a supply high enough to power the VMON block and internal rail AVDD\_VMON above AVDD\_VMON\_UV.

#### 4.4 Thermal Information

THERMAL METRIC <sup>(1)</sup>		TPS65381-Q1	UNIT
		DAP (HTSSOP)	
		32 PINS	
R <sub>θJA</sub>	Junction-to-ambient thermal resistance	26.3	°C/W
R <sub>θJC(top)</sub>	Junction-to-case (top) thermal resistance	14.1	°C/W
R <sub>θJB</sub>	Junction-to-board thermal resistance	6	°C/W
Ψ <sub>JT</sub>	Junction-to-top characterization parameter	0.2	°C/W
Ψ <sub>JB</sub>	Junction-to-board characterization parameter	6.2	°C/W
R <sub>θJC(bot)</sub>	Junction-to-case (bottom) thermal resistance	0.5	°C/W

(1) For more information about traditional and new thermal metrics, see the [Semiconductor and IC Package Thermal Metrics](#) application report.

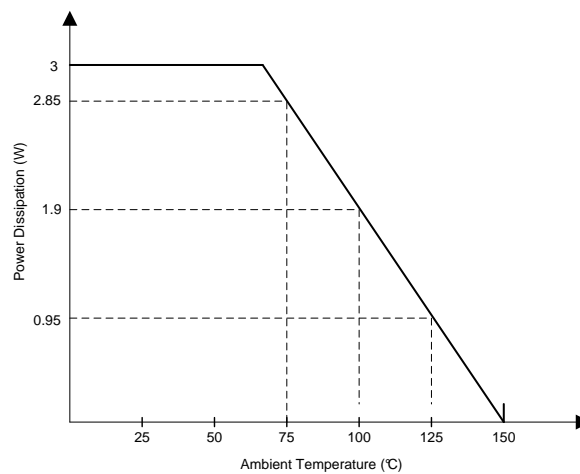

- (1) In applications where high power dissipation and/or poor package thermal resistance is present, the maximum ambient temperature may have to be derated. Maximum ambient temperature ( $T_{Amax}$ ) is dependent on the maximum-operating junction temperature ( $T_{Jmax}$ ), the maximum power dissipation of the device in the application ( $P_{Dmax}$ ), and the junction-to-ambient thermal resistance of the part/package in the application ( $R_{\theta JA}$ ), as given by the following equation:  $T_{Amax} = T_{Jmax} - (R_{\theta JA} \times P_{Dmax})$ .
- (2) Maximum power dissipation is a function of  $T_{Jmax}$ ,  $R_{\theta JA}$ , and  $T_A$ . The maximum-allowable power dissipation at any allowable ambient temperature is  $P_D = (T_{Jmax} - T_A) / R_{\theta JA}$ .

**Figure 4-1. Derating Profile for Power Dissipation Based on High-K JEDEC PCB**

## 4.5 Electrical Characteristics

Over operating ambient temperature  $T_A = -40^{\circ}\text{C}$  to the maximum-operating junction temperature  $T_J = 150^{\circ}\text{C}$ , and with  $\text{VBATP} = \text{VBAT\_SAFING}$  in the recommended operating range (see R1.2 in [Section 4.3](#)) (unless otherwise noted)

POS	PARAMETER		TEST CONDITIONS	MIN	TYP	MAX	UNIT
<b>VDD6-BUCK WITH INTERNAL FET</b>							
AN	$C_{\text{VDD6}}$	Value of output ceramic capacitor <sup>(1)</sup>	ESR range 100 m $\Omega$ to 300 m $\Omega$ <sup>(2)</sup>	22		47	$\mu\text{F}$
AN	$L_{\text{VDD6}}$	Value of inductor		22	33		$\mu\text{H}$
1.1	VDD6	VDD6 output voltage	Average DC value excluding ripple and load transients, $\text{VBAT} > 7\text{ V}$ , $0 < I_{\text{VDD6}} < 1.3\text{ A}$ , including dc line and load regulation, temperature drift, and long-term drift where $\text{VBAT} = \text{VBATP} = \text{VBAT\_SAFING}$	5.4	6	6.6	V
1.1a	$\text{VDD6}_{\text{ripple}}$	VDD6 ripple voltage	Peak-to-peak, ensured by design $\text{VBATP} = \text{VBAT\_SAFING} = 14\text{ V}$ , $L = 33\ \mu\text{H}$ , $C = 22\ \mu\text{F}$		200		mV
1.2	$I_{\text{VDD6}}$	VDD6 output current $I_{\text{VDD5}} + I_{\text{VDD3/5}} + I_{\text{VDD1}} + I_{\text{VSOUT1}}$ <sup>(3)</sup>				1.3	A
1.3	$V_{\text{dropout6}}$	VDD6 output dropout voltage $V_{\text{dropout6}} = (\text{VBATP} - \text{SDN6})$	$I_{\text{VDD6}} = 1.3\text{ A}$ (example: $R_{\text{DS(on)}} = 0.46\ \Omega$ )			0.6	V
1.4	$I_{\text{VDD6\_limit}}$	Peak current out of SDN6 pin <sup>(4)</sup>		1.5		2.5	A
1.5	$f_{\text{clk\_VDD6}}$	Clock Frequency <sup>(5)</sup>		396	440	484	kHz
1.6	$\text{DC}_{\text{VDD6}}$	$t_{\text{on}}/t_{\text{period}}$	$0 < I_{\text{VDD6}} < 1.3\text{ A}$ VDD6 enters dropout mode (100% duty cycle) for $\text{VBATP} < 7\text{ V}$	7% <sup>(6)</sup>		100%	
1.7	$T_{\text{protVDD6}}$	Temperature protection threshold <sup>(7)</sup>		175		210	$^{\circ}\text{C}$
<b>VDD5 – LDO WITH INTERNAL FET</b>							
AN	$C_{\text{VDD5}}$	Value of output ceramic capacitor	ESR range 0 m $\Omega$ to 100 m $\Omega$	1		5	$\mu\text{F}$
2.1	VDD5	VDD5 output voltage <sup>(8)</sup>	$0 < I_{\text{VDD5}} < 300\text{ mA}$	4.9	5	5.1	V
2.2	$I_{\text{VDD5}}$	VDD5 output current, including load from the internal resistor of 660 $\Omega$ (typical)				300	mA
2.3	$\text{VDD5}_{\text{dyn}}$	VDD5 output voltage dynamic	Load step 20% to 80% in 5 $\mu\text{s}$ , with $C_{\text{VDD5}} = 5\ \mu\text{F}$	4.85	5	5.15	V
2.4	$\text{VDD5}_{\text{max}}$	Maximum VDD5 output voltage during VBATP step from 5.5 V to 13.5 V within 10 $\mu\text{s}$	$C_{\text{VDD5}} = 5\ \mu\text{F}$ , $I_{\text{VDD5}} < 300\text{ mA}$			5.5	V
2.5	$V_{\text{dropout5}}$	VDD5 output dropout voltage $V_{\text{dropout5}} = (\text{VDD6} - \text{VDD5})$	$I_{\text{VDD5}} < 300\text{ mA}$			0.3	V
2.6	$\text{PSRR}_{\text{VDD5}}$	Power supply rejection ratio	$50 < f < 20\text{ kHz}$ , $\text{VBATP} = 10\text{ V}$ , $U = 4\text{ Vpp}$ , $C_{\text{VDD5}} = 5\ \mu\text{F}$ , $0 < I_{\text{VDD5}} < 300\text{ mA}$		> 40		dB
2.7	$\text{LnReg}_{\text{VDD5}}$	Line regulation ( $I_{\text{VDD5}}$ constant)	$0 < I_{\text{VDD5}} < 300\text{ mA}$ , $8\text{ V} < \text{VBATP} < 19\text{ V}$	-25		25	mV
2.8	$\text{LdReg}_{\text{VDD5}}$	Load regulation (VDD6 constant)	$0 < I_{\text{VDD5}} < 300\text{ mA}$ , $8\text{ V} < \text{VBATP} < 19\text{ V}$	-25		25	mV
2.9	$\text{TmpCo}_{\text{VDD5}}$	Temperature drift	Normalized to 25 $^{\circ}\text{C}$ value	-0.5%		0.5%	
2.11	$d\text{VDD5}/dt$	$dV/dt$ at VDD5 at startup	Between 10% and 90% of VDD5 end-value	5		50	V/ms
2.13	$T_{\text{protVDD5}}$	Temperature protection threshold <sup>(9)</sup>		175		210	$^{\circ}\text{C}$
2.14	$I_{\text{VDD5\_limit}}$	Current-limit <sup>(10)</sup>		350		650	mA

- (1) Capacitance is effective capacitance after derating for operating voltage, temperature, and lifetime.
  - (2) ESR is total effective series resistance of the capacitors and if necessary added series resistor.
  - (3)  $I_{\text{VDD6}}$  is the load current from VDD5, VDD3/5, VDD1 and VSOUT1 on VDD6 regulator; VDD6 is not recommended to be loaded directly for applications or peripherals that cannot operate with wider tolerance and ripple since VDD6 is a pre-regulator. However, LDOs or DC-DC conv
- erters may be connected directly as along as the total load current on VDD6,  $I_{\text{VDD6}}$ , does not exceed the specification for VDD6 load current.
- (4) VDD6 current limit is based on the peak current through SDN6 switch, it will not directly correspond to an average current limit.
  - (5) Actual switching on SND6 depends on whether output voltage on VDD6 is above or below hysteretic PWM comparator threshold at the moment of the rising edge of the  $F_{\text{clk\_VDD6}}$  clock. If no switching is needed when the rising edge of the  $F_{\text{clk\_VDD6}}$  clock occurs, SDN6 will not switch on. SDN6 turn off is determined by the hysteretic PWM comparator threshold, when the actual VDD6 voltage is above the threshold SDN6 will turn off.
  - (6) When the VDD6 control loop turns the SDN6 switch on at the rising edge of a  $f_{\text{clk\_VDD6}}$  clock cycle, SDN6 will remain on with a minimum duty cycle of 7%. However, if the control loop skips a clock cycle the duty cycle will be 0% for that  $f_{\text{clk\_VDD6}}$  clock cycle.
  - (7) Protection of VDD6, shared with VDD3/5 overtemperature protection.
  - (8) VDD5 output regulation includes line and load regulation, temperature drift.
  - (9) Protection of VDD5. In case of detected overtemperature, only VDD5 will be switched off.
  - (10)  $I_{\text{VDD5\_limit}}$  current limit has snap back behavior. During a short circuit condition, a transient current higher than the maximum will occur until the current limit snaps back into the specified range.

## Electrical Characteristics (continued)

Over operating ambient temperature  $T_A = -40^\circ\text{C}$  to the maximum-operating junction temperature  $T_J = 150^\circ\text{C}$ , and with  $V_{B\text{ATP}} = V_{\text{BAT\_SAFING}}$  in the recommended operating range (see R1.2 in Section 4.3) (unless otherwise noted)

POS	PARAMETER		TEST CONDITIONS	MIN	TYP	MAX	UNIT	
<b>VDD3/5 – LDO WITH INTERNAL FET</b>								
AN	$C_{VDD3/5}$	Value of output ceramic capacitor	ESR range 0 m $\Omega$ to 100 m $\Omega$	1		5	$\mu\text{F}$	
3.1a	VDD3/5	VDD3/5 output voltage, SEL_VDD3/5 pin: open = 3.3 V setting, ground = 5 V setting	0 < $I_{VDD3/5}$ < 300 mA	3.3-V Setting	3.234	3.3	3.366	
3.1b				5-V Setting	4.9	5	5.1	
3.2	$I_{VDD3/5}$	VDD3/5 output current, including load from the internal resistor of 440 $\Omega$ (typ.) for 3.3 V setting or 660 $\Omega$ (typ.) for 5 V setting <sup>(11)</sup>				300	mA	
3.3a	VDD3/5 <sub>dyn</sub>	VDD3/5 output voltage dynamic	Load step 20% to 80% in 5 $\mu\text{s}$ , with $C_{VDD3/5} = 5 \mu\text{F}$	3.3-V Setting	3.15	3.3	3.43	
3.3b				5-V Setting	4.85	5	5.15	
3.4	VDD3/5 <sub>max</sub>	Maximum VDD3/5 output voltage during VBATP step from 5.5 V to 13.5 V within 10 $\mu\text{s}$	$C_{VDD3/5} = 5 \mu\text{F}$ , $I_{VDD3/5} < 300 \text{ mA}$				3.6	
				5-V Setting			5.5	
3.5	Vdropout3/5	VDD3/5 output dropout voltage Vdropout3/5 = (VDD6–VDD3/5)	$I_{VDD3/5} < 300 \text{ mA}$				0.3	
3.6	PSRR <sub>VDD3/5</sub>	Power-supply rejection ratio	50 < f < 20 kHz, $V_{B\text{ATP}} = 10 \text{ V}$ , U = 4 Vpp $C_{VDD3/5} = 5 \mu\text{F}$ , 0 < $I_{VDD3/5} < 300 \text{ mA}$		> 40		dB	
3.7	LnReg <sub>VDD3/5</sub>	Line regulation ( $I_{VDD3}$ constant)	0 < $I_{VDD3/5} < 300 \text{ mA}$ , 8 V < $V_{B\text{ATP}} < 19 \text{ V}$		-25	25	mV	
3.8	LdReg <sub>VDD3/5</sub>	Load regulation (VDD6 constant)	0 < $I_{VDD3/5} < 300 \text{ mA}$ , 8 V < $V_{B\text{ATP}} < 19 \text{ V}$		-25	25	mV	
3.9	TmpCo <sub>VDD3/5</sub>	Temperature drift	Normalized to 25°C value		-0.5%	0.5%		
3.11	dVDD35/dt	dV/dt at VDD3/5 at start-up	Between 10% and 90% of VDD3/5 end-value	3.3-V Setting	3		30	
				5-V Setting	5		50	
3.13	T <sub>prot</sub> <sub>VDD3/5</sub>	Temperature protection threshold <sup>(12)</sup>			175	210	°C	
3.14	$I_{VDD3/5\_limit}$	Current-limit <sup>(13)</sup>			350	650	mA	
3.15	$I_{pu\_SEL\_VDD3/5}$	Pullup current on SEL_VDD3/5 pin				20	$\mu\text{A}$	
<b>VDD1 – LDO WITH EXTERNAL FET</b>								
AN	V <sub>gs(th)</sub>	Gate threshold voltage, external FET	ID = 1 mA	0.3		3	V	
AN	C <sub>iss</sub>	Gate capacitance, external FET	VGS = 0 V			3200	pF	
AN	Q <sub>gate</sub>	Gate Charge, external FET	VGS = 0 V to 10 V			70	nC	
AN	g <sub>fs</sub>	Forward transconductance, external FET	ID = 50 mA	0.4			S	
AN	$C_{VDD1}$	Value of output ceramic capacitor	ESR range 0 m $\Omega$ to 100 m $\Omega$	5		40	$\mu\text{F}$	
4.1	VDD1	VDD1 output voltage, depends on external resistive divider		0.8		3.3	V	
4.2	VDD1 <sub>SENSE</sub>	VDD1 reference voltage <sup>(14)</sup>	10 mA < $I_{VDD1} < 600 \text{ mA}$	0.792	0.8	0.808	V	
4.2a	VDD1 <sub>SENSE\_BIAS</sub>	Bias current of VDD1 <sub>SENSE</sub>		-6.6		-10	$\mu\text{A}$	
4.3	$I_{VDD1}$	VDD1 output current	Minimum current realized with external resistive divider	10		600	mA	
4.4	VDD1 <sub>G</sub>	VDD1_G output voltage	Referenced to GND			15	V	
4.5	VDD1 <sub>G\_off</sub>	VDD1_G voltage in OFF condition	20 $\mu\text{A}$ into VDD1_G pin			0.3	V	
4.6	$I_{VDD1\_G}$	VDD1_G DC load current				200	$\mu\text{A}$	
4.7	VDD1 <sub>dyn</sub>	VDD1 output voltage dynamic	Load step 10% to 90% in 1 $\mu\text{s}$ , with $C_{VDD1} = 40 \mu\text{F}$ <sup>(15)</sup>		$\pm 4\%$			
4.8	VDD1 <sub>max</sub>	Maximum VDD1 output voltage during VBATP step from 5.5 V to 13.5 V within 10 $\mu\text{s}$	$C_{VDD1} > 6 \mu\text{F}$ , $I_{VDD1} < 600 \text{ mA}$	VDD1 = 0.8-V output			0.898	
				VDD1 = 1.23-V output				1.287
				VDD1 = 3.3-V output				3.435
4.9	PSRR <sub>VDD1</sub>	Power-supply rejection ratio	50 < f < 20 kHz, $V_{B\text{ATP}} = 10 \text{ V}$ , U = 4 Vpp, $C_{VDD1} = 10 \mu\text{F}$ , 10 mA < $I_{VDD1} < 600 \text{ mA}$		> 40		dB	
4.10	LnReg <sub>VDD1</sub>	Line regulation on VDD1_SENSE ( $I_{VDD1}$ constant)	10 mA < $I_{VDD1} < 600 \text{ mA}$ , 8 V < $V_{B\text{ATP}} < 19 \text{ V}$		-7	7	mV	
4.11	LdReg <sub>VDD1</sub>	Load regulation on VDD1_SENSE (VDD6 constant)	10 mA < $I_{VDD1} < 600 \text{ mA}$ , 8 V < $V_{B\text{ATP}} < 19 \text{ V}$		-7	7	mV	

(11) Less than 50% of maximum loading of  $I_{VDD3/5}$  should be placed on the VDD3/5 regulator before NRES goes high during device power up.

(12) Protection of VDD3/5, treated as global overtemperature (shutdown for all regulators).

(13)  $I_{VDD3/5\_limit}$  current limit has snap back behavior. During a short circuit condition, a transient current higher than the maximum will occur until the current limit snaps back into the specified range.

(14) VDD1 regulation including line and load regulation, temperature drift and long-term drift. Does not include tolerance of resistor divider to set VDD1 output voltage.

(15) VDD1<sub>dyn</sub> will depend on external FET choice

**Electrical Characteristics (continued)**

Over operating ambient temperature  $T_A = -40^\circ\text{C}$  to the maximum-operating junction temperature  $T_J = 150^\circ\text{C}$ , and with  $\text{VBATP} = \text{VBAT\_SAFING}$  in the recommended operating range (see R1.2 in Section 4.3) (unless otherwise noted)

POS	PARAMETER		TEST CONDITIONS	MIN	TYP	MAX	UNIT
4.12	$\text{TmpCo}_{\text{VDD1}}$	Temperature drift	Normalized to 25°C value	-0.5%		0.5%	
4.14	$d\text{VDD1}/dt$	$dV/dt$ at $\text{VDD1\_SENSE}$ at start-up	Between 10% and 90% of $\text{VDD1}$ end-value	0.8		8	V/ms
<b>VSOUT1 – LDO WITH PROTECTED INTERNAL FET</b>							
AN	$\text{C}_{\text{VSOUT1}}$	Value of output ceramic capacitor	ESR range 0 mΩ to 100 mΩ	0.5		10	μF
5.1	$\text{VSOUT1}$	$\text{VSOUT1}$ output voltage, depends on external resistive divider and tracking or non-tracking mode		3.3		9.5	V
5.2	$\text{MV}_{\text{VSOUT1}}$	For tracking mode: Matching output error $\text{MV}_{\text{VSOUT1}} = (\text{VTRACK1} - \text{VSFB1})^{(16)}$	$0 < I_{\text{VSOUT1}} < 100 \text{ mA}$	-35		35	mV
5.3	$\text{VSFB1}$	For non-tracking mode: $\text{VSOUT1}$ reference voltage <sup>(17)</sup>	$10 \text{ mA} < I_{\text{VSOUT1}} < 100 \text{ mA}$	2.45	2.5	2.55	V
5.3a	$\text{VTRACK1}_{\text{th}}$	Threshold for selecting tracking/non-tracking mode ( $\text{VTRACK1} > \text{VTRACK1}_{\text{th,max}}$ V for tracking mode, $\text{VTRACK1} < \text{VTRACK1}_{\text{th,min}}$ V non-tracking mode)		1.1	1.2	1.3	V
5.3b	$\text{VTRACK1}_{\text{pd}}$	Internal pulldown resistance on $\text{VTRACK1}$ pin			100		kΩ
5.4	$I_{\text{VSOUT1}}$	$\text{VSOUT1}$ output current, including internal resistor to dissipate minimum current <sup>(18)</sup>				100	mA
5.5	$\text{VdrS1}$	$\text{VSOUT1}$ dropout voltage $\text{VdrS1} = (\text{VSIN} - \text{VSOUT1})$	$0 < I_{\text{VSOUT1}} < 100 \text{ mA}$			0.75	V
5.6	$\text{PSRR}_{\text{VSOUT1}}$	Power-supply rejection ratio	With $\text{VTRACK1} = \text{GND}$ , $\text{VSOUT1} = 4.5\text{V}$ , $50 < f < 20 \text{ kHz}$ , $\text{VSIN} = 10 \text{ V}$ , $U = 4 \text{ Vpp}$ $\text{C}_{\text{VSOUT1}} = 1 \mu\text{F}$ , $0 < I_{\text{VSOUT1}} < 100 \text{ mA}$ ,		> 40		dB
5.7	$\text{LnReg}_{\text{VSOUT1}}$	Line regulation ( $I_{\text{VSOUT1}}$ constant)	$0 < I_{\text{VSOUT1}} < 100 \text{ mA}$ , $8 \text{ V} < \text{VSIN} < 19 \text{ V}$	-25		25	mV
5.8	$\text{LdReg}_{\text{VSOUT1}}$	Load regulation ( $\text{VSIN}$ constant)	$0 < I_{\text{VSOUT1}} < 100 \text{ mA}$ , $8 \text{ V} < \text{VSIN} < 19 \text{ V}$	-35		35	mV
5.9	$\text{TmpCo}_{\text{VSOUT1}}$	Temperature drift	Normalized to 25°C value	-0.5%		0.5%	
5.11	$\text{VSOUT1}_{\text{SH}}$	Output short circuit voltage range	$\text{VSOUT1}$ ( $\text{VSFB1}$ configured for regulation) <sup>(19)</sup>	-2		18	V
5.12	$-I_{\text{VSIN}}$	Output reverse current	$\text{VSOUT1} = 14 \text{ V}$ and $\text{VBATP} = 0 \text{ V}$ , regulator switched off			20	mA
5.13	$\text{T}_{\text{protVSOUT1}}$	Temperature protection threshold <sup>(20)</sup>		175		210	°C
5.14	$I_{\text{VSOUT1\_limit}}$	Current-limit		120		500	mA
<b>VOLTAGE MONITORING</b>							
6.1	$\text{VBATP\_UV}_{\text{off}}$	$\text{VBATP}$ and $\text{VBAT\_SAFING}$ level for indication by $\text{VBAT\_UV}$ comparator <sup>(21)</sup>	$\text{VBATP} = \text{VBAT\_SAFING}$	4.2		4.5	V
6.2	$\text{VBATP\_UV}_{\text{on}}$	$\text{VBATP}$ and $\text{VBAT\_SAFING}$ level for indication by $\text{VBAT\_UV}$ comparator <sup>(21)</sup>	$\text{VBATP} = \text{VBAT\_SAFING}$	5.4		5.8	V
6.3	$\text{VBATP\_UV}_{\text{hys}}$	Undervoltage hysteresis	$\text{VBATP} = \text{VBAT\_SAFING}$	1.1		1.4	V
6.4	$\text{VBATP\_OV}_{\text{rise}}$	$\text{VBATP}$ level for setting $\text{VBAT\_OV}$ flag <sup>(22)</sup>	$\text{VBATP} = \text{VBAT\_SAFING}$	34.7		36.7	V
6.5	$\text{VBATP\_OV}_{\text{fall}}$	$\text{VBATP}$ level for clearing $\text{VBAT\_OV}$ flag <sup>(23)</sup>	$\text{VBATP} = \text{VBAT\_SAFING}$	34.4		36.3	V
6.8	$\text{VDD5\_UV}$	$\text{VDD5}$ undervoltage level	$\text{VBATP} = \text{VBAT\_SAFING}$	4.5		4.85	V
6.8a		Hysteresis	$\text{VBATP} = \text{VBAT\_SAFING}$		140		mV
6.9	$\text{VDD5\_UV}_{\text{head}}$	$\text{VDD5}$ undervoltage headroom ( $\text{VDD5act} - \text{VDD5\_UVact}$ )	$\text{VBATP} = \text{VBAT\_SAFING}$	200			mV
6.10	$\text{VDD5\_OV}$	$\text{VDD5}$ overvoltage level	$\text{VBATP} = \text{VBAT\_SAFING}$	5.2		5.45	V
6.10a		Hysteresis	$\text{VBATP} = \text{VBAT\_SAFING}$		140		mV
6.11	$\text{VDD5\_OV}_{\text{head}}$	$\text{VDD5}$ overvoltage headroom ( $\text{VDD5\_OVact} - \text{VDD5act}$ )	$\text{VBATP} = \text{VBAT\_SAFING}$	200			mV

(16) Referenced to  $\text{VTRACK1}$  input, including long-term and temperature drift.

(17)  $\text{VSOUT1}$  including line and load regulation, temperature drift and long-term drift.

(18)  $\text{VSOUT1}$  maximum power dissipation for the internal FET must not exceed 0.6 W to avoid overtemperature. Special consideration must be taken for output voltages greater than 5 V and when  $\text{VBATP}$  is used to supply  $\text{VSIN}$  instead of  $\text{VDD6}$ .

(19)  $\text{VSOUT1}$  is connected to  $\text{VSFB1}$  directly (for unity gain) or through resistor divider (tracking mode gain or non-tracking mode output voltage adjusting). In case of a short to supply fault, the voltage on  $\text{VSOUT1}$  is equal to the supply to the device ( $\text{VBATP}$ ,  $\text{VBAT\_SAFING}$ , and  $\text{VSIN}$  where  $\text{VSIN}$  is connected to  $\text{VBATP}$  as its supply instead of  $\text{VDD6}$ ) and  $\text{VSFB1}$  voltage will follow  $\text{VSOUT1}$  based on the use case, directly (for unity gain) or via resistor divider (tracking mode gain or non-tracking mode output voltage adjusting).

(20) Protection of  $\text{VSOUT1}$  Sensor Supply. Only  $\text{VSOUT1}$  switch-offs off.

(21)  $\text{VBATP\_UV}_{\text{off}}$  and  $\text{VBATP\_UV}_{\text{on}}$  are the threshold levels for  $\text{VBATP}$  where  $\text{UV}$  will be indicated by the  $\text{VBAT\_UV}$  bit in  $\text{VMON\_STAT}_1$  register. The  $\text{VBATP}$  level that will allow device power up is outlined by R1.1.

(22) Brings device into the  $\text{RESET}$  state and sets flag in  $\text{SPI}$

(23) Clears flag in  $\text{SPI}$

**Electrical Characteristics (continued)**

Over operating ambient temperature  $T_A = -40^\circ\text{C}$  to the maximum-operating junction temperature  $T_J = 150^\circ\text{C}$ , and with  $\text{VBATP} = \text{VBAT\_SAFING}$  in the recommended operating range (see R1.2 in [Section 4.3](#)) (unless otherwise noted)

POS	PARAMETER		TEST CONDITIONS	MIN	TYP	MAX	UNIT
6.12	VDD3/5_UV	VDD3/5 undervoltage level	VBATP = VBAT_SAFING	3.3-V setting 5-V setting	3 4.5	3.17 4.85	V
6.12a		Hysteresis	VBATP = VBAT_SAFING	3.3-V setting 5-V setting	100 140		mV
6.13	VDD3/5_UVhead	VDD3/5 undervoltage headroom (VDD3/5act – VDD3/5_UVact)	VBATP = VBAT_SAFING	3.3-V setting 5-V setting	155 200		mV
6.14	VDD3/5_OV	VDD5_3 overvoltage level	VBATP = VBAT_SAFING	3.3-V setting 5-V setting	3.43 5.2	3.6 5.5	V
6.14a		Hysteresis	VBATP = VBAT_SAFING	3.3-V setting 5-V setting	100 140		mV
6.15	VDD3/5_UVhead	VDD3/5 undervoltage headroom (VDD3/5_OVact – VDD3/5act)	VBATP = VBAT_SAFING	3.3-V setting 5-V setting	170 200		mV
6.16	VDD1_UV	VDD1 undervoltage level	VBATP = VBAT_SAFING. Sensed on VDD1_SENSE pin. Relative thresholds are with respect to nominal 800-mV VDD1_SENSE (Pos 4.2)		752	784	mV
6.16a		Hysteresis	VBATP = VBAT_SAFING. Sensed on VDD1_SENSE pin. Relative thresholds are with respect to nominal 800-mV VDD1_SENSE (Pos 4.2)		10		mV
6.17	VDD1_OV	VDD1 overvoltage level	VBATP = VBAT_SAFING. Sensed on VDD1_SENSE pin. Relative thresholds are with respect to nominal 800-mV VDD1_SENSE (Pos 4.2)		816	848	mV
6.17a		Hysteresis	VBATP = VBAT_SAFING. Sensed on VDD1_SENSE pin. Relative thresholds are with respect to nominal 800-mV VDD1_SENSE (Pos 4.2)		9		mV
6.19	VSOUT1_UV	VSOUT1 undervoltage level	Sensed on VSFB1 pin. Relative thresholds (ratio) are: <ul style="list-style-type: none"> <li>For non-tracking mode, with respect to nominal 2.5-V VSFB1 (Pos 5.3)</li> <li>For tracking mode, with respect to voltage applied on VTRACK1 pin</li> <li>In tracking mode, VSOUT1_UV comparator output is valid for VTRACK1 DC condition</li> </ul>		0.88	0.94	VSOUT 1
6.20	VSOUT1_OV	VSOUT1 overvoltage level	Sensed on VSFB1 pin. Relative thresholds (ratio) are: <ul style="list-style-type: none"> <li>For non-tracking mode, with respect to nominal 2.5-V VSFB1 (Pos 5.3)</li> <li>For tracking mode, with respect to voltage applied on VTRACK1 pin</li> <li>In tracking mode, VSOUT1_OV comparator output is valid for VTRACK1 DC condition</li> </ul>		1.06	1.12	VSOUT 1
6.22	VDD6_UV	VDD6 undervoltage level <sup>(24)</sup>			5.2	5.4	V
6.22a		Hysteresis			115		mV
6.23	VDD6_OV	VDD6 overvoltage level <sup>(24)</sup>			7.8	8.2	V
6.23a		Hysteresis			115		mV
<b>IGNITION AND CAN WAKE-UP</b>							
7.1	IGN_WUP	IGN wake-up threshold <sup>(25)</sup>	VBATP = VBAT_SAFING = 12 V		2	3	V
7.2	CAN_WUP	CAN wake-up threshold <sup>(25)</sup>	VBATP = VBAT_SAFING = 12 V		2	3	V
7.3	WUP_hyst	Wake-up hysteresis	VBATP = VBAT_SAFING = 12 V		50	200	mV
7.4	I_IGN	IGN pin forward leakage current	IGN pin at 36 V, VBATP = VBAT_SAFING = 12V			50	μA
7.5	I_IGN_rev	IGN reverse current	IGN at -7 V, VBATP = VBAT_SAFING = 12 V		-1		mA
7.7	I_CANWU	CANWU pin forward leakage current	CANWU pin at 36 V, VBATP = VBAT_SAFING = 12V			50	μA
7.8	I_CAN_rev	CANWU reverse current	CANWU at -0.3 V, VBATP = VBAT_SAFING = 12 V				mA
<b>CHARGE PUMP</b>							
AN	C <sub>pump</sub>	Pumping capacitor (between CP1 and CP2)			10		nF
AN	C <sub>store</sub>	Storage capacitor (between VCP and VBATP)			100		nF
8.1	VCP <sub>on</sub>	VCP output voltage in on-state	VBATP > 5.8 V		VBATP + 4	VBATP + 15	V
8.2	I <sub>CP</sub>	External load	Load coming from R <sub>GS</sub> of Reverse Battery Protection			100	μA

(24) Information in SPI register only

(25) For device wake up, VBATP and VBAT\_SAFING must be operating range, Recommended Operating Conditions R1.1 and R1.3a, and then a level on either IGN or CANWU to allow the device to start up, especially when VBATP and VBAT\_SAFING are ramping.

## Electrical Characteristics *(continued)*

Over operating ambient temperature  $T_A = -40^{\circ}\text{C}$  to the maximum-operating junction temperature  $T_J = 150^{\circ}\text{C}$ , and with  $\text{VBATP} = \text{VBAT\_SAFING}$  in the recommended operating range (see R1.2 in [Section 4.3](#)) (unless otherwise noted)

POS	PARAMETER		TEST CONDITIONS	MIN	TYP	MAX	UNIT
8.3	$f_{CP}$	Charge-pump switching frequency		225	250	275	kHz
<b>RESET AND ENABLE OUTPUTS</b>							
9.1	$V_{NRES\_ENDRV\_L}$	NRES / ENDRV low-output level	With external 2-mA open-drain current			0.2	V
9.2	$R_{NRES\_ENDRV\_PULLUP}$	NRES / ENDRV internal pullup resistance		3		6	k $\Omega$
9.2a	$R_{DS(on)\_ENDRV\_NRES}$	$R_{DS(on)}$ NRES/ENDRV pulldown transistor				40	$\Omega$
9.3	$R_{RSTEXT}$	Value of external reset extension resistor, in case of open-connect, device stays in RESET state <sup>(26)</sup>		0	22		k $\Omega$
9.5	$V_{ENDRV\_NRES\_TH}$	ENDRV and NRES input readback <i>logic 1</i> threshold	Read-back muxed to DIAG_OUT pin	350	400	450	mV
<b>DIGITAL INPUT / OUTPUT</b>							
10.1	$V_{DIGIN\_HIGH}$	Digital input, high level for NCS, SDI, SCLK, ERROR/WDI and SEL_VDD3/5		2			V
10.2	$V_{DIGIN\_LOW}$	Digital input, low level for NCS, SDI, SCLK, ERROR/WDI and SEL_VDD3/5				0.8	V
10.3	$V_{DIGIN\_HYST}$	Digital input hysteresis for NCS, SCL, SCLK and ERROR/WDI <sup>(27)</sup>		0.1			V
10.4	$R_{DIAGOUT\_AMUX}$	Output resistance at DIAG_OUT pin in AMUX mode	BG1 selected on AMUX, < 200 nA current in or out of DIAG_OUT pin			15	k $\Omega$
10.5	$V_{DIGOUT\_HIGH}$	Digital output, high level <sup>(28)</sup>	$I_{OUT} = -2$ mA (out of pin)			VDDIO – 0.2	V
10.6	$V_{DIGOUT\_LOW}$	Digital output, low level <sup>(28)</sup>	$I_{OUT} = 2$ mA (into pin)			0.2	V
<b>SERIAL PERIPHERAL INTERFACE</b>							
13.12	$R_{PULL\_UP}$	Internal pullup resistor on NCS input pin		40	70	100	k $\Omega$
13.13	$R_{PULL\_DOWN}$	Internal pulldown resistor on SDI and SCLK input pins		40	70	100	k $\Omega$

(26) The maximum resistance recommend for RSTEXT to ground is 120 k $\Omega$ .

(27) SEL\_VDD3/5 is sampled and latched at device power up hysteresis,  $V_{DIGIN\_HYST}$ , does not apply.

(28) For pins SDO and DIAG\_OUT in DMUX mode.

## 4.6 Timing Requirements

Over operating ambient temperature  $T_A = -40^{\circ}\text{C}$  to the maximum-operating junction temperature  $T_J = 150^{\circ}\text{C}$ , and  $\text{VBATP} = \text{VBAT\_SAFING}$  in the recommended operating range (see R1.2 in the [Section 4.3](#)) (unless otherwise noted)

POS			MIN	NOM	MAX	UNIT	
<b>VDD5 – LDO WITH INTERNAL FET</b>							
2.12	$t_{delayVDD5}$	VDD5 voltage stabilization delay			5	ms	
<b>VDD3/5 – LDO WITH INTERNAL FET</b>							
3.12	$t_{VDD3/5}$	VDD3/5 voltage stabilization delay			5	ms	
<b>VDD1 – LDO WITH EXTERNAL FET</b>							
4.15	$t_{delayVDD1}$	VDD1 voltage stabilization delay			5	ms	
<b>VOLTAGE MONITORING</b>							
6.7	$VBATP\_deglitch$	VBATP undervoltage and overvoltage monitor deglitch time	180	240 <sup>(1)</sup>	260	$\mu\text{s}$	
6.18	$VDDx\_deglitch$	VDDx undervoltage and overvoltage monitor deglitch time	10		40	$\mu\text{s}$	
6.21	$VSOUT1\_deglitch$	VSOUT1 undervoltage and overvoltage monitor deglitch time	10		40	$\mu\text{s}$	
<b>IGNITION AND CAN WAKE-UP (IGN AND CANWU)</b>							
7.6	$IGN\_deg$	IGN deglitch filter time	7.5		22	ms	
7.9	$CANWU\_deg$	CANWU deglitch filter time	100		350	$\mu\text{s}$	
<b>RESET AND ENABLE OUTPUTS</b>							
9.4	$t_{RSTEXT(22k\Omega)}$	Reset extension delay	22 k $\Omega$	4.05	4.5	4.95	ms
9.4a	$t_{RSTEXT(0k\Omega)}$	Reset extension delay	0 k $\Omega$	0.98	1.4	1.89	ms
<b>INTERNAL SYSTEM CLOCK</b>							

(1) 240  $\mu\text{s}$  for VBAT-UV deglitch and 260  $\mu\text{s}$  for VBAT-OV deglitch

Timing Requirements (continued)

Over operating ambient temperature  $T_A = -40^{\circ}\text{C}$  to the maximum-operating junction temperature  $T_J = 150^{\circ}\text{C}$ , and  $\text{VBATP} = \text{VBAT\_SAFING}$  in the recommended operating range (see R1.2 in the Section 4.3) (unless otherwise noted)

POS	PARAMETER	TEST CONDITIONS	MIN	NOM	MAX	UNIT
11.1	$f_{\text{Sysclk}}$	System clock frequency <sup>(2)</sup>	3.8	4	4.2	MHz
<b>WINDOW WATCHDOG</b>						
12.2	$t_{\text{WD\_pulse}}$	Deglintch time on ERROR/WDI pin for watchdog-trigger input signal	14.25	30	32	$\mu\text{s}$
<b>SERIAL PERIPHERAL INTERFACE TIMING <sup>(3)</sup></b>						
13.1	$f_{\text{SPI}}$	SPI clock (SCLK) frequency	VDDIO = 3.3 V		5 <sup>(4)</sup>	MHz
			VDDIO = 5 V		6	
13.2	$t_{\text{SPI}}$	SPI clock period	VDDIO = 3.3 V		200	ns
			VDDIO = 5 V		167	
13.3	$t_{\text{high}}$	High time: SCLK logic high duration	See Figure 4-2		85.7	ns
13.4	$t_{\text{low}}$	Low time: SCLK logic low duration			45	ns
13.5	$t_{\text{sucs}}$	Setup time NCS: time between falling edge of NCS and rising edge of SCLK			45	ns
13.7	$t_{\text{susi}}$	Setup time at SDI: setup time of SDI before the falling edge of SCLK			15	ns
13.9	$t_{\text{hcs}}$	Hold time: time between the falling edge of SCLK and rising edge of NCS			45	ns
13.10	$t_{\text{hics}}$	SPI transfer inactive time (time between two transfers) during which NCS must remain high			788	ns

- (2) The system clock is also used to derive the clock for the watchdog timer, so the system clock tolerance also impacts the watchdog-timer tolerance.
- (3) Capacitance at  $C_{\text{SDO}} = 100 \text{ pF}$
- (4) MAX SPI Clock tolerance is  $\pm 10\%$

4.7 Switching Characteristics

Over operating ambient temperature  $T_A = -40^{\circ}\text{C}$  to the maximum-operating junction temperature  $T_J = 150^{\circ}\text{C}$ , and  $\text{VBATP} = \text{VBAT\_SAFING}$  in the recommended operating range (see R1.2 in Section 4.3) (unless otherwise noted)

POS	PARAMETER	TEST CONDITIONS	MIN	TYP	MAX	UNIT	
<b>Serial Peripheral Interface Timing <sup>(1)</sup></b>							
13.6	$t_{\text{d1}}$	Delay time: time delay from falling edge of NCS to SDO transitioning from tri-state to 0	See Figure 4-2		53.3	ns	
13.8	$t_{\text{d2}}$	Delay time: time delay from rising edge of SCLK to data valid at SDO			0	85.7	ns
13.11	$t_{\text{tri}}$	Tri-state delay time: time between rising edge of NCS and SDO in tri-state				53.3	ns

- (1) Capacitance at  $C_{\text{SDO}} = 100 \text{ pF}$

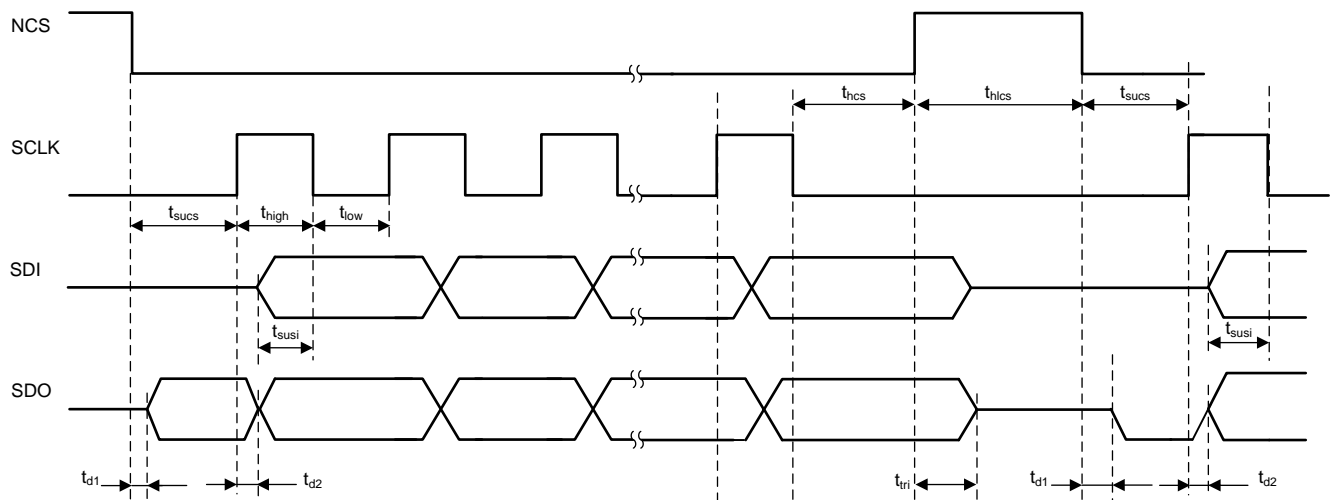

Figure 4-2. SPI Timing Parameters

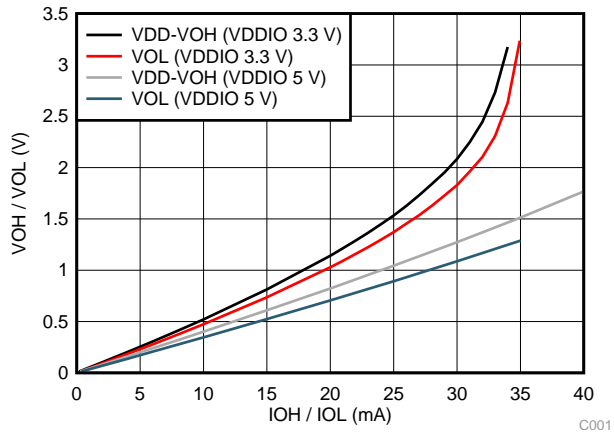

Figure 4-3. SPI SDO Buffer Source and Sink Current

4.8 Typical Characteristics

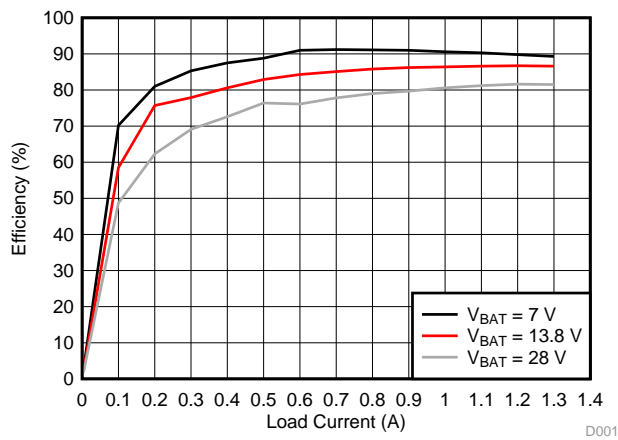

Figure 4-4. VDD6 BUCK Efficiency

## 5 Detailed Description

### 5.1 Overview

The device integrates an asynchronous-buck switch mode power-supply converter with an internal FET that converts the input battery voltage to a 6-V preregulator output, which supplies the integrated regulators.

A fixed 5-V linear regulator with an internal FET is integrated to be used as, for example, a CAN supply. A second linear regulator, also with an internal FET, regulates the 6 V to a selectable 5-V or 3.3-V MCU I/O voltage. A linear regulator controller with an external FET and resistor-divider regulates the 6 V to an externally adjustable core voltage of between 0.8 V and 3.3 V. A linear regulator with two different modes of operation (tracking mode and non-tracking mode) with adjustable voltage between 3.3 V and 9.5 V can be used as a supply for external sensor.

The device monitors undervoltage and overvoltage on all regulator outputs, battery voltage, and internal supply rails. A second band-gap reference, independent from the main band-gap reference used for regulation circuit, is used for undervoltage and overvoltage monitoring. In addition, regulator current-limits and temperature protections are implemented.

The device supports wakeup from IGNITION or wakeup from a CAN transceiver.

### 5.2 Functional Block Diagram

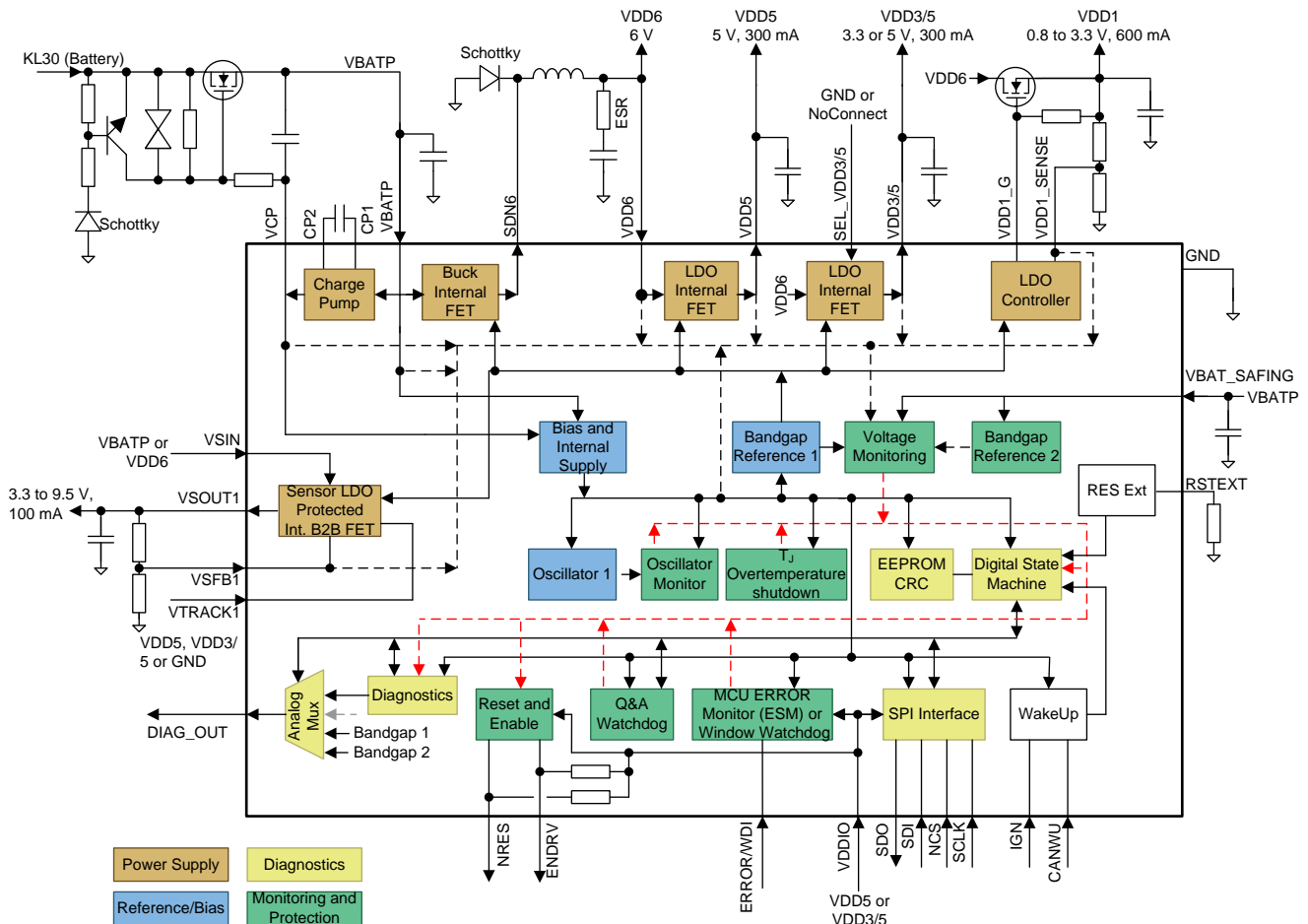

Copyright © 2017, Texas Instruments Incorporated

## 5.3 Feature Description

### 5.3.1 VDD6 Buck Switch-Mode Power Supply

The purpose of the VDD6 buck switch-mode power supply is to reduce the power dissipation inside the device as a preregulator. The VDD6 supply regulates from the battery voltage (main supply) range to 6 V. The VDD6 output is used as the input voltage for the VDD5, VDD3/5, VDD1, and can also be used for VSOUT1 regulator depending on the required VSOUT1 output voltage. The VDD6 supply is intended as a preregulator, therefore the output accuracy of VDD6 is less than the other integrated regulators. The VDD6 current capability is set to supply the VDD5, VDD3/5, VDD1, and VSOUT1 regulators at their respective maximum output currents. Power dissipation and thermal analysis should be performed to ensure the PCB design and thermal management can support the required power dissipation in the application.

This switch-mode power supply operates with fixed-frequency adaptive on-time control PWM. The control loop is based on a hysteretic comparator. The internal N-channel MOSFET is turned on at the beginning of each cycle if the sensed voltage on the VDD6 pin is below the hysteretic comparator threshold. When the MOSFET is turned on, it is on for a minimum of 7% duty cycle (7% of  $f_{\text{clk\_VDD6}}$ ). This MOSFET is turned off when the hysteretic comparator detects a voltage on the VDD6 pin above the threshold. The VDD6 regulator may skip pulses if the output voltage remains above the hysteretic comparator when the clock edge occurs. When the MOSFET is turned off, the external Schottky diode recirculates the energy stored in the inductor for the remainder of the switching period. The VDD6 regulator enters dropout mode (100% duty cycle) for a supply voltage below approximately 7 V on the VBATP pin.

The internal MOSFET is protected from excessive power dissipation by a current-limit circuit. The VDD6 regulator also shares an overtemperature protection circuit with the VDD3/5 regulator. When overtemperature is detected by this circuit, the device transitions to the STANDBY state (all regulators switched off).

Because the control loop of the VDD6 regulator is based on a hysteretic comparator, the effective capacitance on the output, and effective series resistance (ESR) of the output capacitance must be considered. The effective capacitance of the output capacitors at the operating voltage (6 V, DC bias derating), tolerance, temperature range, and lifetime must meet the effective capacitance range for VDD6 ( $C_{\text{VDD6}}$ ). The capacitor supplier should provide the necessary derating data to calculate the effective capacitance. The hysteretic comparator also requires a specified ESR to ensure balanced operation. Typically low-ESR ceramic capacitors are used for the output, so an external resistor is required to bring the total ESR into the specified ESR range for the  $C_{\text{VDD6}}$ . A general guideline to achieve balanced operation is  $R_{\text{ESR}} = L / (15 \times C_{\text{Effective}})$ . Using a higher-effective output capacitance allows for a lower ESR, which leads to lower-voltage ripple. Additionally, the inductance influences the system: using a lower inductance value allows for lower ESR, however, the peak inductor current will be higher.

### 5.3.2 VDD5 Linear Regulator

The VDD5 pin is a regulated supply of 5 V  $\pm 2\%$  overtemperature and battery supply range. A low-ESR ceramic capacitor is required for loop stabilization. This capacitor must be placed close to the pin of the device. This output is protected against shorts to ground by a current-limit. This output also limits output-voltage overshoot during power up and during line or load transients.

On an initial IGN or CANWU power cycle, the soft-start circuit on this regulator is initiated, which is typically from 1 ms to 2 ms. This output can require a larger output capacitor to ensure that during load transients the output does not drop below the required regulation specifications.

The internal MOSFET is protected from excess power dissipation with junction-overtemperature protection. In case of an overtemperature condition in the VDD5 pin, only the VDD5 regulator switches off by clearing bit D4 in the SENS\_CTRL register. To re-enable the VDD5 pin, bit D4 in the SENS\_CTRL register must be set again.

### 5.3.3 VDD3/5 Linear Regulator

The VDD3/5 pin is a regulated supply of 3.3 V or 5 V  $\pm 2\%$  overtemperature and battery supply range. The output voltage level is selected with the SEL\_VDD3/5 pin (open pin selects 3.3 V, grounded pin selects 5 V). The state of this selection pin is sampled and latched directly at the first initial IGN or CANWU power cycle. When latched, any change in the state of this selection pin after the first initial IGN or CANWU power cycle does not change the initially selected state of the VDD3/5 regulator.

A low-ESR ceramic capacitor is required for loop stabilization. This capacitor must be placed close to the pin of the device. This output is protected against shorts to ground by a current-limit. This output also limits output-voltage overshoot during power up or during line or load transients.

On an initial IGN or CANWU power cycle, the soft-start circuit on this regulator is initiated, which is typically from 1 ms to 2 ms. This output may require a larger output capacitor to ensure that during load transients the output does NOT drop below the required regulation specifications.

The internal MOSFET is protected from excess power dissipation with a current-limit circuit and junction overtemperature protection. In case of an overtemperature in the VDD3/5 pin, the TPS65381-Q1 device enters the STANDBY state (all regulators switched-off).

### 5.3.4 VDD1 Linear Regulator

The VDD1 pin is an adjustable regulated supply from 0.8 V to 3.3 V. This regulator uses a  $\pm 2\%$  reference (VDD1<sub>SENSE</sub>). The tolerance of the external feedback resistor divider resistors have an impact to the overall VDD1 regulation tolerance. To reduce on-chip power consumption, an external power NMOS is used. The regulation loop and the command gate drive are integrated. TI recommends applying a resistor with a value of 100 k $\Omega$  to 1 M $\Omega$  between the gate and source of the external power NMOS. The VDD1 gate output is limited to prevent gate-source overvoltage stress during power up or during line or load transients.

On an initial IGN or CANWU power cycle, the soft-start circuit on this regulator is initiated, which is typically from 1 ms to 2 ms. This soft-start is meant to prevent any voltage overshoot at start-up. The VDD1 output may require larger output capacitor to ensure that during load transients the output does not drop below the required regulation specifications.

The VDD1 LDO has no current-limit and no overtemperature protection for the external NMOS FET. Therefore, supplying the VDD1 pin from the VDD6 pin is recommended (see [Section 5.2](#)). In this way, the VDD6 pin current-limit acts as current-limit for the VDD1 pin and the power dissipation is limited also. To avoid damage in the external NMOS FET, selecting the current rating of the VDD1 pin well above the maximum-specified VDD6 current-limit is recommended.

If the VDD1 regulator is not used, leave the VDD1\_G and VDD1\_SENSE pins open. An internal pullup device on the VDD1\_SENSE pin detects the open connection and pulls up the VDD1\_SENSE pin. This forces the regulation loop to bring the VDD1\_G output down. This mechanism also masks the VDD1\_OV flag in VMON\_STAT\_2 register and therefore the ENDRV pin action from a VDD1 overvoltage (OV) condition is also masked. These actions are equivalent to clearing the NMASK\_VDD1\_UV\_OV bit in the DEV\_CFG1 register to 0. This internal pullup device on the VDD1\_SENSE pin also prevents a real VDD1 overvoltage on the MCU core supply in case of an open connection to the VDD1\_SENSE pin, as it brings the VDD1\_G pin down. Therefore, in this situation, the VDD1 output voltage is 0 V.

By default, VDD1 monitoring is disabled. If the VDD1 pin is used in the application, TI recommends to set the NMASK\_VDD1\_UV\_OV bit in the DEV\_CFG1 register to 1 when the device is in the DIAGNOSTIC state. This setting enables driving and extending the reset to the external MCU when a VDD1 undervoltage event is detected.

### 5.3.5 VSOUT1 Linear Regulator

The VSOUT1 regulator is a regulated supply with two separate modes: tracking mode and non-tracking mode. The mode selection occurs with the VTRACK1 pin. When the voltage applied on the VTRACK1 pin is above 1.2 V, the VSOUT1 pin is in tracking mode. When the VTRACK1 pin is shorted to ground, the VSOUT1 regulator is in non-tracking mode. This mode selection occurs during the first ramp-up of the VDDx rails and is latched after the first VDDx ramp-up is complete. Therefore, after completion of the VDDx ramp-up, any change on the VTRACK1 pin no longer affects the selected tracking or non-tracking mode.

In tracking mode, the VSOUT1 regulator tracks the input reference voltage on the VTRACK1 pin with a gain factor determined by the external resistive divider. The tracking offset between the VTRACK1 and VSFB1 pins is  $\pm 35$  mV. This mode allows, for instance, the VSOUT1 output voltage to be 5 V while tracking the VDD3 (3.3-V) supply. In unity-gain feedback, the VSOUT1 output voltage can directly follow the VDD5 pin or the VDD3 pin.

In non-tracking mode, the VSOUT1 output voltage is proportional to a fixed reference voltage of 2.5 V at the VSFB1 pin, with a gain factor determined by the external resistive divider. This mode allows the VSOUT1 pin to be any factor of the internal reference voltage.

Both in tracking and non-tracking mode, the VSOUT1 output voltage must be 3.3 V or higher. The VSOUT1 regulator can track the VDD3/5 pin in 3.3-V setting within the specified limits.

The VSOUT1 regulator has a separate input supply to reduce the internal power dissipation. For an output voltage of 3.3 V or 5 V, for instance, the VDD6 supply can be used as the input supply. For an output voltage greater than 5 V, the VBATP pin can be used as the input supply. The maximum power dissipation for the internal FET must not exceed 0.6 W to avoid overtemperature (thermal shutdown).

A low-ESR ceramic capacitor is required for loop stabilization; this capacitor must be placed close to the pin of the device. This supply limits output-voltage overshoot during power up or during line or load transients.

This supply rail is intended for going outside the ECU and therefore is protected against shorts to external chassis ground by a current-limit. The supply rail can be shorted externally within the specified short circuit voltages, VSOUT1<sub>SH</sub>. If the output can be shorted to voltages outside the specified short circuit voltage range, additional external protection is required.

The VSOUT1 regulator is disabled by default on start-up. After the NRES pin release, the MCU can enable the VSOUT1 regulator through a SPI command by setting bit D0 in the SENS\_CTRL register. After this SPI command, the soft-start circuit on this regulator is initiated, which is typically from 1 ms to 2 ms. This output may require a larger output capacitor to ensure that during load transients the output does NOT drop below the required regulation specifications. Regardless of tracking or non-tracking mode, the VSFB1 pin is ramped to the desired value after completion of the soft start.

The internal MOSFET is protected from excess power dissipation with a current-limit circuit and junction-temperature protection. In case of an overtemperature condition in the VSOUT1 pin, only the VSOUT1 regulator is switched off by clearing bit 0 in the SENS\_CTRL register. To re-enable the VSOUT1 pin, first bit 2 in the SAFETY\_STAT 1 register must be cleared on read-out, and afterwards bit 0 in the SENS\_CTRL register must be set again.

The VSOUT1 pin voltage can be observed by the ADC input of the MCU through the DIAG\_OUT pin (see [Section 5.4.9](#)), which allows the detection of a short to any other supply prior to enabling the VSOUT1 LDO.

---

**NOTE**

The VSOUT1\_EN bit is in the SENS\_CTRL register which is only reinitialized by a power-on reset (NPOR) event and not a transition through the RESET state. If the VSOUT1\_EN bit was previously set to 1, it remains set to 1 and the VSOUT1 regulator remains enabled after events that cause a transition to the RESET state. In a fault case that would cause an undervoltage or overvoltage on the VSOUT1 pin, when a BIST runs automatically on the transition from the RESET to the DIAGNOSTIC state, the VSOUT1\_UV or VSOUT1\_OV condition during the BIST run would cause the device to go to the SAFE state because of the detected ABIST\_ERR.

---

### 5.3.6 Charge Pump

The charge pump is used to generate an overdrive voltage from the VBATP supply that is used for driving the gates of the internal NMOS FETs in the VDDx and VSOUT1 supply rails. The charge pump is a hysteretic architecture, when the VCP voltage is high enough, the CP\_OV bit sets and the charge pump stops pumping until the VCP voltage drops below the threshold, the CP\_OV bit clears and the charge pump starts pumping again. The charge pump overdrive is provided internally to the device through the linear regulators, VCP12 and VCP17. Furthermore, this overdrive voltage can drive the gate of an external NMOS FET acting as reverse-battery protection. Such reverse-battery protection allows for lower battery voltage operation compared to a traditional reverse battery-blocking diode. When using the charge pump (VCP) to drive the gate of an NMOS for reverse battery protection, a series resistance of about 10 kΩ must be connected between the VCP pin and the gate of the NMOS FET (see [Section 5.2](#)). This series resistance is required to limit any current out of the VCP pin when the gate of the NMOS FET is driven to a negative voltage, because the absolute maximum rating of the VCP pin is limited to –0.3 V because of a parasitic reverse diode to the substrate (ground).

The charge pump requires two external capacitors, one pumping capacitor ( $C_{\text{pump}}$ ) and one storage capacitor ( $C_{\text{store}}$ ). To have sufficient overdrive voltage out of the charge pump even at low battery voltage, the external load current on the VCP pin must be less than 100 μA.

### 5.3.7 Wake-Up

The TPS65381-Q1 device has two wake-up pins: IGN and CANWU. Both pins have a wake-up threshold level from 2 V to 3 V, and a hysteresis from 50 mV to 200 mV.

The IGN wake-up pin is level-sensitive and is deglitched with the IGN\_deg deglitch (filter) time. The TPS65381-Q1 device provides a power-latch function (POST\_RUN) for this IGN pin, allowing the MCU to decide when to power down the TPS65381-Q1 device through SPI command. For this, the MCU must set the IGN power-latch bit 4 (IGN\_PWRL) in the SPI SAFETY\_FUNC\_CFG register, and read the unlatched status of the deglitched (filtered) IGN pin on the SPI register, DEV\_STAT, bit 0 (IGN). To enter the STANDBY state, the MCU must clear the IGN\_PWRL bit. For this, the TPS65381-Q1 device must be in the DIAGNOSTIC state because this SPI register is only writable in the DIAGNOSTIC state. The IGN\_PWRL bit is also cleared after a detected CANWU wake-up event. Furthermore, the TPS65381-Q1 device provides an optional transition to the RESET state after a detected IGN wake-up during POST\_RUN (see [Figure 5-2](#)).

The CANWU pin is level sensitive and is deglitched with CANWU\_deg (filter) time. The deglitched (filtered) CANWU wake-up signal is latched, into CANWU\_L, allowing the MCU to decide when to power down the TPS65381-Q1 device through the WR\_CAN\_STBY SPI command.

---

**NOTE**

The WR\_CAN\_STBY command should not be written to the device while the CANWU pin or IGN pin is still high. The device starts to transition to the STANDBY state and immediately transitions to the RESET state because of the wake-up request received on the CANWU or IGN pin. The registers are reinitialization according to post LBIST (because of a RESET transition) or according to NPOR (because of a STANDBY transition).

---

Both the IGN and CANWU pins are high voltage pins. If the pins are connected to lines with transients, the application should provide proper filtering and protection to ensure the pins stay within the specified voltage range.

---

**NOTE**

If the application does not require wake up from IGN (ignition or KL15) or wake up from CANWU (a CAN or other transceiver), but the device should wake up any time power is supplied, one method is to connect the IGN pin to the VBATP pin (and VBAT\_SAFING) through a 10-k $\Omega$  or greater series resistor. When the VBATP supply is turned on, the IGN pin also goes high and allows the device to wake up (power up) as soon as the voltage levels allow the release of NPOR circuits for the VBATP and VBAT\_SAFING pins, and the IGN pin is high.

---

### **5.3.8 Reset Extension**

During a power-up event, the TPS65381-Q1 device releases the reset to the external MCU through the NRES pin with a certain delay time (reset extension time) after the VDD3/5 and VDD1 pins have crossed the respective undervoltage thresholds.

This reset extension time is externally configurable with a resistor between the RESEXT pin and ground. When shorting the RESEXT pin to ground, the minimum reset extension time is typically 1.4 ms. For a 22-k $\Omega$  external resistor, the typical reset extension time is 4.5 ms.

## 5.4 Device Functional Modes

### 5.4.1 Power-Up and Power-Down Behavior

Figure 5-1 shows the power-up and power-down behavior.

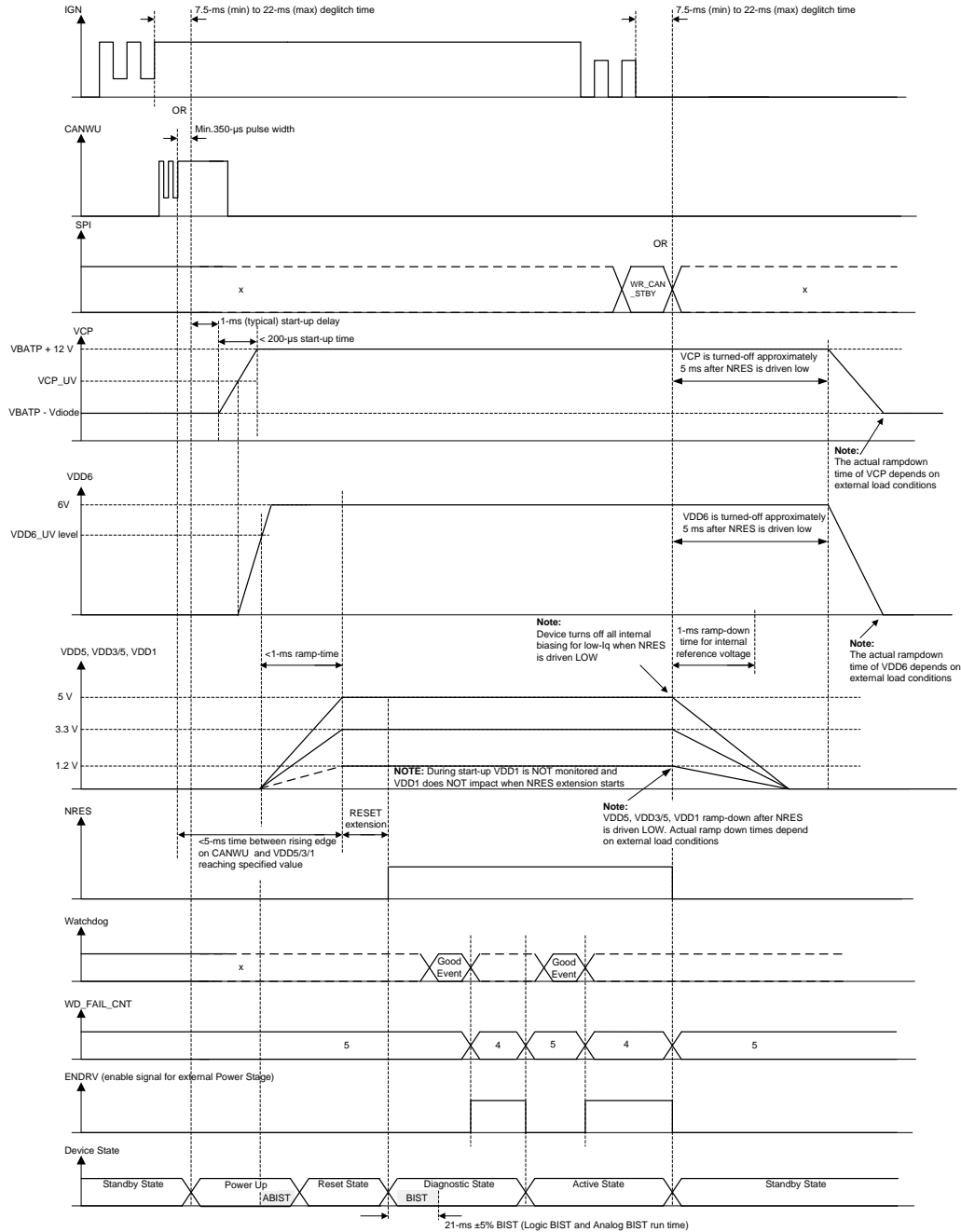

- (1) During a power-up event, the analog BIST (ABIST) begins automatically after the VDD6 rail ramps above the UV threshold. If the ABIST fails, the device transitions to the SAFE state.
- (2) The device may not be able to respond to MCU SPI communication during a BIST, so if the MCU boots faster than the BIST, it should wait until the BIST is complete to use SPI communication. If the ABIST, LBIST, or both fail, the device transitions to the SAFE state.
- (3) The level of the ENDRV pin depends on the watchdog failure counter, WD\_FAIL\_CNT[2:0], the ENABLE\_DRV bit, and the signals shown in Figure 5-14.

The MCU should only set the ENABLE\_DRV bit when the WD\_FAIL\_CNT[2:0] counter is below 5.

Figure 5-1. Power-Up and Power-Down Behavior

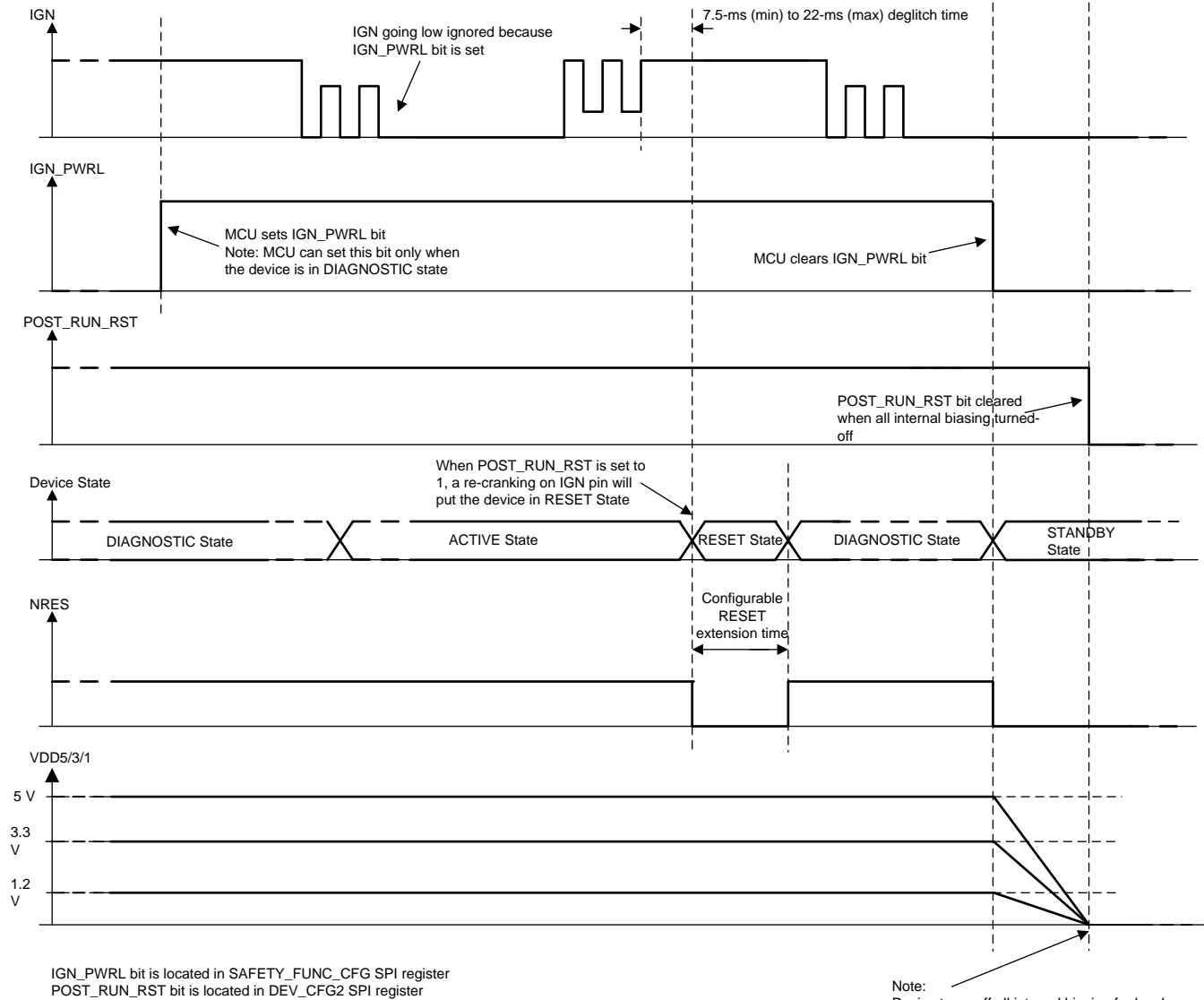

- (1) Under slow VBAT ramp-down and when the VDD3/5 rail is configured as a 5-V rail, the NRES output can be pulled low when VBAT is at approximately 6.3 V. This occurs because of an undervoltage transient on VDD3/5 rail.
- (2) Under slow VBAT ramp-up and when the VDD3/5 rail is configured as a 5-V rail, the NRES output can be pulled low when VBAT is at approximately 6.6 V. This occurs because of an undervoltage transient on VDD3/5 rail.
- (3) Under similar conditions, undervoltage transients are observed on VDD5 and VSOUT1 rails.

Figure 5-2. IGN Power Latch and POST-RUN Reset

### 5.4.2 Safety Functions and Diagnostics Overview

The TPS65381-Q1 device is intended for use in automotive and industrial safety-relevant applications. The following list of monitoring and protection blocks are those that improve the diagnostic coverage and decrease the undetected fault rate:

- Voltage monitor (VMON)
- Analog built-in self-test (ABIST) diagnostics for safety analog blocks
- Logic built-in self-test (LBIST) for safety controller functions
- Loss-of-clock monitor (LCMON)
- Junction temperature monitoring for all power supplies with internal FET
- Current-limit for all power supplies
- Analog MUX (AMUX) for externally monitored diagnostics and debug
- Digital MUX (DMUX) for externally monitored diagnostics and debug
- Watchdog configurable for trigger mode (open and close window) or question and answer mode
- MCU error signal monitor (ESM) for monitoring the error output from functional safety architecture MCUs
- Controlled and protected enable output (ENDRV) for external power stages or peripheral wakeup
- Device configuration register CRC protection
- SPI command decoder with parity check
- SPI data output feedback check
- Reset circuit for initializing external MCU
- EEPROM analog trim content CRC protection
- Device state controller with SAFE state in case of detected error event

### 5.4.3 Voltage Monitor (VMON)

The VBAT supply voltage, all regulator outputs, and internally generated voltages are supervised by a voltage monitor module (VMON). An undervoltage or overvoltage condition is indicated by the corresponding VMON register status flag bits:

- VMON flag bit cleared to 0 when power supply is within specification
- VMON flag bit set to 1 when power supply is outside tolerance band

The monitoring occurs by undervoltage and overvoltage comparators. The reference voltage (BANDGAP\_REF2) for the VMON module is independent of the system reference voltage (BANDGAP\_REF1) used by the regulators. A glitch-filtering function ensures reliable monitoring without false setting of the VMON status flag bits. The complete VMON block is supplied by a separate supply pin, VBAT\_SAFING.

The VMON comparator diagnostics are covered by the ABIST executed during device startup and power up or activated with the SPI command by the external MCU SPI request when the device is in the DIAGNOSTIC or ACTIVE state. Each monitored voltage rail is emulated for undervoltage and overvoltage conditions on the corresponding comparator inputs, therefore forcing the corresponding comparator to toggle multiple times (in a toggling pattern observed and checked by the ABIST controller). The monitored voltage rails themselves are not affected during this self-test, so no real undervoltage or overvoltage event occurs on any of these rails because of this self-test.

[Table 5-1](#) lists an overview of the performed voltage monitoring. As listed in this table, an overvoltage protection is implemented for some of the internal supply rails.

**Table 5-1. Voltage Monitoring Overview<sup>(1)</sup>**

VOLTAGE RAIL	OUTPUT VOLTAGE	CREATED FROM REFERENCE	MONITORING DETECTION THRESHOLDS		MONITORED AGAINST REFERENCE	MONITORED PIN	OV PROTECTION LEVEL	OV PROTECTION REFERENCE	IMPACT ON DEVICE BEHAVIOR	
			UV	OV					UV	OV
<b>SUPPLY INPUT</b>										
VBAT	N/A	N/A	4.2 to 4.5 V	34.7 to 36.7 V	VMON_BG	VBATP	N/A	N/A	SPI flag VMON_STAT_1 D6 STANDBY state NRES = 0, ENDRV = 0	SPI flag VMON_STAT_1 D7 RESET state (when MASK_VBATP_OV = 0)
<b>SUPPLY OUTPUTS</b>										
VDD6	6 V ± 10%	MAIN_BG	5.2 to 5.4 V	7.8 to 8.2 V	VMON_BG	VDD6	N/A	N/A	SPI flag VMON_STAT_2 D6	SPI flag VMON_STAT_2 D7
VDD5	5 V ± 2%	MAIN_BG	4.5 to 4.85 V	5.2 to 5.45 V	VMON_BG	VDD5	N/A	N/A	SPI flag VMON_STAT_2 D4	SPI flag VMON_STAT_2 D5 ENDRV = 0
VDD3/5 (5 V)	5 V ± 2%	MAIN_BG	4.5 to 4.85 V	5.2 to 5.5 V	VMON_BG	VDD3/5	N/A	N/A	SPI flag VMON_STAT_2 D2 RESET state NRES = 0, ENDRV = 0	SPI flag VMON_STAT_2 D3 ENDRV = 0
VDD3/5 (3.3 V)	3.3 V ± 2%		3 to 3.17 V	3.43 to 3.6 V						
VDD1	0.8 V to 3.3 V –1% to +2% VDD1_SENSE = 800 mV –1% to +2%	MAIN_BG	0.94 to 0.98 × VDD1	1.03 to 1.06 × VDD1	VMON_BG	VDD1_SENSE	N/A	N/A	SPI flag VMON_STAT_2 D0 RESET state NRES = 0, ENDRV = 0 (when NMASK_VDD1_UV_OV=1)	SPI flag VMON_STAT_2 D1 ENDRV = 0 (when NMASK_VDD1_UV_OV=1)
VSOUT1 (non-tracking)	3.3 V to 9.5 V ± 2% VDSFB1 = 2.5 V ± 2%	MAIN_BG	0.88 to 0.94 × VSOUT1	1.06 to 1.12 × VSOUT1	MAIN_BG	VSFB1	N/A	N/A	SAFETY_STAT1 D5	SPI flag SAFETY_STAT1 D4
VSOUT1 (tracking)	3.3 V to 9.5 V ± 2% VDSFB1 = VTRACK1 ± 20 mV	VTRACK1			VTRACK1	VSFB1	N/A	N/A		
<b>INTERNAL SUPPLIES</b>										
VCP17	17 V (typ)	MAIN_BG	N/A	27 V (typ)	VMON_BG	N/A	27 V (typ)	VMON_BG	N/A	SPI flag VMON_STAT_1 D5 → STANDBY state NRES = 0, ENDRV = 0
VCP12	12 V (typ)	MAIN_BG	7.43 V (typ)	14.2 V (typ)	VMON_BG	N/A	14.2 V (typ)	VMON_BG	SPI flag VMON_STAT_1 D3	SPI flag VMON_STAT_1 D4 VDD5, VDD3/5 and VDD1 not operational → STANDBY state NRES = 0, ENDRV = 0
AVDD	6.9 V (typ)	Internal LV Zener	3.6 V (typ)	N/A	Independent local band gap	N/A	NA	Internal MV Zener	NPOR → STANDBY state NRES = 0, ENDRV = 0	No Change
AVDD_VMON	6.9 V (typ)	Internal LV Zener	3.56 V (typ)	N/A	Independent local band gap	Indirectly monitoring VBAT_SAFING	< 10.48 V	Internal MV Zener	SPI flag VMON_STAT_1 D2 → NPOR → STANDBY state NRES = 0, ENDRV = 0	SPI flag VMON_STAT_1 D2 → NPOR → STANDBY state NRES = 0, ENDRV = 0
DVDD	3 V (typ)	MAIN_BG	2.472 V (typ)	3.501 V (typ)	VMON_BG	N/A	N/A	N/A	NPOR → STANDBY state NRES = 0, ENDRV = 0	NPOR → STANDBY state NRES = 0, ENDRV = 0
<b>INTERNAL REFERENCES</b>										
MAIN_BG	2.5 V ± 2%	MAIN_BG	2.364 V (typ)	2.617 V (typ)	VMON_BG	N/A	N/A	N/A	STANDBY state NRES = 0, ENDRV = 0	STANDBY state NRES = 0, ENDRV = 0
VMON_BG	2.5 V ± 2%	VMON_BG	2.364 V (typ)	2.617 V (typ)	MAIN_BG	N/A	N/A	N/A	STANDBY state NRES = 0, ENDRV = 0	STANDBY state NRES = 0, ENDRV = 0

(1) N/A = Not applicable

### 5.4.4 TPS65381-Q1 Internal Error Signals

Table 5-2 lists a useful overview of the TPS65381-Q1 device internal error signals and the impact of the signals on the device behavior.

**Table 5-2. Internal Error Signals**

DMUX POS. NO.	SIGNAL NAME	DESCRIPTION	DETECTIVE CONDITION (THRESHOLD LEVEL)					DEGLITCH TIME TO SET FLAG (μs)				DEVICE STATE WHEN FLAG IS SET		
			MIN	TYP	MAX	UNIT	ELEC. CHAR. NO.	MIN	TYP	MAX	ELEC. CHAR. NO.	NRES	ENDRV	DEVICE STATE
D1.2	NAVDD_UV	AVDD undervoltage comparator output (inverted)		3.6		V		15		30		LOW	LOW	STANDBY
D1.3	BG_ERR1	VMON or main band gap is OFF (set to 1 when VMON band gap > main band gap)		Main band gap = 2.364 (VMON band gap = 2.477)		V		15		30		LOW	LOW	STANDBY
D1.4	BG_ERR2	VMON or main band gap is OFF (set to 1 when VMON band gap < main band gap)		Main band gap = 2.617 (VMON band gap = 2.477)		V		15		30		LOW	LOW	STANDBY
D1.5	NVCP12_UV	VCP12 charge pump undervoltage comparator (inverted)		7.43		V		15		30		Not changed	Not changed	Not changed
D1.6	VCP12_OV	VCP12 charge-pump overvoltage comparator		14.2		V		15		30		LOW	LOW	STANDBY
D1.7	VCP17_OV	VCP17 charge-pump overvoltage comparator		21		V		15		30		LOW	LOW	STANDBY
D1.8	NVDD6_UV	VDD6 undervoltage comparator (inverted)	5.2		5.4	V	6.22	10		40	6.18	Not changed	Not changed	Not changed
D1.9	VDD6_OV	VDD6 overvoltage comparator	7.8		8.2	V	6.23	10		40	6.18	Not changed	Not changed	Not changed
D1.10	NVDD5_UV	VDD5 undervoltage comparator (inverted)	4.5		4.85	V	6.8	10		40	6.18	Not changed	Not changed	Not changed
D1.11	VDD5_OV	VDD5 overvoltage comparator	5.2		5.45	V	6.10	10		40	6.18	Not changed	LOW	Not changed
D1.12	NVDD3/5_UV	VDD3/5 undervoltage comparator; 3.3-V setting (inverted)	3		3.17	V	6.12	10		40	6.18	LOW	LOW	RESET
		VDD3/5 undervoltage comparator; 5-V setting (inverted)	4.5		4.85									
D1.13	VDD3/5_OV	VDD3/5 overvoltage comparator; 3.3-V setting	3.43		3.6	V	6.14	10		40	6.18	Not changed	LOW	Not changed
		VDD3/5 overvoltage comparator; 5-V setting	5.2		5.5									
D1.14	NVDD1_UV	VDD1 undervoltage comparator (inverted)	0.94		0.98	VDD1	6.16	10		40	6.18	Not changed when NMASK_VDD1_UV_OV = 0 (default config) When NMASK_VDD1_UV_OV = 1: NRES = LOW	Not changed when NMASK_VDD1_UV_OV = 0 (default config) When NMASK_VDD1_UV_OV = 1: ENDRV = LOW	Not changed when NMASK_VDD1_UV_OV = 0 (default config) When NMASK_VDD1_UV_OV = 1: RESET
D1.15	VDD1_OV	VDD1 overvoltage comparator	1.03		1.06	VDD1	6.17	10		40	6.18	Not changed	Not changed (default config) When MASK_VDD1_UV_OV = 1: ENDRV = LOW	Not changed

**Table 5-2. Internal Error Signals (continued)**

DETECTIVE CONDITION (THRESHOLD LEVEL)								DEGLITCH TIME TO SET FLAG (µs)				DEVICE STATE WHEN FLAG IS SET			
DMUX POS. NO.	SIGNAL NAME	DESCRIPTION	MIN	TYP	MAX	UNIT	ELEC. CHAR. NO.	MIN	TYP	MAX	ELEC. CHAR. NO.	NRES	ENDRV	DEVICE STATE	
D1.16	LOCLK	Loss-of-system-clock comparator	0.742		2.64	MHz		0.379		1.346		LOW	LOW	STANDBY	
D3.4	CP_OV	Charge-pump overvoltage comparator		VBAT + 12		V		N/A	N/A	N/A		Not changed	Not changed	Not changed	
D3.5	NCP_UV	Charge-pump undervoltage comparator (inverted)		VBAT + 6		V		N/A	N/A	N/A		Not changed	Not changed	Not changed	
D3.8	CP_DIFF3V	Indicates VCP-VBATP > 3 V		VBAT + 3		V		N/A	N/A	N/A		Not changed	Not changed	Not changed	
D3.10	NVBAT_UV	VBAT undervoltage comparator (inverted)	4.2		4.5	V	6.1		200		6.7	LOW	LOW	STANDBY	
D3.11	VBATP_OV	VBAT overvoltage comparator	34.7		36.7	V	6.5		200		6.7	LOW (default config) When MASK_VBATP_OV = 1: NRES unchanged	LOW (default config) When MASK_VBATP_OV = 1: ENDRV unchanged	RESET (default config) When MASK_VBATP_OV = 1: device state unchanged	
D3.12	VDD5_OT	VDD5 overtemperature	175		210	°C	3.13	45		64		LOW	LOW	Device state depends on NMASK_VDD5_OT bit setting: NMASK_VDD5_OT = 0 : no impact to device state NMASK_VDD5_OT = 1 : VDD5 disabled → RESET	
D3.13	VDD3/5_OT	VDD3/5 overtemperature	175		210	°C	2.13	45		64		LOW	LOW	Device state depends on NMASK_VDD3/5_OT bit setting: NMASK_VDD3/5_OT = 0 : VDD3/5 disabled → VDD3/5 UV event → RESET NMASK_VDD3/5_OT = 1 : STANDBY	
D3.14	VSOUT1_OT	VSOUT1 overtemperature	175		210	°C	5.13	45		64		Not changed	Not changed	Not changed	
D3.15	VDD5_CL	VDD5 current-limit <sup>(1)</sup>	350		650	mA	2.14	15		30		Not changed	Not changed	Not changed	
D3.16	VDD3/5_CL	VDD3/5 current-limit	350		650	mA	3.14	15		30		Not changed	Not changed	Not changed	
D4.2	VSOUT1_CL	VSOUT1 current-limit	100		500	mA	5.19	15		30		Not changed	Not changed	Not changed	
D4.3	NVSOUT1_UV	VSOUT1 undervoltage comparator (inverted)	0.88		0.94	VSOUT1	6.19	10		40	6.21	Not changed	Not changed	Not changed	
D4.4	VSOUT1_OV	VSOUT1 overvoltage comparator	1.06		1.12	VSOUT1	6.20	10		40	6.21	Not changed	Not changed	Not changed	
D4.5	NDVDD_UV	DVDD undervoltage comparator (inverted)		2.472		V			0			LOW	LOW	STANDBY	
D4.6	DVDD_OV	DVDD overvoltage comparator		3.501		V			0			LOW	LOW	STANDBY	
D4.8	VS_TRK_MODE	VSOUT1 in track-mode indication		1.2		V	5.3a	N/A	N/A	N/A		Not changed	Not changed	Not changed	
D4.9	VMON_TRIM_ERR	VMON trim error	Set when bit-flip in VMON trim registers is detected						5		10		LOW	LOW	STANDBY

(1) VDD5\_CL DMUX output is valid only when VDD5\_EN bit in SENS\_CTRL register is set to 1. When VDD5\_EN is cleared to 0, this VDD5\_CL will be high.

#### 5.4.5 Loss-of-Clock Monitor (LCMON)

The LCMON detects internal oscillator failures including:

- Oscillator clock stuck high or stuck low
- Reduced clock frequency

The LCMON is enabled during a power-up event after the power-on reset (NPOR) is released. The clock monitor remains active during device normal operation (STANDBY, RESET, DIAGNOSTIC, ACTIVE, and SAFE states). In case of a clock failure:

- The device transitions to the STANDBY state.
- All regulators are disabled.
- The digital core is reinitialized.
- The reset to the external MCU is asserted low.
- The failure condition is indicated by the LOCLK bit in the SAFETY\_STAT\_4 register.

The LCMON has a self-test structure that is activated and monitored by an analog BIST (ABIST). The external MCU can recheck the LCMON any time when the device is in the DIAGNOSTIC state or ACTIVE state. The enabled diagnostics emulate a clock failure that causes the clock-monitor output to toggle. The clock-monitor toggling pattern is checked by the ABIST, while the external MCU can check that the loss-of-clock status bit is being set during active test. During this self-test, the actual oscillator frequency (4 MHz) is not changed because of this self-test.

#### 5.4.6 Analog Built-In Self-Test (ABIST)

The ABIST is the controller and monitor circuit for performing self-checking diagnostics on critical analog functions:

- VMON undervoltage and overvoltage comparators
- Clock monitor (LCMON)
- EEPROM analog-trim content check (CRC protection)

During the self-test on the VMON undervoltage and overvoltage comparators, the monitored voltage rails are left unchanged, so no real undervoltage or overvoltage event occurs on any of these rails because of these self-tests. Furthermore, also during the self-check on the clock monitor, the actual oscillator frequency (4 MHz) is not changed because of this self-test.

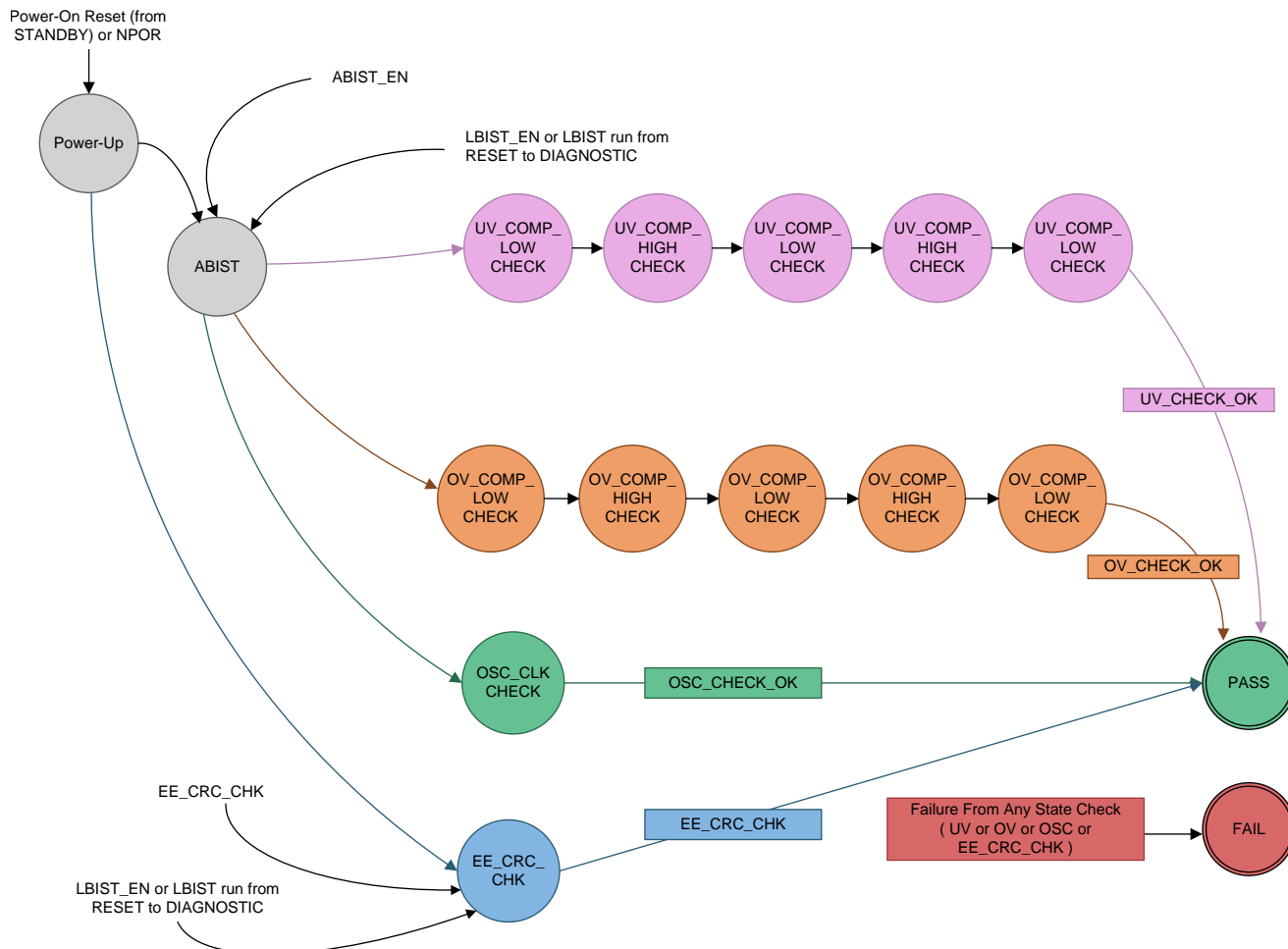

(1) For impact to the device state if any ABIST function has a FAIL, see [Section 5.4.19](#).

**Figure 5-3. Analog BIST Run States**

The ABIST is activated with every device power-up event or any transition to the RESET state. The ABIST can also be run by the external MCU by setting the ABIST\_EN bit in the SAFETY\_BIST\_CTRL register. During an ABIST run, the device cannot monitor the state of the regulated supplies, and the ENDRV pin is pulled low. The ABIST run time is approximately 300 μs. The ABIST can be performed in the ACTIVE state on an MCU request, depending on system safety requirements (such as a system-fault response time), ENDRV pin will be low during ABIST run.

A running ABIST is indicated in the ABIST\_RUN bit (bit D0) in the SAFETY\_STAT\_3 register. This bit is set to 1 during the ABIST run and is cleared to 0 when the ABIST is complete. In case of an ABIST failure while in the DIAGNOSTIC state, including power-up event, the device enters the SAFE state without asserting a reset to the external MCU and the ABIST\_ERR status flag remains latched in the digital core until a successful ABIST run. This allows the external MCU to detect the ABIST failure by reading the ABIST\_ERR bits in the SAFETY\_STAT\_3 register. In case of an ABIST failure while in the ACTIVE state, the device sets the ABIST\_ERR status flag, but no state transition occurs.

### 5.4.7 Logic Built-In Self-Test (LBIST)

The logic BIST (LBIST) tests the digital-core safety functions. The LBIST has these characteristics:

- An application-controllable logic BIST engine, which applies test vectors to the digital core.
- The LBIST engine provides stuck-at fault test coverage to logic blocks under test.
- The LBIST run time is typically 4.2 ms ( $\pm 5\%$ ). After the LBIST, a 16-ms (typical) wait period occurs to fill the digital filters covered by the LBIST. During this time, the ABIST runs. The total BIST time is approximately 21 ms. The SPI registers may be unavailable during a BIST, so no SPI reads or writes should be made while the BIST is running.
- The LBIST engine has a time-out counter as a fail-safe feature.

The BIST (LBIST with ABIST) is activated and run in the DIAGNOSTIC state with any transition out of the RESET state during power-up events. The BIST is also activated with any other transition out of the RESET state unless the AUTO\_BIST\_DIS bit in the SAFETY\_BIST\_CTRL register is set.

The MCU can run the LBIST (BIST) by setting the LBIST\_EN bit in the SAFETY\_BIST\_CTRL register.

---

#### NOTE

In the ACTIVE state the following considerations must be considered if a manual run of the LBIST is initiated by setting the LBIST\_EN bit to 1. The LBIST should only be run in the ACTIVE state if the system-safety timing requirements can allow the total 21-ms BIST time and ENDRV being low for the 21-ms time.

---



---

#### NOTE

In the ACTIVE or DIAGNOSTIC or SAFE state the following considerations must be considered if a manual run of the LBIST is initiated by setting the LBIST\_EN bit to 1. After the LBIST is complete the WD\_FAIL\_CNT[2:0] counter is re-initialized to 5. The MCU should resynchronize to the TPS65381-Q1 watchdog by writing to the WD\_WIN1\_CFG or WD\_WIN2\_CFG register or by immediately causing a bad event. Both of these resynchronization options start a new watchdog sequence and increment the WD\_FAIL\_CNT[2:0] counter. If the WD\_RST\_EN bit is set to 1 (enabled), the watchdog service routine in the MCU must ensure good events are sent to the watchdog to start decrementing the WD\_FAIL\_CNT[2:0] counter before it reaches 7 +1 which cause a transition to the RESET state. After the LBIST is complete some of the registers are reinitialized. If the these configuration registers change from the initialized values, these registers must be reconfigured to the required setting for the application.

---



---

#### NOTE

In the DIAGNOSTIC state the following considerations must be taken into account if a manual run of the LBIST is initiated by setting the LBIST\_EN bit to 1. Setting the LBIST\_EN bit to 1 clears the DIAG\_EXIT\_MASK bit to 0. If the DIAG\_EXIT\_MASK bit is being used to hold the device in the DIAGNOSTIC state for software debug, it must be set again to 1 after LBIST completion to stay in the DIAGNOSTIC state. The DIAGNOSTIC state time-out counter stops only during the running of the LBIST. After the LBIST is complete, the time-out counter continues from the last value. For a transition from the DIAGNOSTIC state to the ACTIVE state, the DIAG\_EXIT bit must be set to 1.

---

During the BIST run, the device cannot monitor the state of regulated supplies and cannot respond to any SPI command, and therefore cannot monitor the state of the MCU through the watchdog timer. During the BIST run, the ENDRV pin is pulled low and the watchdog fail counter reinitializes to 5. After the BIST is complete, the following functions and registers reinitialize:

- DEV\_STAT
- SAFETY\_STAT\_2
- SAFETY\_STAT\_4
- SAFETY\_STAT\_5 (but FSM[2:0] will immediately update to reflect the current device state)
- WD\_TOKEN\_VALUE
- WD\_STATUS
- SAFETY\_CHECK\_CTRL
- DIAG\_CFG\_CTRL
- DIAG\_MUX\_SEL

A running LBIST is indicated in the LBIST\_RUN bit (bit D1) in the SAFETY\_STAT\_3 register. This bit is set to 1 while the LBIST is running and is cleared to 0 when the LBIST is complete. After the LBIST run, completion of the whole BIST is confirmed by the MCU by reading 0 for both the LBIST\_RUN and ABIST\_RUN bits.

In case of an LBIST failure in the DIAGNOSTIC state, the device enters the SAFE state. The external MCU can detect the LBIST failure by reading the LBIST\_ERR bit in the SAFETY\_STAT\_3 register. In case of an LBIST failure while in the ACTIVE state, the device sets the LBIST\_ERR status flag, but no state transition occurs. Because the ABIST is run during the LBIST, the ABIST\_ERR bit can also be monitored by the MCU.

#### 5.4.8 Junction Temperature Monitoring and Current Limiting

Each LDO with an internal power FET has junction temperature monitoring with overtemperature protection (thermal shutdown). In case of an overtemperature condition, a regulated supply can re-enable only after the overtemperature condition is removed.

For the VSOUT1 regulator, the overtemperature condition disables the regulator and clears the enable bit (VSOUT1\_EN), while all other regulators remain enabled. When the VSOUT1 overtemperature condition is gone, the external MCU must set the enable control bit again to re-enable the regulator.

The VDD3/5 and VDD6 regulators share an overtemperature protection circuit. A overtemperature event disables the VDD3/5 regulator. If the NMASK\_VDD3/5\_OT is set to 1 (default), the device transitions to the STANDBY state. If the NMASK\_VDD3/5\_OT bit is cleared to 0, the device transitions to the RESET state when the VDD3/5 output reaches the UV level for the VDD3/5 regulator. In both cases the NRES pin goes low and resets the external MCU and the ENDRV pin is low. TI recommends using the device with the NMASK\_VDD3/5\_OT bit set to 1.

For the VDD5 regulator, the overtemperature condition clears the VDD5\_EN enable bit and transitions to the RESET state. NRES pin goes low and resets the MCU and the ENDRV pin is low. All other regulators remain enabled. When the VDD5 overtemperature condition is gone, the MCU must set the enable control bit again to re-enable the regulator.

The VDD6, VDD3/5, VDD5, and VSOUT1 regulators include a current-limit circuit for protection against excessive power consumption and thermal overstress.

Table 5-3 lists an overview of the overtemperature and overcurrent protections for the supply output rails.

**Table 5-3. Overtemperature and Overcurrent Protection Overview**

VOLTAGE RAIL	OVERTEMPERATURE PROTECTION		OVERCURRENT PROTECTION	
	THRESHOLD (°C)	IMPACT ON DEVICE BEHAVIOR	CURRENT-LIMIT	IMPACT ON DEVICE BEHAVIOR
VDD6	175 to 210 (shared with VDD6 and VDD3/5)	Sets VDD3/5_OT (in SAFETY_STAT_1) when NMASK_VDD3/5_OT = 1, STANDBY state when NMASK_VDD3/5_OT = 0, disables VDD3/5, RESET when VDD3/5 reaches UV level	1.5 to 2.5 A	None
VDD3/5			350 to 650 mA	Sets VDD3/5_ILIM (in SAFETY_STAT_1)
VDD5	175 to 210	Sets VDD5_OT (in SAFETY_STAT_1) when NMASK_VDD5_OT = 1, clears VDD5_EN (in SENS_CTRL) and VDD5 switched off, RESET state when NMASK_VDD5_OT = 0, overtemperature indicated in VDD5_OT	350 to 650 mA	Sets VDD5_ILIM (in SAFETY_STAT_1)
VDD1	None	N/A	None	N/A
VSOUT1	175 to 210	Sets VSOUT1_OT (in SAFETY_STAT_1) clears VSOUT1_EN (in SENS_CTRL) and VSOUT1 disabled	100 to 500 mA	DIAG_OUT through digital MUX for VSOUT1_CL

### 5.4.9 Diagnostic MUX and Diagnostic Output Pin (DIAG\_OUT)

Analog and digital critical signals, which are not directly connected to the MCU, are switched by a multiplexer to the external DIAG\_OUT pin. The programming of the multiplexer is done with the DIAG\_MUX\_SEL register. The digital signals are buffered to have sufficient drive capabilities.

This multiplexer facilitates external pin-interconnect tests by feeding back the input pin state or feeding back internal module self-test status or safety comparator outputs.

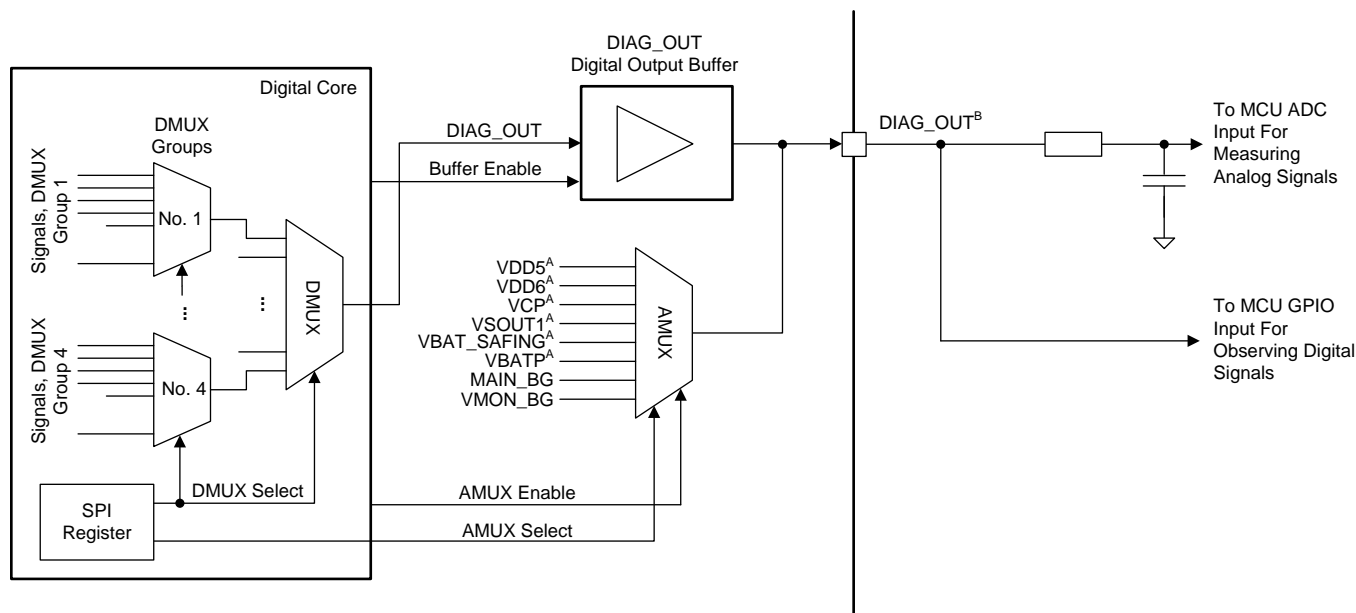

- A. These analog signals are multiplexed out with a divide ratio
- B. If the application must measure analog signals with an MCU ADC and monitor digital signals with an MCU GPIO, the application design must assure the GPIO input stage does not affect the ADC measurements. If isolating the MCU GPIO is not possible within the MCU, the application design must achieve the necessary isolation externally.

**Figure 5-4. Diagnostic Output Pin, DIAG\_OUT**

In case the DIAG\_OUT pin is connected to a mixed analog or digital input pin of the MCU, TI recommends configuring this MCU input pin and the DIAG\_OUT pin simultaneously in accordance with the desired type of signal (analog or digital). The type of signal (analog or digital) on the DIAG\_OUT pin can be configured with the MUX\_CFG[1:0] bits in the DIAG\_CFG\_CTRL register. The DIAG\_OUT multiplexer can be globally enabled and disabled with bit 7 in the DIAG\_CFG\_CTRL register. When disabled, the DIAG\_OUT pin is in the high-ohmic state (tri-state).

#### NOTE

When enabling the DIAG\_OUT MUX while using SPI communication, the SDO pin is not in the high impedance state while the NCS pin is high and the DIAG\_OUT MUX is enabled. Software or hardware modification may be required in the application. For hardware modifications check the SDO threshold level and drive capability if resistors are used to adjust the voltage level of the SDO pin on the SPI bus or use a buffer gate with an enable and tri-state output such as the [SN74AHC1G125](#) to allow the downstream SDO signal to be in the high impedance state if required in the application while the NCS pin is high even if the DIAG\_OUT MUX is enabled.

### 5.4.9.1 Analog MUX (AMUX)

Table 5-4 lists the selectable-analog internal signals on the DIAG\_OUT pin. In the DIAG\_CFG\_CTRL register, the MUX\_CFG[1:0] bits must be set to 10b for the analog MUX mode.

**Table 5-4. Analog MUX Selection Table**

SIGNAL NUMBER	VOLTAGE RAIL or SIGNAL NAME	DESCRIPTION	SUPPLY RANGE <sup>(1)</sup>	DIVIDE RATIO	DIVIDE RATIO ACCURACY <sup>(2)</sup>		OUTPUT RESISTANCE (kΩ)		DIAG_MUX_SEL[7:0]
					MINIMUM	MAXIMUM	MINIMUM	MAXIMUM	
A.1	VDD5	Linear VDD5 regulator output	5.8 to 34 V	2	-2.25 %	0.75 %	20	50	0x01
A.2	VDD6	Switch mode preregulator	5.8 to 34 V	3	-3.75%	0.5 %	30	100	0x02
A.3	VCP	Charge pump	5.8 to 18V	13.5	-6.25 %	2.25 %	90	200	0x04
			5.8 to 34 V		-6.25%	4.75 %			
A.4	VSOUT1	Sensor supply voltage	5.8 to 34 V	4	-0.5 %	1.2 %	40	100	0x08
A.5	VBAT_SAFING	Battery (supply) input for monitoring (VMON) and BG2 functions	5.8 to 18 V	10	-5 %	0 %	125	200	0x10
			5.8 to 34 V		-5 %	5.5 %			
A.6	VBATP	Battery (supply), main power supply	5.8 to 18V	10	-5 %	0 %	125	200	0x20
			5.8 to 34 V		-5 %	5.5 %			
A.7	MAIN_BG	Regulators band-gap reference	5.8 to 34 V	1	NA		3	15	0x40
A.8	VMON_BG	Voltage-monitor band gap	5.8 to 34 V	1	NA		3	15	0x80

(1) The supply range is the input supply range for VBATP and VBAT\_SAFING (VBATP = VBAT\_SAFING).

(2) The given accuracies are without the DC load-current drawn from the DIAG\_OUT pin. For overall accuracy calculation, the divide ratio accuracy and the drop voltage caused by I<sub>DIAG\_OUT</sub> × output resistance must be considered.

In case one of the AMUX signals after the divide ratio is at a voltage above the VDDIO voltage, a clamp becomes active to avoid any voltage level higher than the VDDIO voltage on the DIAG\_OUT pin.

To achieve the fastest stabilization of the signal switched to the DIAG\_OUT pin, following the AMUX switching order from A.1 up to A.8 is not recommended.

The recommendation is to switch the order from high-to-low voltage, starting with A.8. For example: A.8 – A.7 – A.1 – A.2 – A.3 – A.5 – A.6 – A.4.

#### NOTE

The sensor-supply output voltage (VSOUT1) is 0 V in this example. If the VSOUT1 voltage is higher, then the switching order described in the previous example must be changed.

#### NOTE

In the application, a series resistance of at least 100 kΩ is required on the input capacitor filter of the ADC input of the MCU.

### 5.4.9.2 Digital MUX (DMUX)

The following tables list the selectable digital internal signals on the DIAG\_OUT pin. In the DIAG\_CFG\_CTRL register, the MUX\_CFG[1:0] bits must be cleared to 01b for the digital MUX mode.

Most of these signals are internal error signals that influence the device state and behavior of the NRES pin and the ENDRV pin. See Table 5-2 for a more detailed table listing the internal error signals and their impact on the device behavior.

**Table 5-5. Digital MUX Selection Table – Group 1**

SIGNAL NUMBER	SIGNAL NAME	DESCRIPTION	CHANNEL GROUP DIAG_MUX_SEL [6:4]	CHANNEL NUMBER DIAG_MUX_SEL [3:0]
D1.1	RSV	Reserved, logic 0	000b	0000b
D1.2	NAVDD_UV	AVDD undervoltage comparator output (inverted)	000b	0001b
D1.3	BG_ERR1	VMON or main band gap is OFF	000b	0010b
D1.4	BG_ERR2	VMON or main band gap is OFF	000b	0011b
D1.5	NVCP12_UV	VCP12 charge-pump undervoltage comparator (inverted)	000b	0100b
D1.6	VCP12_OV	VCP12 charge-pump overvoltage comparator	000b	0101b
D1.7	VCP17_OV	VCP17 charge-pump overvoltage comparator	000b	0110b
D1.8	NVDD6_UV	VDD6 undervoltage comparator (inverted)	000b	0111b
D1.9	VDD6_OV	VDD6 overvoltage comparator	000b	1000b
D1.10	NVDD5_UV	VDD5 undervoltage comparator (inverted)	000b	1001b
D1.11	VDD5_OV	VDD5 overvoltage comparator	000b	1010b
D1.12	NVDD3/5_UV	VDD3/5 undervoltage comparator (inverted)	000b	1011b
D1.13	VDD3/5_OV	VDD3/5 overvoltage comparator	000b	1100b
D1.14	NVDD1_UV	VDD1 undervoltage comparator (inverted)	000b	1101b
D1.15	VDD1_OV	VDD1 overvoltage comparator	000b	1110b
D1.16	LOCLK	Loss-of-system-clock comparator	000b	1111b

**Table 5-6. Digital MUX Selection Table – Group 2**

SIGNAL NUMBER	SIGNAL NAME	DESCRIPTION	CHANNEL GROUP DIAG_MUX_SEL [6:4]	CHANNEL NUMBER DIAG_MUX_SEL [3:0]
D2.1	RSV	Reserved, logic 0	001b	0000b
D2.2	SYS_CLK	System clock source	001b	0001b
D2.3	DFT	Signal reserved for production test	001b	0010b
D2.4	WD_CLK	Watchdog clock reference (0.55-ms period time)	001b	0011b
D2.5	RST_EXT_CLK	Reset extension oscillator output	001b	0100b
D2.6	T_5US	5- $\mu$ s time reference	001b	0101b
D2.7	T_15US	15- $\mu$ s time reference	001b	0110b
D2.8	T_40US	40- $\mu$ s time reference	001b	0111b
D2.9	T_2MS	2-ms time reference	001b	1000b
D2.10	UC_ERROR/WDI	External MCU ERROR/WDI input pin	001b	1001b
D2.11	SPI_NCS	SPI chip-select input pin	001b	1010b
D2.12	SPI_SDI	SPI slave-data input pin	001b	1011b
D2.13	SPI_CLK	SPI clock input pin	001b	1100b
D2.14	SDO_RDBCK	SPI slave-data output-pin readback	001b	1101b
D2.15	UC_ERROR/WDI	Same signal as D2.10	001b	1110b
D2.16	NRES_EXT_IN	NRES pin readback (reset to external MCU)	001b	1111b

**Table 5-7. Digital MUX Selection Table – Group 3**

SIGNAL NUMBER	SIGNAL NAME	DESCRIPTION	CHANNEL GROUP DIAG_MUX_SEL [6:4]	CHANNEL NUMBER DIAG_MUX_SEL [3:0]
D3.1	RSV	Reserved, logic 0	010b	0000b
D3.2	DFT	Signal reserved for production test	010b	0001b
D3.3	DFT	Signal reserved for production test	010b	0010b
D3.4	CP_OV	Charge-pump overvoltage comparator	010b	0011b
D3.5	NCP_UV	Charge-pump undervoltage comparator (inverted)	010b	0100b
D3.6	CP_PH1	Charge-pump switching phase 1	010b	0101b
D3.7	CP_PH2	Charge-pump switching phase 2	010b	0110b
D3.8	CP_DIFF3V	Indicates VCP-VBATP > 3 V	010b	0111b
D3.9	DFT	Signal reserved for production test	010b	1000b
D3.10	NVBAT_UV	VBAT undervoltage comparator (inverted)	010b	1001b
D3.11	VBATP_OV	VBAT overvoltage comparator	010b	1010b
D3.12	VDD5_OT	VDD5 overtemperature	010b	1011b
D3.13	VDD3/5_OT	VDD3/5 overtemperature	010b	1100b
D3.14	VSOUT1_OT	VSOUT1 overtemperature	010b	1101b
D3.15	VDD5_CL	VDD5 current-limit	010b	1110b
D3.16	VDD3_CL	VDD3 current-limit	010b	1111b

**Table 5-8. Digital MUX Selection Table – Group 4**

SIGNAL NUMBER	SIGNAL NAME	DESCRIPTION	CHANNEL GROUP DIAG_MUX_SEL [6:4]	CHANNEL NUMBER DIAG_MUX_SEL [3:0]
D4.1	RSV	Reserved, logic 0	011b	0000b
D4.2	VSOUT1_CL	VSOUT1 current-limit	011b	0001b
D4.3	NVSOUT1_UV	VSOUT1 undervoltage comparator (inverted)	011b	0010b
D4.4	VSOUT1_OV	VSOUT1 overvoltage comparator	011b	0011b
D4.5	NDVDD_UV	DVDD undervoltage comparator (inverted)	011b	0100b
D4.6	DVDD_OV	DVDD overvoltage comparator	011b	0101b
D4.7	RSV	Reserved	011b	0110b
D4.8	VS_TRK_MODE	VSOUT1 in track-mode indication	011b	0111b
D4.9	VMON_TRIM_ERR	VMON trim error	011b	1000b
D4.10-16	RSV	Reserved	011b	1001b-1111b

**Table 5-9. Digital MUX Selection Table – Group 5**

SIGNAL NUMBER	SIGNAL NAME	DESCRIPTION	CHANNEL GROUP DIAG_MUX_SEL [6:4]	CHANNEL NUMBER DIAG_MUX_SEL [3:0]
D5.1	RSV	Reserved, logic 0	111b	0000b
D5.2	TI_TEST_MODE	TI production test mode indication	111b	0001b
D5.3-16	DFT	Signal reserved for production test	111b	0010b-1111b

A diagnostic check at the SDO digital-output pin is also possible in DMUX mode. For this diagnostic check, the following sequence is required:

1. The MUX\_CFG[1:0] configuration must be set to 01b for DIGITAL MUX mode.
2. The SPI NCS must be kept HIGH.
3. The state of the SDO pin is controlled by the SPI\_SDO bit (bit D6 in the DIAG\_CFG\_CTRL register).

During this SDO check at the SDO pin, the DIAG\_OUT pin is kept low if no signal from the Digital MUX Selection table is selected.

#### 5.4.9.3 Diagnostic MUX Output State (by MUX\_OUT bit)

For a diagnostic interconnect check between the DIAG\_OUT pin and the MCU analog-digital input pin, the state of the DIAG\_OUT pin is controlled with the SPI bit, MUX\_OUT, in the DIAG\_CFG\_CTRL register. To use this mode, the MUX\_CFG[1:0] bits must be set to 00b in the DIAG\_CFG\_CTRL register.

#### 5.4.9.4 MUX Interconnect Check

For performing a diagnostic interconnect check at the digital input pins (ERROR/WDI, NCS, SDI, and SCLK), the MUX\_CFG[1:0] bits in the DIAG\_CFG\_CTRL register must be set to 11b. The INT\_CON[2:0] bits in the DIAG\_CFG\_CTRL register can select which of these digital inputs to be multiplexed to the DIAG\_OUT pin (see the description of DIAG\_CFG\_CTRL register in [Section 5.5.1](#)).

#### 5.4.10 Watchdog Timer (WD)

The watchdog monitors the correct operation of the MCU. This watchdog requires specific triggers, or messages, from the MCU in specific time intervals to detect correct operation of the MCU. The MCU can control the logic level of the ENDRV pin with the ENABLE\_DRV bit when the watchdog detects correct operation of the MCU. When the watchdog detects incorrect operation of the MCU, the device pulls the ENDRV pin low. This ENDRV pin can be used in the application as a control signal to deactivate the power output stages, for example a motor driver, in case of incorrect operation of the MCU. This function is consequently referred to as the watchdog-enabled function.

The watchdog has two different modes, which are defined as follows:

**Trigger mode:** In trigger mode, the MCU applies a trigger (pulse) on the ERROR/WDI pin to send the required watchdog event for trigger mode. The watchdog operates in trigger mode as the default mode when the device goes from the RESET state to the DIAGNOSTIC state. The MCU error signal monitor (ESM) should not be used when the watchdog operates in trigger mode.

**Question-answer mode (Q&A mode):** In Q&A mode, the MCU sends watchdog answers through SPI.

To select the Q&A mode, the MCU must set the WD\_CFG bit (bit 5) in the safety-function configuration register (SAFETY\_FUNC\_CFG) while in the DIAGNOSTIC state. When the watchdog operates in Q&A mode, the MCU error signal monitor (ESM) may be used.

#### 5.4.11 Watchdog Fail Counter, Status, and Fail Event

The watchdog includes a watchdog fail counter (WD\_FAIL\_CNT[2:0]) which increments because of *bad events* or decrements because of *good events*. When the value of the watchdog fail counter is 5 or more, the watchdog status is out-of-range and the ENDRV pin is low (the watchdog-enabled function is disabled).

When the watchdog fail counter is 4 or less, the watchdog status is in-range and the watchdog no longer disables the watchdog-enabled function. In this case, the device pulls up the ENDRV pin when the ENABLE\_DRV control bit (in the SAFETY\_CHECK\_CTRL register) is set and when the device detects no other errors that impact the level of the ENDRV pin.

The watchdog fail counter operates independently of the state of the watchdog reset configuration bit (bit 3), WD\_RST\_EN, in the SAFETY\_FUNC\_CFG register.

The watchdog fail counter responds as follows:

- A *good event* decrements the fail counter by one, down to the minimum of zero.
- A *bad event* increments the fail counter by one, up to the maximum of seven.
- A *time-out event* increases the fail counter by one, up to the maximum of seven, and sets the TIME\_OUT flag (WD\_STATUS register, bit 1).

The definitions of *good event*, *bad event* and *time-out event* are listed [Section 5.4.14](#) and [Section 5.4.15](#).

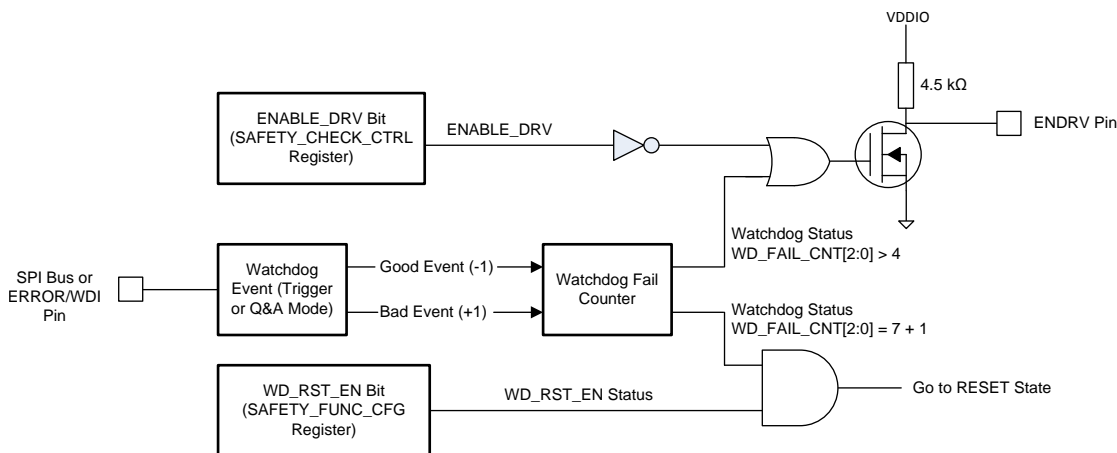

Figure 5-5. Watchdog Impact on ENDRV and RESET

Table 5-10. Watchdog Status for Range of the Watchdog Fail Counter Value

WATCHDOG FAIL COUNTER WD_FAIL_CNT[2:0]	000b THROUGH 100b	101b THROUGH 111b	111b
The watchdog status is based on the WD_FAIL_CNT[2:0] value.	Watchdog in-range	Watchdog is out-of-range	If the WD_RST_EN bit is set to 1, the NRES pin is pulled low, the device is in the RESET state on next "bad" or "time-out" event to the watchdog

The watchdog fail counter is initialized to a count of 5 when the device enters the DIAGNOSTIC state (after going through the RESET state) and when the device transitions from the DIAGNOSTIC state to the ACTIVE state.

When the watchdog fail counter reaches a count of 7, another *bad event* does not change the counter: the counter remains at 7. However, if the watchdog reset is enabled (WD\_RST\_EN bit in the SAFETY\_FUNC\_CFG register is set to 1), on the next *bad event* or *time-out event* (7 + 1) the device enters the RESET state and resets the MCU by pulling the NRES pin low. In the RESET state, the watchdog fail counter reinitializes to 5. If the watchdog fail counter is at seven when the WD\_RST\_EN bit is set to 1, the device immediately enters the RESET state without requiring another *bad event* or *time-out event*.

### 5.4.12 Watchdog Sequence

Each watchdog sequence begins with a Window 1 followed by a Window 2. The MCU can program the time periods of Window 1 ( $t_{WIN1}$ ) and Window 2 ( $t_{WIN2}$ ) with the WD\_WIN1\_CFG and WD\_WIN2\_CFG registers respectively when the device is in the DIAGNOSTIC state. When the device goes from the RESET state to the DIAGNOSTIC state, the watchdog sequence begins with the default  $t_{WIN1}$  and  $t_{WIN2}$  time periods.

Use Equation 1 and Equation 2 to calculate the minimum and maximum values for the  $t_{WIN1}$  time period. Use Equation 3 and Equation 4 to calculate the minimum and maximum values for the  $t_{WIN2}$  time period.

$$t_{WIN1\_MIN} = [(RT[6:0] - 1) \times 0.55 \times 0.95] \text{ ms}$$

where

- The bits RT[6:0] are located in the WD\_WIN1\_CFG SPI register.

(1)

$$t_{WIN1\_MAX} = (RT [6:0] \times 0.55 \times 1.05) \text{ ms}$$

where

- The bits RT[6:0] are located in the WD\_WIN1\_CFG SPI register.

(2)

$$t_{WIN2\_MIN} = [(RW[4:0] + 1) \times 0.55 \times 0.95] \text{ ms}$$

where

- The bits RW[4:0] are located in the WD\_WIN2\_CFG SPI register.

(3)

$$t_{WIN2\_MAX} = [(RW[4:0] + 1) \times 0.55 \times 1.05] \text{ ms}$$

where

- The bits RW[4:0] are located in the WD\_WIN2\_CFG SPI register.

(4)

If the MCU stops sending *events*, or stops *feeding the watchdog* during the watchdog sequence, the watchdog considers this lack of response from the MCU a *time-out event (no response event)*. This sets the TIME\_OUT status bit (bit 1 in the WD\_STATUS register) and increments the watchdog fail counter. Immediately following a *time-out event* the next watchdog sequence is started.

Based on the Window 1 and Window 2 time periods, the watchdog sequence and time-out time periods are calculated as follows:

$$t_{SEQUENCE\_MIN} = t_{TIMEOUT\_MIN} = t_{WIN1\_MIN} + t_{WIN2\_MIN} \quad (5)$$

$$t_{SEQUENCE\_MAX} = t_{TIMEOUT\_MAX} = t_{WIN1\_MAX} + t_{WIN2\_MAX} \quad (6)$$

The watchdog uses the internal system clock of the device ( $\pm 5\%$  accuracy) as a time reference for creating the 0.55-ms watchdog time step. WINDOW 1 may be up to one 0.55-ms watchdog time step shorter than programmed as indicated by Equation 1.

#### NOTE

Because of the uncertainty in the Window 1 and Window 2 time periods, TI recommends using settings for Window 1 and Window 2 of two or higher. Window 2 could be set as low as one, assuming Window 1 is set to six or lower. The response from the MCU should be targeted to the mid point of known timing for Window 2. As Window 1 setting is increased above six, the device system-clock tolerance ( $\pm 5\%$ ) becomes large compared to a setting of one in Window 2 not allowing for a known time range for a response in Window 2, so Window 2 setting must be scaled with Window 1 to allow timing margin.

### 5.4.13 MCU to Watchdog Synchronization

To synchronize the MCU with the watchdog sequence, the MCU can write to either the WIN1\_CFG or WIN2\_CFG registers to start a new watchdog sequence. After a write access to the WIN1\_CFG or WIN2\_CFG register by the MCU (even when these registers are locked or when the device is in the ACTIVE or the SAFE state), the device immediately starts a new watchdog sequence and increments the watchdog fail counter. Therefore a write access to the WD\_WIN1\_CFG or WD\_WIN2\_CFG register only takes effect in this new watchdog sequence.

When the MCU is synchronized with the watchdog sequence, a *good event* from the MCU immediately starts a new watchdog sequence. In this way, the MCU stays synchronized with the watchdog sequence.

See [Figure 6-11](#) for an example software flowchart of how to synchronize the MCU with the TPS65381-Q1 watchdog.

### 5.4.14 Trigger Mode (Default Mode)

When the device goes from the RESET state to the DIAGNOSTIC state, the watchdog operates in trigger mode (default). The first watchdog sequence begins with the default  $t_{WIN1}$  and  $t_{WIN2}$  time periods. The watchdog receives the triggers from the MCU on the ERROR/WDI pin. A rising edge on the ERROR/WDI pin, followed by a falling edge on the ERROR/WDI pin after more than the required pulse time,  $t_{WD\_pulse(max)}$  (32  $\mu$ s), is a trigger. Even a waveform with a longer duration high than low is counted as a trigger if the rising and falling edges meet this requirement.

Window 1, called a CLOSE window, is the first window in the watchdog sequence. A trigger received in Window 1 is a *bad event* and ends Window 1, starts a new watchdog sequence and sets ANSWER\_EARLY flag.

Window 2, called an OPEN window, follows Window 1. At a minimum, Window 2 lasts until a trigger is received. At a maximum, Window 2 lasts until the programmed  $t_{WIN2}$  time. A trigger received in Window 2 (OPEN) is a *good event*. A new watchdog sequence begins immediately after the watchdog receives a trigger in Window 2.

If the MCU stops sending triggers during the watchdog sequence, the watchdog considers this lack of response from the MCU a *time-out event (no response event)*. This sets the TIME\_OUT status bit (bit 1 in the WD\_STATUS register) and increments the watchdog fail counter. Immediately following a *time-out event* a new watchdog sequence is started.

The TIME\_OUT flag can be useful for the MCU software to resynchronize the watchdog trigger pulse events to the required device watchdog timing. When resynchronizing in this way, the MCU detects the TIME\_OUT flag being set. The TIME\_OUT flag being set indicates the *time-out event* and the start of a new watchdog sequence. The MCU should send the trigger with timing so the trigger is in Window 2 (OPEN) of this new watchdog sequence.

---

#### NOTE

If an active SPI frame (nCS is low) is present when the *time-out event* occurs, the TIME\_OUT flag is not latched (set) in the WD\_STATUS register, but the watchdog fail counter still increments. Because the TIME\_OUT flag is not latched, this impacts the resynchronization ability of the MCU and status monitoring. It is recommended to use the synchronization procedure outlined in [Section 5.4.13](#).

---

In trigger mode, the watchdog uses a deglitch filter with the  $t_{WD\_pulse}$  filter time and an internal system clock to create the internally generated watchdog pulse (see [Figure 5-6](#) and [Figure 5-7](#)).

The rising edge of the trigger on the ERROR/WDI pin must occur at least the  $t_{WD\_pulse(max)}$  time before the end of Window 2 (OPEN) to generate a good event.

The window duration times of Window 1 (CLOSE) and Window 2 (OPEN) are programmed through the WD\_WIN1\_CFG and WD\_WIN2\_CFG registers when the device is in the DIAGNOSTIC state. In trigger mode, the window duration time are as follows:

$$t_{WCW\_MIN} (\text{Trigger mode}) = t_{WIN1\_MIN}$$

where

- WCW is a watchdog CLOSE window

(7)

$$t_{WCW\_MAX} (\text{Trigger mode}) = t_{WIN1\_MAX}$$

where

- WCW is a watchdog CLOSE window

(8)

$$t_{WOW\_MIN} (\text{Trigger mode}) = t_{WIN2\_MIN}$$

where

- WOW is a watchdog OPEN window

(9)

$$t_{WOW\_MIN} (\text{Trigger mode}) = t_{WIN2\_MIN}$$

where

- WOW is a watchdog OPEN window

(10)

Use [Equation 1](#) and [Equation 2](#) to calculate the minimum and maximum values for the  $t_{WIN1} = t_{WCW}$  time period. Use [Equation 3](#) and [Equation 4](#) to calculate the minimum and maximum values for the  $t_{WIN2} = t_{WOW}$  time period.

Writing a new Window 1 or Window 2 time to the WD\_WIN1\_CFG or WD\_WIN2\_CFG register immediately begins a new watchdog sequence and increments the watchdog fail counter. A new watchdog sequence is started by a write even when WD\_WIN1\_CFG register and the WD\_WIN2\_CFG SPI register are locked because the device is not in DIAGNOSTIC state or the SPI command SW\_LOCK is blocking a write update to the register values.

The watchdog trigger event is considered a *good-event* if received during a Window 2 (OPEN) window, and is considered a *bad-event* if received during Window 1 (CLOSE) window. A *good-event* ends the current watchdog sequence and starts a new watchdog sequence, therefore the MCU and device watchdog timing stay synchronized.

A *good-event*, *bad-event*, *time-out event*, power-up event, or power-down event ends the current watchdog sequence and starts a new watchdog sequence.

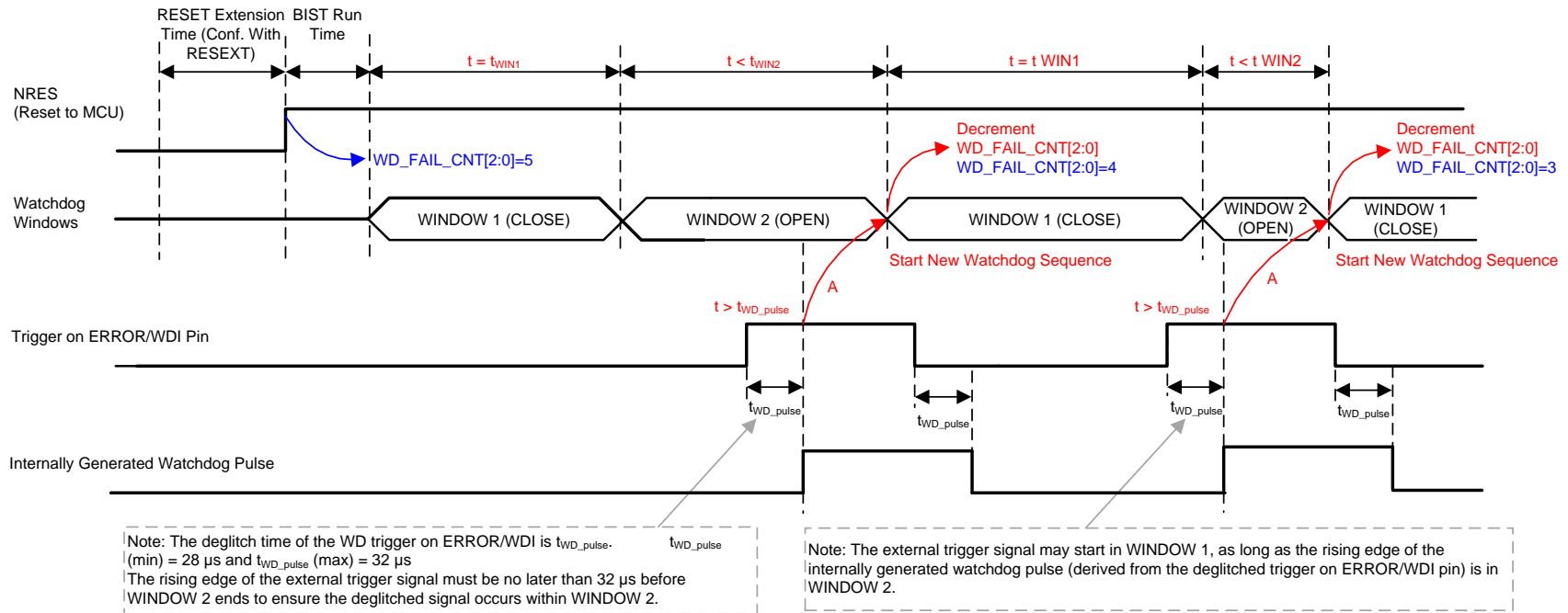

- A. When a *good event* is received in Window 2, 1 system clock-cycle (250 ns, typical) later the next watchdog sequence begins. Therefore the actual length of Window 2 depends on when the MCU sends the *good event*.

Figure 5-6. Example Cases for *Good-Events* in Trigger Mode

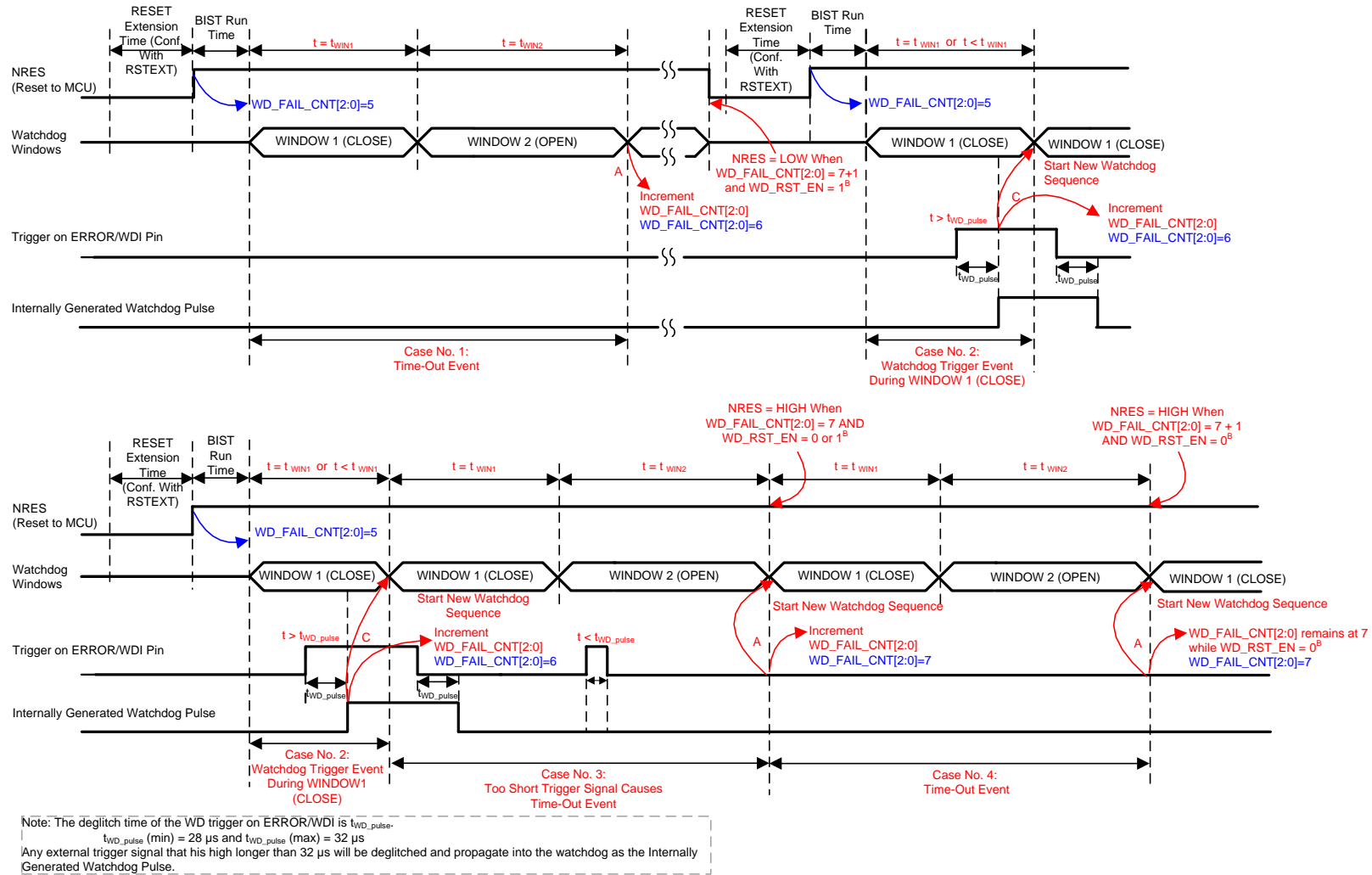

- When a *time-out event* occurs, 1 system clock-cycle (250 ns, typical) later, the next watchdog sequence begins.
- WD\_RST\_EN = 0 per default. To enable a reset from the watchdog once WD\_FAIL\_CNT[2:0] = 7 + 1, WD\_RST\_EN must be set to 1. The notation WD\_FAIL\_CNT[2:0] = 7 + 1 means the next (+ 1) *bad event* or *time-out event* if WD\_FAIL\_CNT[2:0] = 7 while WD\_RST\_EN = 1 will cause a transition to the RESET state. However, when WD\_RST\_EN = 0, the WD\_FAIL\_CNT[2:0] counter does not increment past 7 and the watchdog does not cause a transition to the RESET state.
- When a *bad event* is received in Window 1, 1 system clock-cycle (250 ns, typical) later the next watchdog sequence begins. Therefore the actual length of Window 1 depends on when the MCU sends the *bad event*.

Figure 5-7. Example Cases for *Bad-Event* and *Time-out Events* in Trigger Mode

### 5.4.15 Q&A Mode

Setting the WD\_CFG bit in the SAFETY\_FUNC\_REG register to 1 when the device is in the DIAGNOSTIC state configures the watchdog for Q&A (question and answer) mode. In Q&A mode, the device provides a *question (or TOKEN)* for the MCU in the WD\_TOKEN\_VALUE register. The MCU performs a fixed series of arithmetic operations on the question to calculate the required 32-bit answer. This answer is split into four answer bytes or responses. The MCU writes these answer bytes through SPI one byte at a time into the WD\_ANSWER register. The device verifies that the MCU returned the answer bytes within the specified timing windows, and that the answer bytes are correct.

A *good event* occurs when the MCU sends the correct answer bytes calculated for the current question within the correct watchdog window and in the correct order.

A *bad event* occurs when one of the events that follows occur:

- The MCU sends the correct answer bytes, but not in the correct watchdog window.
- The MCU sends incorrectly calculated answer bytes.
- The MCU returns correct answer bytes in the wrong order (sequence).

If the MCU stops sending answer bytes during the watchdog sequence, the watchdog considers this lack of response from the MCU a *time-out event (no response event)*. This sets the TIME\_OUT status bit (bit 1 in the WD\_STATUS register) and increments the watchdog fail counter. Immediately following a *time-out event* a new watchdog sequence is started.

The TIME\_OUT flag can be useful for the MCU software to resynchronize the watchdog answer timing to the required device watchdog timing. When resynchronizing in this way, the MCU detects the TIME\_OUT flag being set. The TIME\_OUT flag being set indicates the *time-out event* and the start of a new watchdog sequence. The MCU should send the answer bytes with timing so they will be in the correct windows of the new watchdog sequence.

---

#### NOTE

If an active SPI frame (nCS is low) is present when the *time-out event* occurs, the TIME\_OUT flag is not latched (set) in the WD\_STATUS register, but the watchdog fail counter is still incremented. Because the TIME\_OUT flag is not latched this impacts the resynchronization ability of the MCU and status monitoring. It is recommended to use the synchronization procedure outlined in section [Section 5.4.13](#).

---

#### NOTE

In Q&A mode, each watchdog sequence starts with Window 1 (OPEN) followed by Window 2 (CLOSE). The OPEN and CLOSE references for Q&A mode are reversed with respect to those of trigger mode, but the order of the Window 1 and Window 2 is the same as are the registers containing the setting for each window, WD\_WIN1\_CFG and WD\_WIN2\_CFG.

---

#### 5.4.15.1 Watchdog Q&A Related Definitions

The Q&A mode definitions are:

**Question (Token)** The question (token) is a 4-bit word (see [Section 5.4.15.3](#)).

The watchdog provides the question (token) to the MCU when the MCU reads the question (TOKEN[3:0]) from the WD\_TOKEN\_VALUE register.

The MCU can request each new question (token) at the start of the watchdog sequence, but this is not required to calculate the answer. The MCU can also generate the question by implementing the question generation circuit as shown in [Figure 5-9](#). Nevertheless, the answer and, therefore the answer bytes, are always based on the question generated inside the watchdog of the device. So, if the MCU generates a wrong question and gives answer bytes calculated from a wrong question, the watchdog detects a *bad event*.

A new question (token) is generated only when a *good event* occurred in the previous watchdog sequence causing the token counter (internal counter) to increment and generate

a new question (token) as shown in figure [Figure 5-9](#).

**Answer (Response)** The answer (response) is a 32-bit word that is split into four answer bytes or responses: Answer-3 (WD\_TOKEN\_RESP\_3), Answer-2 (WD\_TOKEN\_RESP\_2), Answer-1 (WD\_TOKEN\_RESP\_1), and Answer-0 (WD\_TOKEN\_RESP\_0).

The watchdog receives an answer byte when the MCU writes to the watchdog answer register (the WD\_ANSW[7:0] bits in the WD\_ANSWER register).

For each question, the watchdog requires four correct answer bytes from the MCU in the correct timing and order (sequence). Answer-3, Answer-2, and Answer-1 can be in Window 1 or Window 2 in the correct order, and Answer-0 must be in Window 2 to be detected as a *good event*.

#### 5.4.15.2 Watchdog Sequence in Q&A Mode

The watchdog sequence in Q&A mode ends after the MCU writes the fourth answer byte, Answer-0 (WD\_TOKEN\_RESP\_0), or after a time-out event. A new watchdog sequence starts after the previous watchdog sequence ends.

The window duration times of Window 1 (OPEN) and Window 2 (CLOSE) are programmed through the WD\_WIN1\_CFG and WD\_WIN2\_CFG registers when the device is in the DIAGNOSTIC state. In Q&A mode, the window duration time are as follows:

$$t_{WOW\_MIN} (Q\&A \text{ mode}) = t_{WIN1\_MIN}$$

where

- WOW is a watchdog OPEN window

(11)

$$t_{WOW\_MAX} (Q\&A \text{ mode}) = t_{WIN1\_MAX}$$

where

- WOW is a watchdog OPEN window

(12)

$$t_{WCW\_MIN} (Q\&A \text{ mode}) = t_{WIN2\_MIN}$$

where

- WCW is a watchdog CLOSE window

(13)

$$t_{WCW\_MIN} (Q\&A \text{ mode}) = t_{WIN2\_MIN}$$

where

- WCW is a watchdog CLOSE window

(14)

Use [Equation 1](#) and [Equation 2](#) to calculate the minimum and maximum values for the  $t_{WIN1} = t_{WOW}$  time period. Use [Equation 3](#) and [Equation 4](#) to calculate the minimum and maximum values for the  $t_{WIN2} = t_{WCW}$  time period.

Writing a new Window 1 or Window 2 time to the WD\_WIN1\_CFG or WD\_WIN2\_CFG register immediately begins a new watchdog sequence and increments the watchdog fail counter. A new watchdog sequence is started by a write even when WD\_WIN1\_CFG register and the WD\_WIN2\_CFG SPI register are locked because the device is not in DIAGNOSTIC state or the SPI command SW\_LOCK is blocking a write update to the register values.

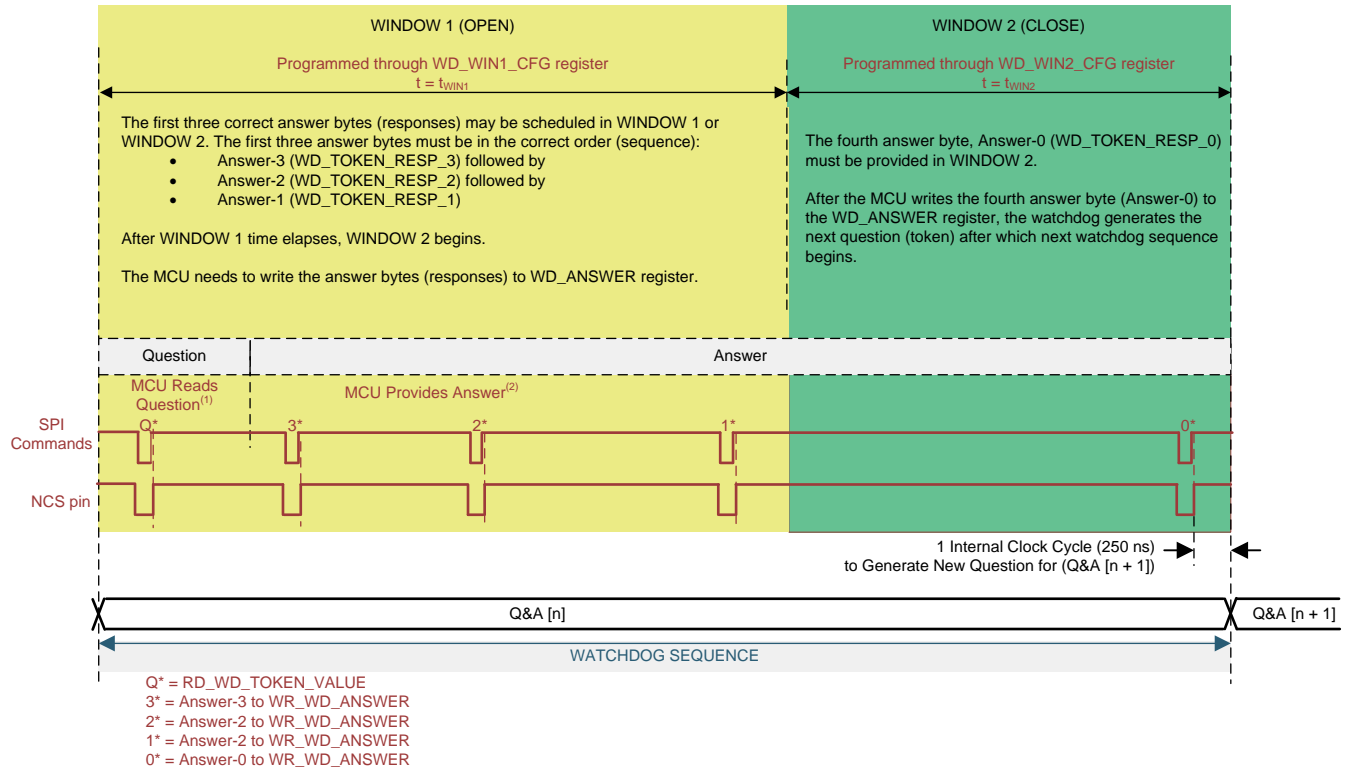

- (1) The MCU is not required to read the question (token). The MCU can begin giving the correct answer bytes Answer-3, Answer-2, Answer-1, anywhere in Window 1 or Window 2. The new question (token) is generated and a new watchdog sequence started within 1 system clock cycle after the final Answer-0 as long as the answer was a *good event*. A *bad event* or *time-out event* causes a new watchdog sequence to start, however a new question (token) is not generated.
- (2) The MCU can put other SPI commands in-between the WR\_WD\_ANSWER commands (even rerequesting the question). These SPI commands have no influence on the detection of a *good event*, as long as the four correct answer bytes are in the correct order, and the fourth correct answer byte is provided in Window 2.

Figure 5-8. Watchdog Sequence in Q&A Mode

### 5.4.15.3 Question (Token) Generation

The watchdog uses a 4-bit token counter (TOKEN\_CNT[3:0] bits in Figure 5-9), and a 4-bit Markov chain to generate a 4-bit question (token). The MCU can read this question in the WD\_TOKEN\_VALUE register, TOKEN[3:0] bits. The watchdog generates a new question when the token counter increments, which only occurs when the watchdog detects a *good event*. The watchdog does not generate a new question when it detects a *bad event* or a *time-out event*. The watchdog does not generate a new question for a watchdog sequence that starts after the MCU writes to the WD\_WIN1\_CFG or WD\_WIN2\_CFG registers.

The token counter provides a clock pulse to the Markov chain when it transitions from 1111b to 0000b. The question counter and the Markov chain are set to the singular default value of 0000b when the device completes the LBIST (either a manual LBIST run or the automotive LBIST run initiated on the transition from the RESET to DIAGNOSTIC state). To leave the singular point, the feedback logic combination is implemented.

Figure 5-9 shows the logic combination for the question (token) generation. The question is in the WD\_TOKEN\_VALUE register, TOKEN[3:0] bits.

The logic combination of the token counter with the WD\_ANSW\_CNT[1:0] status bits (in the WD\_STATUS register) generates the reference answer bytes as shown in Figure 5-9.

4-bit LFSR Polynomial Equation<sup>1</sup>

FDBK[2:1] = 2b'00:  $y = x^4 + x^3 + 1$  (Default Value)

FDBK[2:1] = 2b'01:  $y = x^4 + x^2 + 1$

FDBK[2:1] = 2b'10:  $y = x^3 + x^2 + 1$

FDBK[2:1] = 2b'11:  $y = x^4 + x^3 + x^2 + 1$

Equivalent for Default LFSR Polynomial (Default FDBK value)

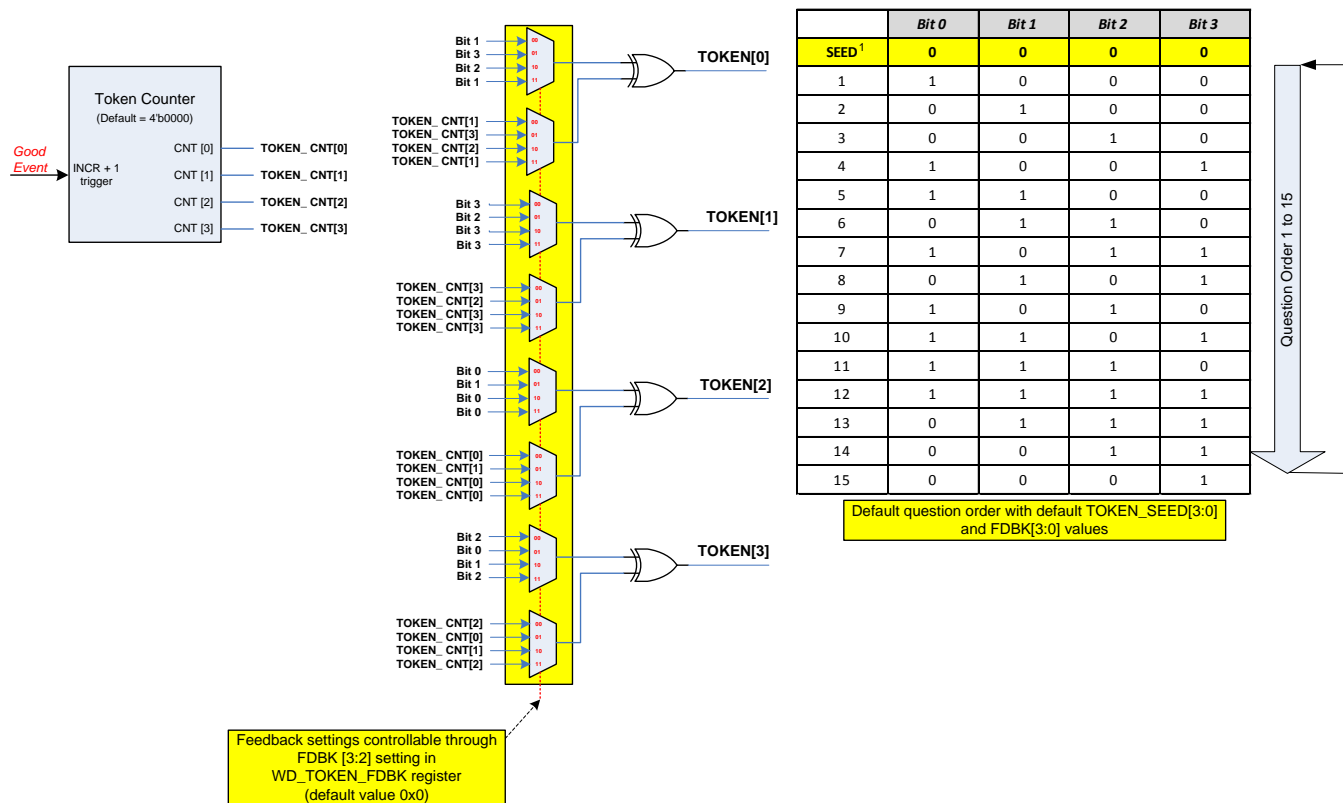
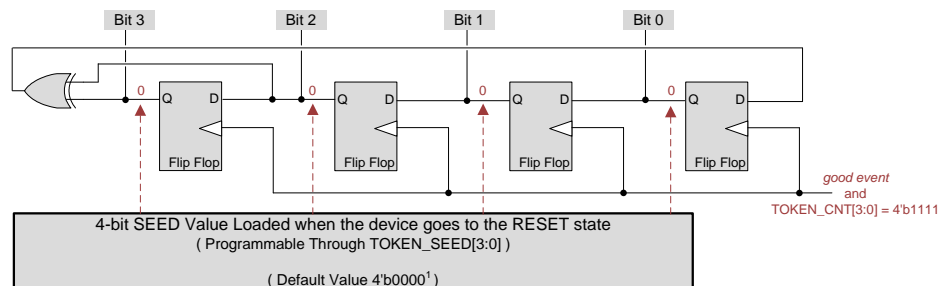

(1) A value of 0000b is a special seed and equates to 0001b, including the default loading of 0000b during power up.

Figure 5-9. Watchdog Question (Token) Generation

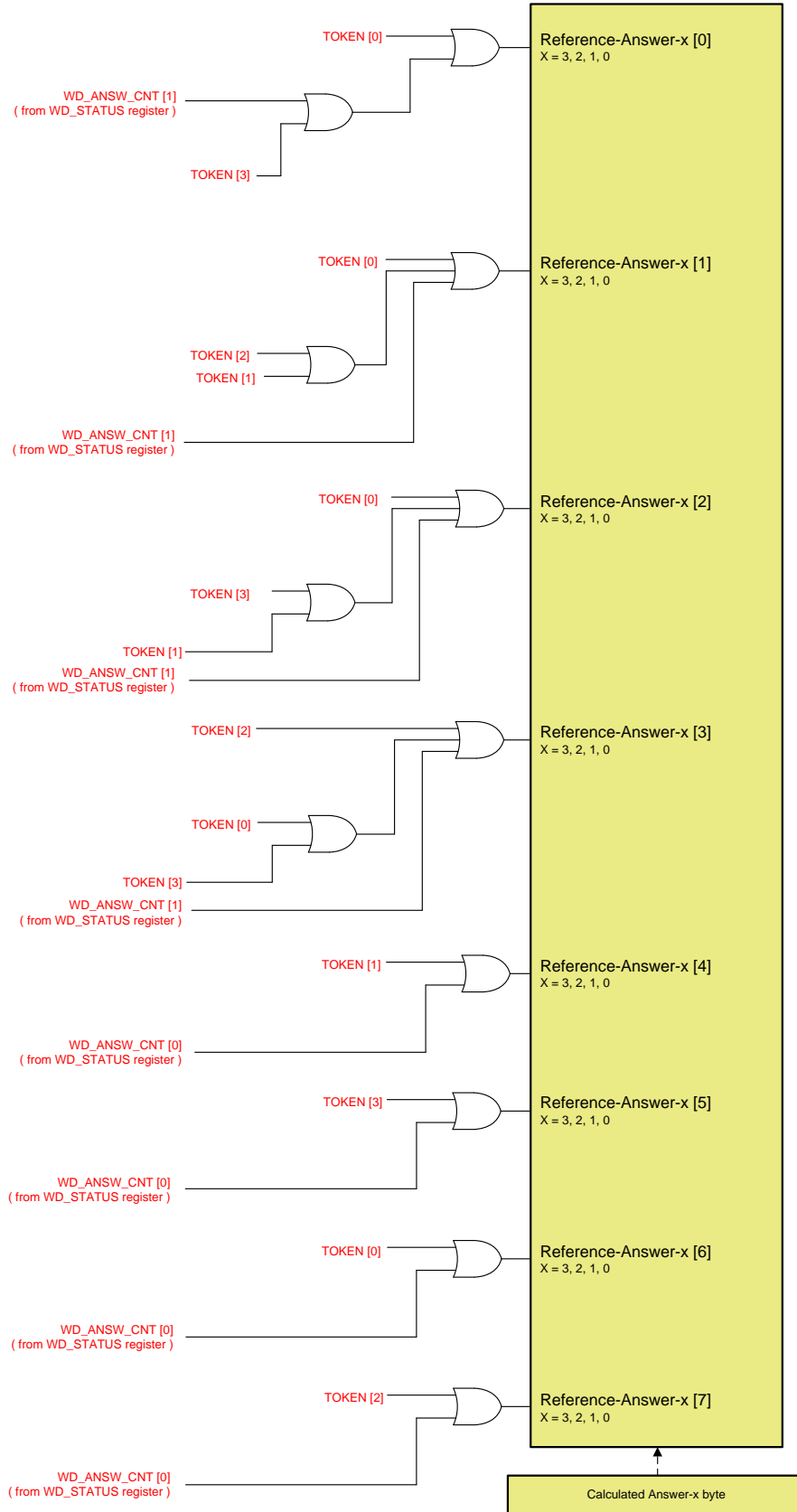

Figure 5-10. Watchdog Answer Calculation

#### 5.4.15.4 Answer Comparison and Reference Answer

The 2-bit, watchdog-answer counter, WD\_ANSW\_CNT[1:0], in the WD\_STATUS register counts the number of received answer bytes and controls the generation of the reference Answer-x byte as shown in [Figure 5-10](#). At the start of each watchdog sequence, the default value of the WD\_ANSW\_CNT[1:0] is 11b to indicate that the watchdog expects the MCU to write Answer-3 (WD\_RESP\_3) in the WD\_ANSWER register.

##### 5.4.15.4.1 Sequence of the 2-bit Watchdog Answer Counter

The sequence of the 2-bit, watchdog answer counter, WD\_ANSW[1:0], is as follows for each counter value:

- WD\_ANSW\_CNT[1:0] = 11b:
  - The watchdog calculates reference Answer-3
  - A write access occurs: the MCU writes Answer-3 (WD\_TOKEN\_RESP\_3) byte in the WD\_ANSWER register.
  - The watchdog compares the reference Answer-3 with the Answer-3 byte in the WD\_ANSWER register.
  - The watchdog decrements the WD\_ANSW\_CNT[1:0] bits to 10b and updates the ANSWER\_ERR flag bit.
- WD\_ANSW\_CNT[1:0] = 10b:
  - The watchdog calculates reference Answer-2
  - A write access occurs: the MCU writes Answer-2 (WD\_TOKEN\_RESP\_2) byte in the WD\_ANSWER register.
  - The watchdog compares the reference Answer-2 with the Answer-2 byte in the WD\_ANSWER register.
  - The watchdog decrements the WD\_ANSW\_CNT[1:0] bits to 01b and updates the ANSWER\_ERR flag bit.
- WD\_ANSW\_CNT[1:0] = 01b:
  - The watchdog calculates reference Answer-1
  - A write access occurs: the MCU writes Answer-1 (WD\_TOKEN\_RESP\_1) byte in the WD\_ANSWER register.
  - The watchdog compares the reference Answer-1 with the Answer-1 byte in the WD\_ANSWER register.
  - The watchdog decrements the WD\_ANSW\_CNT[1:0] bits to 00b and updates the ANSWER\_ERR flag bit.
- WD\_ANSW\_CNT[1:0] = 00b:
  - The watchdog calculates reference Answer-0
  - A write access occurs: the MCU writes Answer-0 (WD\_TOKEN\_RESP\_0) byte in the WD\_ANSWER register.
  - The watchdog compares the reference Answer-0 with the Answer-0 byte in the WD\_ANSWER register.
  - The watchdog updates the ANSWER\_ERR flag bit.
  - The watchdog starts a new watchdog sequence and sets the WD\_ANSW\_CNT[1:0] to 11b.

**Table 5-11. Set of Questions (Tokens) and Corresponding Answer Bytes Using Default Setting of WD\_TOKEN\_FDBK Register**

QUESTION (TOKEN) IN WD_TOKEN_VALUE REGISTER	WD ANSWER (TO BE WRITTEN INTO WD_ANSW REGISTER)			
	Answer-3 (WD_TOKEN_RESP_3)	Answer-2 (WD_TOKEN_RESP_2)	Answer-1 (WD_TOKEN_RESP_1)	Answer-0 (WD_TOKEN_RESP_0)
TOKEN [3:0]	WD_ANSW_CNT [1:0] = 11b	WD_ANSW_CNT [1:0] = 10b	WD_ANSW_CNT [1:0] = 01b	WD_ANSW_CNT [1:0] = 00b
0h	FFh	0Fh	F0h	00h
1h	B0h	40h	BFh	4Fh
2h	E9h	19h	E6h	16h
3h	A6h	56h	A9h	59h
4h	75h	85h	7Ah	8Ah
5h	3Ah	CAh	35h	C5h
6h	63h	93h	6Ch	9Ch
7h	2Ch	DCh	23h	D3h
8h	D2h	22h	DDh	2Dh
9h	9Dh	6Dh	92h	62h
Ah	C4h	34h	CBh	3Bh
Bh	8Bh	7Bh	84h	74h
Ch	58h	A8h	57h	A7h
Dh	17h	E7h	18h	E8h
Eh	4Eh	BEh	41h	B1h
Fh	01h	F1h	0Eh	FEh

#### 5.4.15.5 Watchdog Q&A Mode Sequence Events and WD\_STATUS Register Updates

The watchdog sequence events are as follows for the different scenarios listed:

- A *good event* occurs when all answer bytes are correct in value (the ANSWER\_ERR bit is cleared to 0) and timing. For such a good event, then the events that follow occur:
  - The watchdog fail counter, WD\_FAIL\_CNT[2:0], decrements by one.
  - The token counter increments by one, causing a new question (token) to be generated.
  - The SEQ\_ERR bit resets.
  - The ANSWER\_EARLY bit resets.
- A *bad event* occurs when all answer bytes are correct in value (the ANSWER\_ERR bit is cleared to 0) but not in correct timing. For such a bad event, then the events that follow occur:
  - The watchdog fail counter, WD\_FAIL\_CNT[2:0], increments by one.
  - The token counter does not change, thus the question (token) does not change.
  - The SEQ\_ERR bit is set.
  - The ANSWER\_EARLY bit is set.
- A *bad event* occurs when one or more of the answer bytes are not correct in value (the ANSWER\_ERR bit is set to 1) but in correct timing. For such a bad event, then the events that follow occur:
  - The watchdog fail counter, WD\_FAIL\_CNT[2:0], increments by one.
  - The token counter does not change, thus the question (token) does not change.
  - The SEQ\_ERR bit is set
  - The ANSWER\_EARLY bit is reset

- A *bad event* occurs when one or more of the answer bytes are not correct in value (the ANSWER\_ERR status bit is set to 1) and not in correct timing. For such a bad event, then the events that follow occur:
  - The watchdog fail counter, WD\_FAIL\_CNT[2:0], increments by one
  - The token counter does not change, thus the question (token) does not change.
  - The SEQ\_ERR bit is set.
  - The ANSWER\_EARLY bit is set.
- In case a *time-out event* occurs, then the events that follow occur:
  - The watchdog fail counter, WD\_FAIL\_CNT[2:0], increments by one.
  - The token counter does not change, thus the question (token) does not change.
  - The TIME\_OUT bit is set.
- In case the MCU writes to registers WD\_WIN1\_CFG or WD\_WIN2\_CFG, the events that follow occur:
  - The watchdog fail counter, WD\_FAIL\_CNT[2:0], increments by one.
  - The WD\_CFG\_CHG bit is set.

**Table 5-12. WD\_STATUS Bits Versus Possible Watchdog Sequence Events**

All MCU Answer Bytes Correct?	WATCHDOG SEQUENCE EVENTS				WD_STATUS REGISTER BITS			
	Answer-0 Arrived During WINDOW 2 (CLOSE)	Answer-0 Arrived During WINDOW 1 (OPEN)	Time-out Occurred While Waiting for Answer?	WINDOW 1 or WINDOW 2 Duration Changed?	WD_CFG_CHG	SEQ_ERR	TIME_OUT	ANSWER_EARLY
Yes	Yes	No	No	No	0	0	0	0
Yes	No	Yes	No	No	0	0	0	1
No	Yes	No	No	No	0	1	0	0
No	No	Yes	No	No	0	1	0	1
Yes (first 3 Answer-x)	No	No	Yes	No	0	0	1	0
No	No	No	Yes	No	0	1	1	0
—	—	—	—	Yes	1	0	0	0

#### 5.4.16 MCU Error Signal Monitor (MCU ESM)

This block monitors the external MCU error conditions signaled from the MCU to the device through the ERROR/WDI input pin. The MCU ESM is configurable to monitor two different signaling options depending which functional safety architecture MCU family is being monitored and how the specific MCU family indicates on the error or fault output pin improper operation. The MCU ESM mode is selected through the ERROR\_CFG bit in the SAFETY\_FUNC\_CFG register.

In TMS570 mode the ESM detects a low-pulse signal with a programmable low-pulse duration threshold (see [Section 5.4.16.1](#)). This mode is selected when the ERROR\_CFG bit is set to 1. In PWM mode the ESM detecting a PWM signal with a programmable frequency and duty cycle (see [Section 5.4.16.2](#)). This mode is selected when the ERROR\_CFG bit is cleared to 0 (default). PWM mode can be used as an external clock-monitor function.

The MCU ESM is deactivated by default. To activate it, clear the NO\_ERROR bit to 0 in the SAFETY\_CHECK\_CTRL register.

---

#### NOTE

Activating the MCU ESM is only recommended when the watchdog is configured in Q&A mode, otherwise the ERROR/WDI pin is used both for watchdog trigger input and MCU error signaling.

---

The low-signaling duration threshold (for TMS570 mode) or the expected PWM low-pulse duration (for PWM mode) is set through the SAFETY\_ERR\_PWM\_L register. The expected PWM high-pulse duration (for PWM mode) is set through the SAFETY\_ERR\_PWM\_H register. A detected MCU signaling error is indicated when the ERROR\_PIN\_FAIL bit in the SAFETY\_ERR\_STAT register is set to 1.

---

#### NOTE

An update to a SAFETY\_ERR\_PWM\_x register (only possible in the DIAGNOSTIC state) has an immediate effect. Therefore, if the MCU writes a new value to the SAFETY\_ERR\_PWM\_x register which is less than the value of the current pulse-duration counter value, the MCU ESM immediately detects an error condition on the ERROR/WDI pin. The pulse duration counter then reinitializes to 0 and sets the ERROR\_PIN\_FAIL bit to 1.

---

When the TPS65381-Q1 device is in the DIAGNOSTIC state, the MCU can emulate a signaling error (emulated fault-injection) for a diagnostic check of the error-signal monitor by checking the status of the ERROR\_PIN\_FAIL bit while the NO\_ERROR bit is cleared to 0 (MCU ESM enabled) without a transition to the SAFE state.

**NOTE**

To perform an MCU ESM diagnostic check of the pin while in the DIAGNOSTIC state the following procedure can be used. The ERROR/WDI pin is edge triggered.

1. Clear the ERROR\_PIN\_FAIL bit by clearing it to 0 in the SAFETY\_ERR\_STAT register.
2. Verify the ERROR\_PIN\_FAIL bit is not reset to 1 when the MCU ESM is enabled.
3. Inject a failure on the ERROR/WDI pin specific to the MCU ESM mode of operation.
4. Verify the ERROR\_PIN\_FAIL bit is set to 1 and the ENDRV pin is low even if the ENABLE\_DRV bit is set to 1.
5. Remove the injected failure.
6. Write 0 to clear the ERROR\_PIN\_FAIL bit.
7. Confirm the ERROR\_PIN\_FAIL bit was cleared by reading back the SAFETY\_ERR\_STAT register.
8. Confirm the ENDRV pin returned HIGH when the ENABLE\_DRV bit is set to 1, assuming no other conditions exist that block ENDRV from being HIGH (see [Figure 5-14](#)).

When the TPS65381-Q1 device is in the ACTIVE state, a detected MCU signaling error causes a transition to the SAFE state. A dedicated 4-bit error counter, the DEV\_ERR\_CNT[3:0] bits in the SAFETY\_ERR\_STAT register, counts the transitions from the ACTIVE state to the SAFE state.

The module is covered by the logic BIST (LBIST).

**5.4.16.1 TMS570 Mode**

An error condition is detected when the ERROR/WDI pin remains low longer than the programmed amount of time set by the SAFETY\_ERR\_PWM\_L register. The programmable time range is 5  $\mu$ s to 1.28 ms (typical), with 5- $\mu$ s steps ( $\pm 5\%$ ).

The SAFETY\_ERR\_PWM\_L register must be set to the desired value based on the maximum required time for the TMS570 MCU to detect an error or fault and to potentially recover from or correct the error or fault.

The LOW duration time is as follows:

$$t_{\text{TMS570\_LOW\_MIN}} = (\text{PWML}[7:0]) \times 5 \mu\text{s} \times 0.95 \quad (15)$$

$$t_{\text{TMS570\_LOW\_MAX}} = (\text{PWML}[7:0] + 1) \times 5 \mu\text{s} \times 1.05 \quad (16)$$

Use [Equation 15](#) and [Equation 16](#) to calculate the minimum and maximum values for the LOW duration,  $t_{\text{TMS570\_LOW}}$ . [Figure 5-11](#) shows the error-detection case scenarios.

**NOTE**

The SAFETY\_ERR\_PWM\_L register (PWML[7:0]) should be configured with a minimum of 1 (01h) in the register.

The low-pulse monitoring on the ERROR/WDI pin is implemented as follows:

- When the NO\_ERROR bit is cleared to 0, every falling edge on the ERROR/WDI pin reinitializes the low-pulse duration counter to 0 within one system clock-cycle (250 ns  $\pm 5\%$ ).
- After reinitialization, the low-pulse counter restarts one system clock-cycle (250 ns  $\pm 5\%$ ).
- The low-pulse duration counter increases every 5  $\mu$ s (with  $\pm 5\%$  accuracy) as long as the ERROR/WDI pin is low. A rising edge on the ERROR/WDI pin stops the low-pulse duration counter.
- When low-pulse duration counter is equal to the SAFETY\_ERR\_PWM\_L register setting, an error is detected.

The ERROR\_PIN\_FAIL bit in the SAFETY\_ERR\_STAT register is set within one system clock cycle (250 ns  $\pm 5\%$ ) after detecting an MCU signaling error. When the device is in the ACTIVE state, a transition to the SAFE state occurs after one more system clock-cycle.

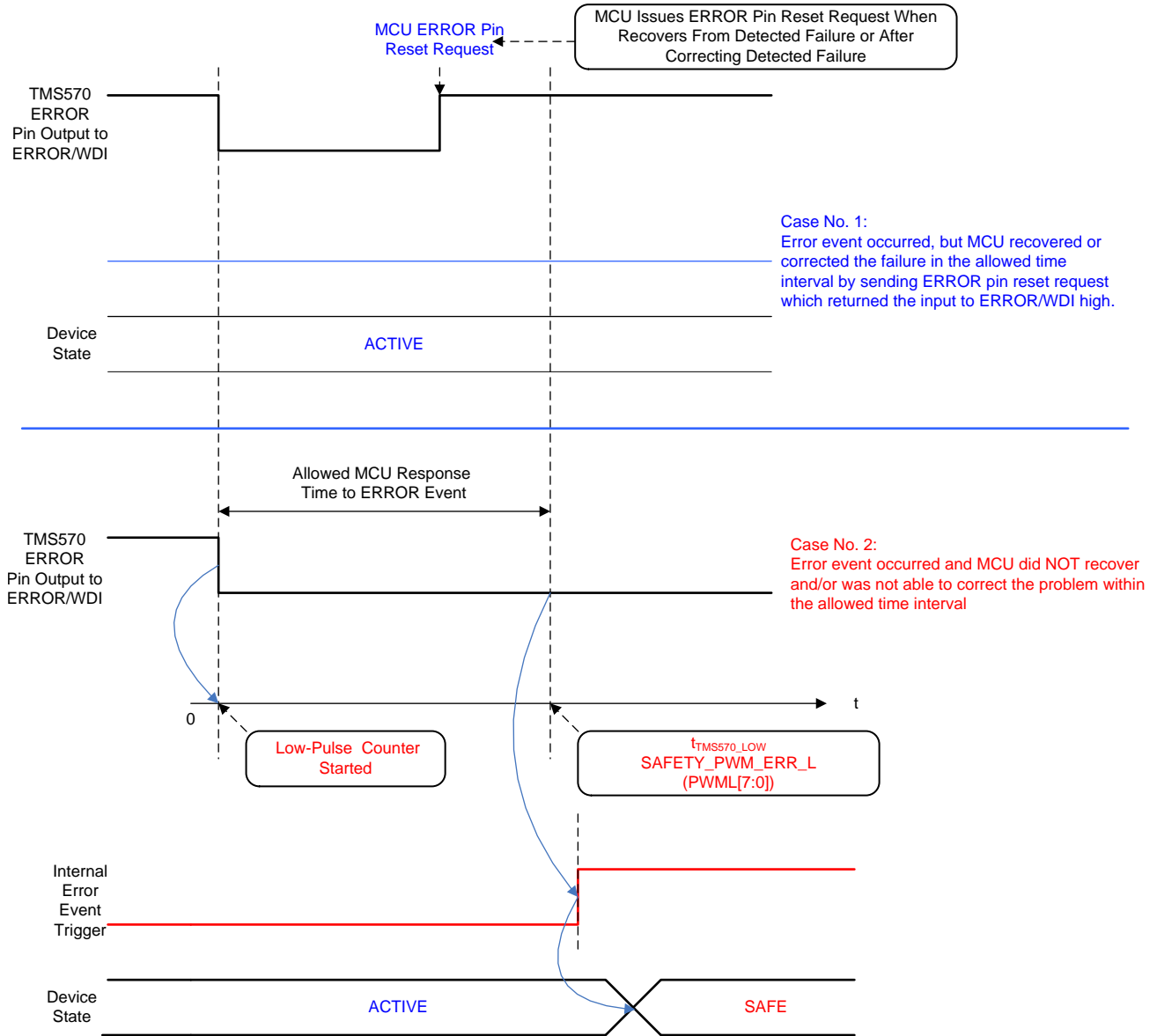

Figure 5-11. Error Detection Case Scenarios in TMS570 Mode

### 5.4.16.2 PWM Mode

An error condition is detected when one of the following occurs on the ERROR/WDI pin:

- The ERROR/WDI pin high-pulse duration exceeds the threshold value programmed by the PWM\_H register.
- The ERROR/WDI pin low-pulse duration exceeds the threshold value programmed by the PWM\_L register.

The MCU ESM does NOT detect an MCU signaling error on the ERROR/WDI pin if both of the following occurs:

- The ERROR pin high-pulse duration is less than the threshold value programmed by the PWM\_H register.
- The ERROR pin low-pulse duration is less than the threshold value programmed by the PWM\_L register.

The programmable time range for the expected HIGH and LOW pulse duration is 15  $\mu$ s to 3.8 ms (typical), with 15- $\mu$ s resolution steps ( $\pm$ 5%).

The HIGH and LOW pulse duration times are programmed through the SAFETY\_ERR\_PWM\_H and SAFETY\_ERR\_PWM\_L registers when the device is in the DIAGNOSTIC state. The pulse duration time are as follows:

$$t_{\text{PWM\_HIGH\_MIN}} = (\text{PWMH}[7:0]) \times 15 \mu\text{s} \times 0.95 \quad (17)$$

$$t_{\text{PWM\_HIGH\_MAX}} = (\text{PWMH}[7:0] + 1) \times 15 \mu\text{s} \times 1.05 \quad (18)$$

$$t_{\text{PWM\_LOW\_MIN}} = (\text{PWML}[7:0]) \times 15 \mu\text{s} \times 0.95 \quad (19)$$

$$t_{\text{PWM\_LOW\_MAX}} = (\text{PWML}[7:0] + 1) \times 15 \mu\text{s} \times 1.05 \quad (20)$$

Use [Equation 17](#) and [Equation 18](#) to calculate the minimum and maximum values for the HIGH pulse duration,  $t_{\text{PWM\_HIGH}}$ . Use [Equation 19](#) and [Equation 20](#) to calculate the minimum and maximum values for the LOW pulse duration,  $t_{\text{PWM\_LOW}}$ .

#### NOTE

The SAFETY\_ERR\_PWM\_H (PWMH[7:0]) and SAFETY\_ERR\_PWM\_L (PWML[7:0]) register should be configured with a minimum of 1 (01h) in the registers.

The monitoring of the high-pulse duration and low-pulse duration is implemented as follows:

LOW pulse monitoring:

- Every falling edge on the ERROR/WDI pin, or setting the NO\_ERROR bit from 1 to 0 when the ERROR/WDI pin is low, reinitializes the low-pulse duration counter to 0 within one system clock-cycle (250 ns  $\pm$ 5%).
- After reinitialization, the low-pulse counter restarts after one system clock-cycle (250 ns  $\pm$ 5%).
- The low-pulse duration counter increases every 15  $\mu$ s ( $\pm$ 5%) while the ERROR/WDI pin remains low.
- When the low-pulse duration counter is equal to the SAFETY\_ERR\_PWM\_L register setting, an error is detected.

HIGH pulse monitoring:

- Every rising edge on the ERROR/WDI pin, or setting the NO\_ERROR bit from 1 to 0 when the ERROR/WDI pin is high, reinitializes the high-pulse duration counter to 0 within one system clock-cycle (250 ns  $\pm$ 5%).
- After reinitialization, the high-pulse counter restarts after one system clock-cycle (250 ns  $\pm$ 5%).
- The high-pulse duration counter increases every 15  $\mu$ s (with  $\pm$  5% accuracy) while the ERROR/WDI pin remains high.
- When the high-pulse duration counter is equal to the SAFETY\_ERR\_PWM\_H register setting, an error is detected.

**NOTE**

The ERROR/WDI pin is edge triggered, to synchronize the MCU to the MCU ESM module, while in the DIAGNOSTIC state the MCU should start sending the desired PWM signal. On the first falling or rising edge the MCU ESM detects the edge and starts the internal timers in sync with the edge so the MCU and MCU ESM are synchronized. The MCU ESM resynchronizes to the MCU on every rising and falling edge. While in the DIAGNOSTIC state, when synchronization has occurred the ERROR\_PIN\_FAIL flag should be cleared.

---

The ERROR\_PIN\_FAIL bit in the SAFETY\_ERR\_STAT register is set within one system clock cycle (250 ns  $\pm$ 5%) after detecting an MCU signaling error. When the device is in the ACTIVE state, a transition to the SAFE state occurs after one more system clock-cycle.

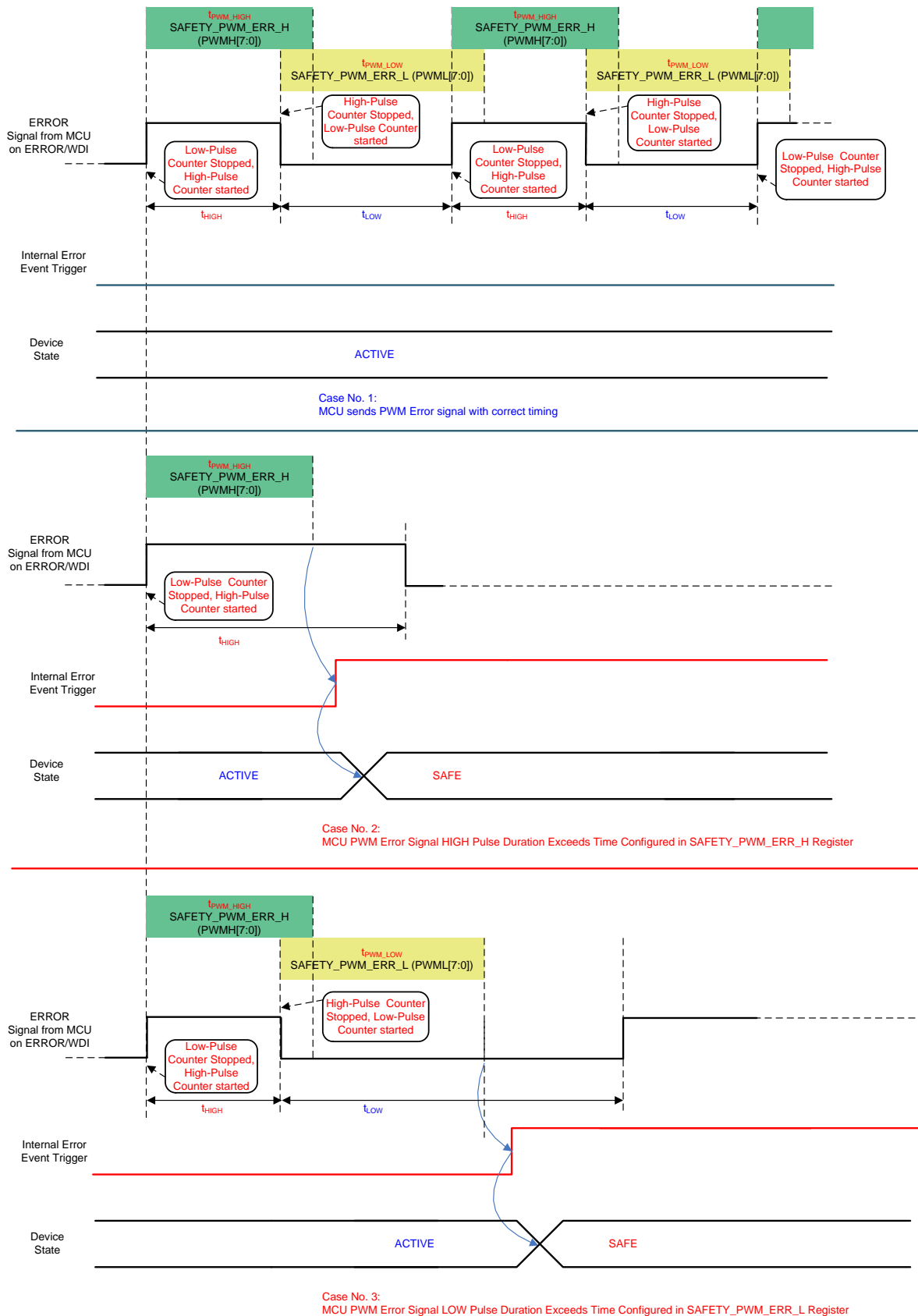

Figure 5-12. Error Detection Case Scenarios in PWM Mode

### 5.4.17 Device Configuration Register Protection

This function offers a mechanism to help protect safety SPI-mapped registers by means of SPI write-access protection and CRC check.

The register access protection includes two distinctive features:

- A register cannot be written after write-access lock protection is set. The lock is cleared by software or by a power-on reset.
- CRC protection for configuration registers.

A CRC occurs on safety data after a SPI write updates to verify the SPI register contents are correctly programmed. The CRC controller is a diagnostic module, which performs the CRC to verify the integrity of the SPI-mapped register space. A signature representing the content of the safety registers is obtained when the content is read into the CRC controller. The responsibility of the CRC controller is to calculate the signature for a set of data and then compare the calculated signature value against a predetermined good-signature value. The predetermined CRC signature value is stored in the SAFETY\_CFG\_CRC register. The external MCU uses the SAFETY\_CHECK\_CTRL register to enable a CRC check and the SAFETY\_STAT\_2 register to monitor the status. When enabled, a CRC check on the configuration registers is performed. In case of a detected signature error, the CFG\_CRC\_ERR flag is set in the SAFETY\_STAT\_2 SPI register. The device state and the ENDRV pin state remain unchanged. In case of a detected checksum error with the TPS65381-Q1 device in the DIAGNOSTIC state, clearing the CFG\_CRC\_EN bit to 0 brings the TPS65381-Q1 device into the SAFE state (the ENDRV pin is pulled low).

A standard CRC-8 polynomial is used:  $X^8 + X^2 + X^1 + 1$

The CRC monitor test is covered by a logic BIST.

A 64-bit string is protected by CRC. The following registers are protected:

- SAFETY\_FUNC\_CFG
- DEV\_REV
- SAFETY\_PWD\_THR\_CFG
- SAFETY\_ERR\_CFG
- WD\_TOKEN\_FDBK
- WD\_WIN2\_CFG
- WD\_WIN1\_CFG
- SAFETY\_ERR\_PWM\_L
- DEV\_CFG2
- DEV\_CFG1 (only bit number 6)

Table 5-13 lists the CRC bus structure.

Table 5-13. CRC Bus Structure

REGISTER NAME	64-BIT BUS ORDERING
SAFETY_FUNC_CFG [6:0]	[63:57]
DEV_REV [7:0]	[56:49]
SAFETY_PWD_THR_CFG [3:0]	[48:45]
SAFETY_ERR_CFG [7:0]	[44:37]
WD_TOKEN_FDBK [7:0]	[36:29]
WD_WIN2_CFG [4:0]	[28:24]
WD_WIN1_CFG [6:0]	[23:17]
SAFETY_ERR_PWM_L [7:0]	[16:9]
DEV_CFG2 [7:0]	[8:1]
DEV_CFG1 [6]	0

In the external MCU, the CRC calculation must be performed byte-wise, starting with the lowest byte of the 64-bit bus ordering value. The most significant bit is first in the bit order. The resulting CRC of one calculation is the seed value for the next calculation. The initial seed value is FFh. The CRC result of the eighth byte-wise calculation is the CRC signature value, which must be stored in the SAFETY\_CFG\_CRC register (see Figure 5-13).

64-Bit Bus Ordering Value:

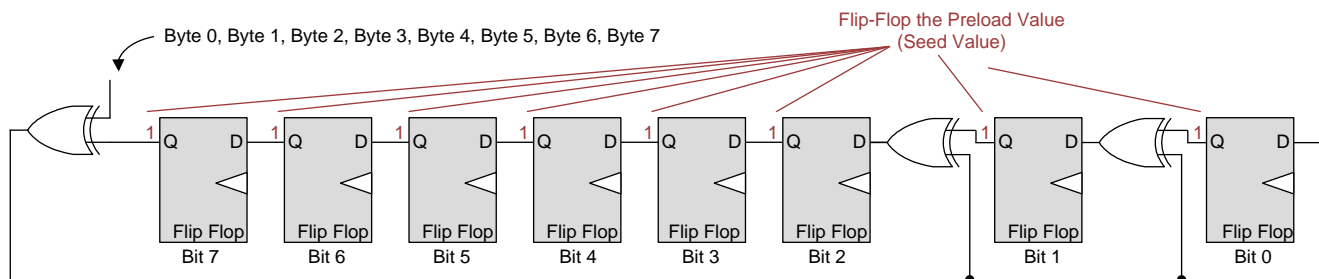
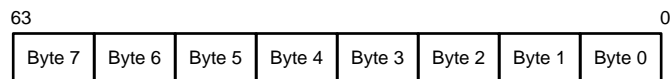

Figure 5-13. CRC Calculation Logic

Table 5-14 lists some CRC calculation examples.

Table 5-14. CRC Calculation Examples

64-BIT BUS ORDERING VALUE	CRC-8 RESULT
0000 0000 0000 0000h	DBh
FFFF FFFF FFFF FFFFh	0Ch
0A0A 0505 0A0A 0505h	D4h
0505 0A0A 0505 0A0Ah	17h
A0A0 5050 A0A0 5050h	2Bh
0A23 E000 18FE 7B80h	1Bh

In case the CRC controller detects a signature error on the configuration registers, care must be used when performing an EEPROM CRC afterwards. In case of a detected signature error in the configuration registers, the device reports an EEPROM signature error when the CFG\_CRC\_EN bit in the SAFETY\_CHECK\_CTRL register is cleared to 0 first before performing the EEPROM CRC by setting the EE\_CRC\_CHK bit in the SAFETY\_BIST\_CTRL register to 1, even when the EEPROM bits do not have an error. Therefore, when performing an EEPROM CRC after a CRC on the configuration registers, the steps must always occur in the following order:

1. Calculate CRC8 in the MCU and store it in the SAFETY\_CFG\_CRC register.
2. Set the CFG\_CRC\_EN bit in the SAFETY\_CHECK\_CTRL register to 1 to perform a CRC on the configuration registers.
3. After the SPI command sets the CFG\_CRC\_EN bit to 1 (for example, after rising edge on NCS), wait at least 2.1  $\mu$ s for the configuration register to complete the CRC.
4. Read the results of the configuration register CRC in the SAFETY\_STAT\_2 register, bit CFG\_CRC\_ERR. If continuous CRC on the configuration register must be performed, clear the CFG\_CRC\_EN bit in the SAFETY\_CHECK\_CTRL register to 0 and repeat beginning with [Step 1](#). If the CRC on the EEPROM registers must be performed, proceed to [Step 5](#).

---

**NOTE**

A correct EEPROM CRC afterwards (as described in [Step 5](#)) clears this CFG\_CRC\_ERR bit. Therefore, TI recommends reading out this CFG\_CRC\_ERR bit before performing the EEPROM CRC.

---

5. Set the EE\_CRC\_CHK bit in the SAFETY\_BIST\_CTRL register to 1 to perform the CRC on the EEPROM registers.
6. After the SPI command sets the EE\_CRC\_CHK bit to 1 (for example, after rising edge on NCS), wait at least 811  $\mu$ s for the EEPROM CRC to finish.
7. Completion of the EEPROM CRC is observed by reading the EE\_CRC\_CHK bit. When the EEPROM CRC is complete, this EE\_CRC\_CHK bit is cleared to 0.
8. Clear the CFG\_CRC\_EN bit in the SAFETY\_CHECK\_CTRL register to 0
9. Read the results of the EEPROM CRC in the SAFETY\_STAT\_2 register, bit EE\_CRC\_ERR.
10. Go back to [Step 1](#).

---

**NOTE**

Returning to [Step 1](#) is not required; returning to [Step 2](#) is also an option.

---



---

**NOTE**

While in the DIAGNOSTIC state, a check can be performed to confirm the CFG\_CRC\_ERR bit is set to 1 on a mismatch between the value stored in the SAFETY\_CFG\_CRC register and the value that is calculated from the configuration registers covered by the CRC8. If the CFG\_CRC\_EN is cleared while the CFG\_CRC\_ERR bit is set to 1, then the device transitions to the SAFE state, set the EE\_CRC\_ERR bit and clear the CFG\_CRC\_EN bit. To avoid this transition to the SAFE state, the CFG\_CRC\_ERR bit must be cleared by running the EEPROM CRC by setting the EE\_CRC\_CHK bit. While the EEPROM CRC is running, the EE\_CRC\_ERR bit is set. Assuming the EEPROM CRC was good, both the EE\_CRC\_ERR and CFG\_CRC\_ERR bits are cleared. To check if the CFG\_CRC\_ERR bit is 0 for a matching CRC, the matching CRC value should be stored in the SAFETY\_CFG\_CRC register. Then the CFG\_CRC\_EN bit must be cleared to 0 and set again to 1 which reruns the CRC on the configuration registers, resulting in the CFG\_CRC\_ERR bit being 0.

---

### 5.4.18 Enable and Reset Driver Circuit

Figure 5-14 shows the reset and enable circuit.

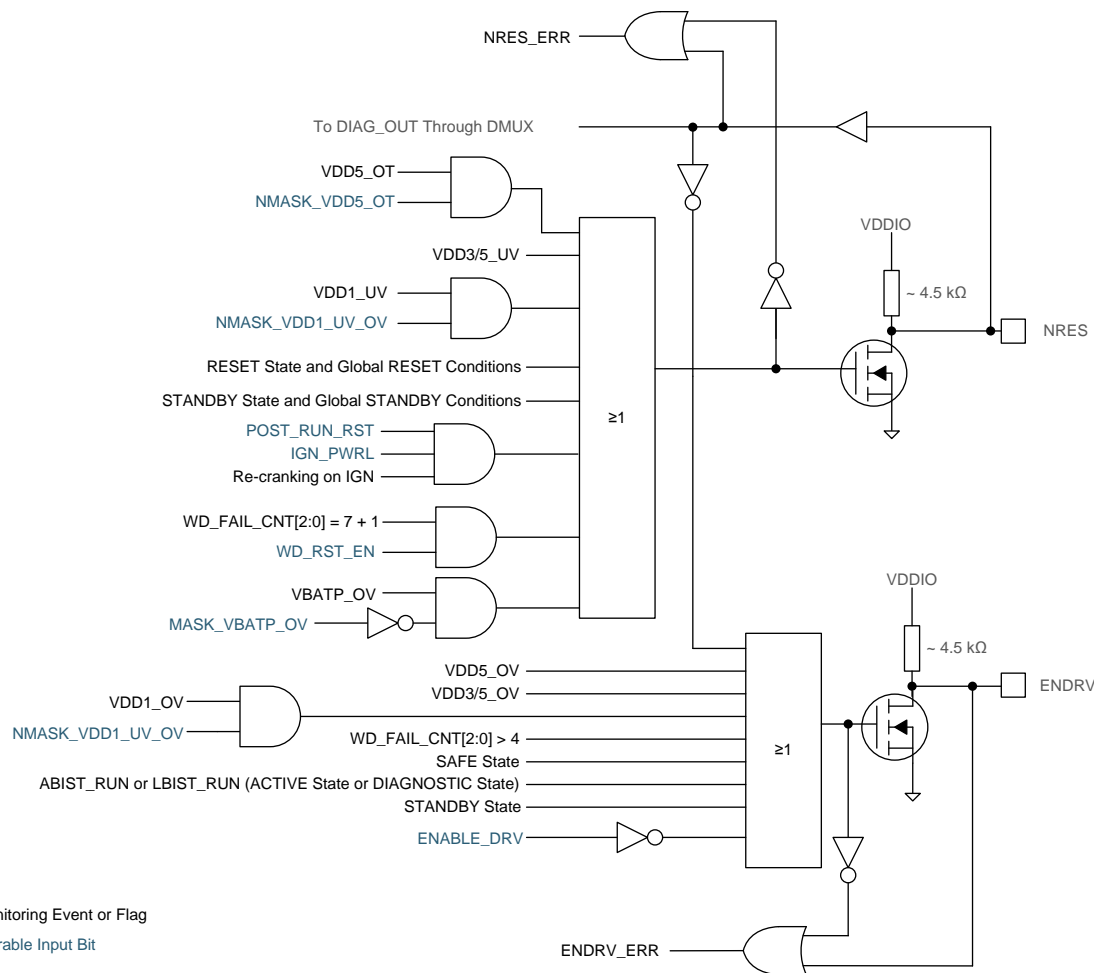

**Bit Type**  
 Status or Monitoring Event or Flag  
 User Configurable Input Bit

**Figure 5-14. Reset and Enable Circuit**

The ENDRV pin features a read-back circuit to compare the external ENDRV level with the internally applied ENDRV level. This feature detects any possible failure in the ENDRV pullup or pulldown components. A failure is detected by the MCU through the ENDRV\_ERR bit (bit 1 in the SAFETY\_STAT\_4 register).

The ENDRV pin is pulled low for the ABIST duration time (approximately 300 μs) when activating the ABIST function after the ENDRV output is turned on and driven high. This is part of ENDRV diagnostics to validate all monitoring functions that disable the ENDDRV output and confirm that the ENDRV output is controllable by using the ENDRV read-back path.

The NRES pin features a readback of the external NRES level. The value is read on the DIAG\_OUT pin and NRES\_ERR bit (bit 5 in the SAFETY\_STAT\_3 register)..

For both the ENDRV pin and the NRES pin, the logic read-back threshold level is typically 400 mV.

Figure 5-15 shows the timing-response diagram for the NRES and ENDRV pins to any VDDx undervoltage or overvoltage condition.

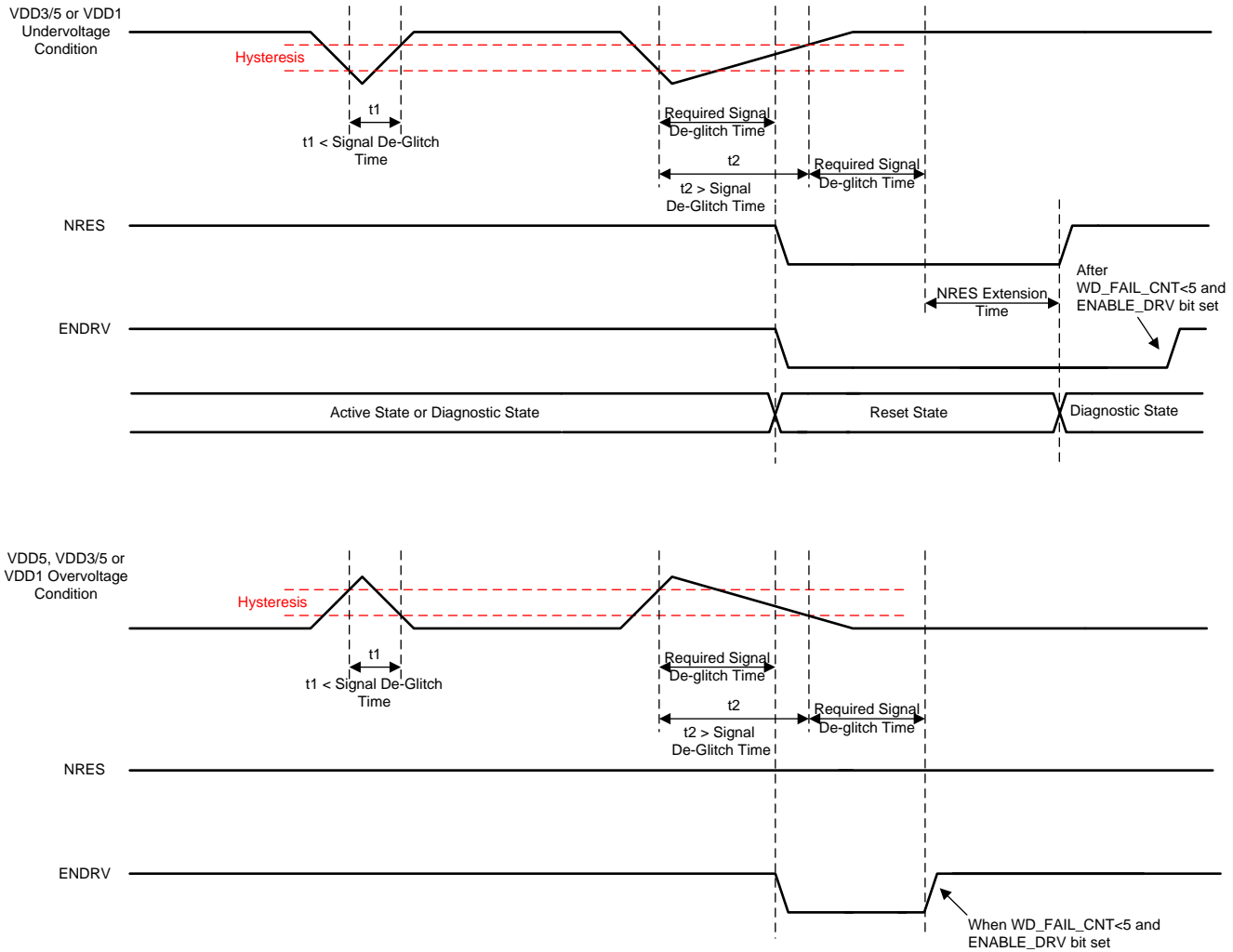

- (1) The signal deglitch time is defined for each undervoltage or overvoltage condition as given in [Section 4](#).
- (2) The NRES extension time is defined by the external resistor value as given in [Section 4](#).

**Figure 5-15. Timing-Response Diagram for NRES and ENDRV Pins to any VDDx Undervoltage or Overvoltage Condition**

5.4.19 Device Operating States

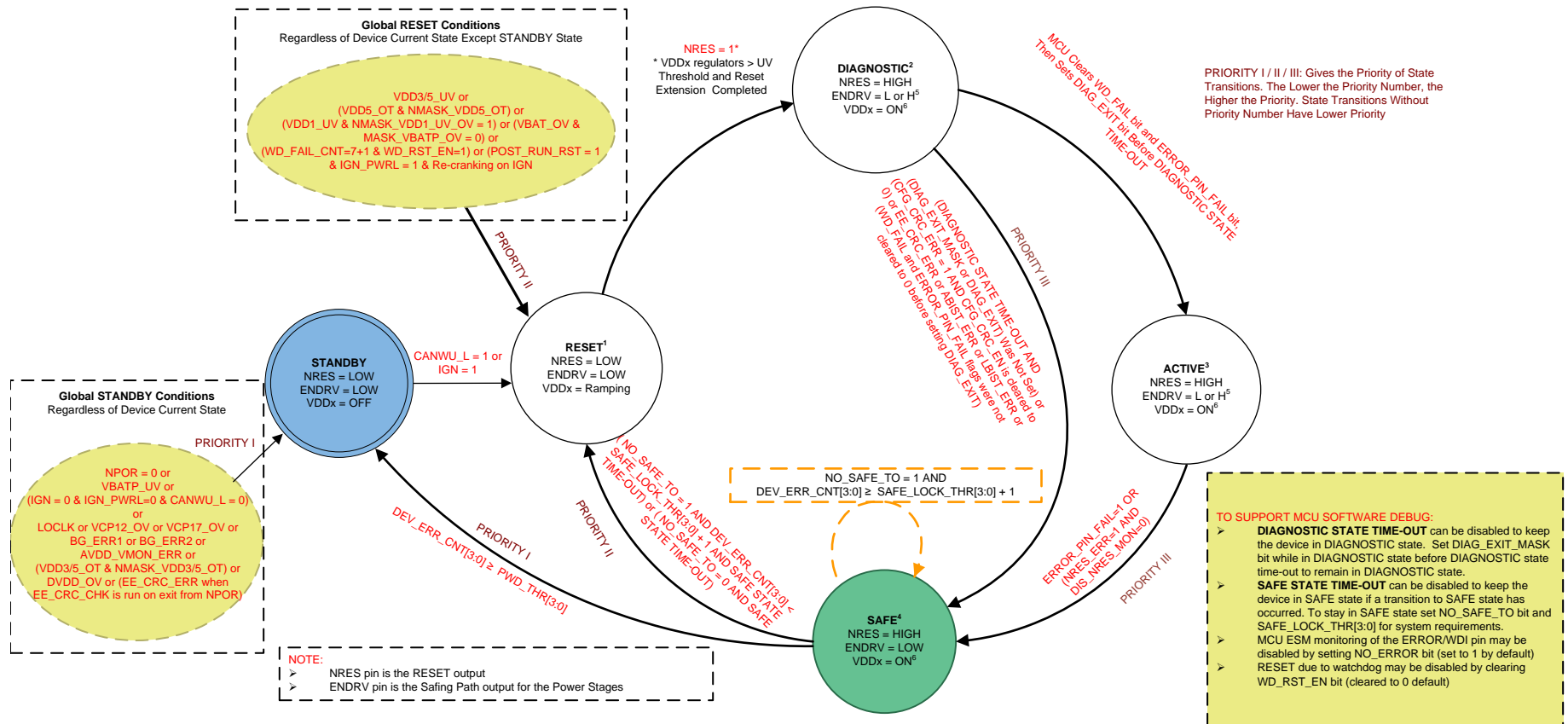

- (1) RESET State: SPI, Watchdog and MCU ESM are in reset; see Section 5.4.21 section for conditions that prevent the wake up from the STANDBY state to the RESET state.
- (2) DIAGNOSTIC State: BIST (LBIST with ABIST) is initiated on the transition into the DIAGNOSTIC state. See Section 5.4.22 for options to disable automatic BIST run, the DIAGNOSTIC state time-out and diagnostics the MCU may perform on safety functions. WD\_FAIL\_CNT reinitializes to 5 on transition into the DIAGNOSTIC state.
- (3) ACTIVE State: WD\_FAIL\_CNT reinitializes to 5 during transition into the ACTIVE state. During the ACTIVE state the MCU may perform diagnostics of some safety functions, see Section 5.4.23 for more details.
- (4) SAFE State: DEV\_ERR\_CNT[3:0] increments on any transition to the SAFE state. See Section 5.4.24 for details on SAFE state time-out.
- (5) The ENDRV pin level is dependent on the ENABLE\_DRV bit, WD\_FAIL\_CNT[2:0] counter value, and VDDx\_OV as shown in Figure 5-14 in the DIAGNOSTIC and ACTIVE states.
- (6) The VDD5 and VSOUT1 regulators may be enabled or disabled in the DIAGNOSTIC, ACTIVE, and SAFE states.

Figure 5-16. Device Controller State Diagram

### 5.4.20 STANDBY State

The STANDBY state is the default state when the device is supplied by the VBATP and VBAT\_SAFING supplies. This state has the characteristics that follow:

- All regulators are disabled
- The NRES and ENDRV pins are low.
- The device transitions to the STANDBY state from any state because of the following:
  - Internal power-on reset event (NPOR = 0)
  - VBATP undervoltage event (VBATP\_UV)
  - Deglitched IGN = 0 and IGN\_PWRL = 0 (cleared IGN power-latch control bit) and CANWU\_L = 0
  - Loss-of-clock detection (LOCLK)
  - VDD3/5 overtemperature event (VDD3/5\_OT) while NMASK\_VDD3/5\_OT = 1
  - DVDD undervoltage event (DVDD\_UV)
  - DVDD overvoltage event (DVDD\_OV)
  - AVDD\_VMON overvoltage or undervoltage event (AVDD\_VMON\_ERR)
  - VCP12 overvoltage event (VCP12\_OV)
  - VCP17 overvoltage event (VCP17\_OV)
  - Error with band gaps: BG\_ERR1 or BG\_ERR2
  - EEPROM check fails during run after exit from NPOR event (EE\_CRC\_ERR = 1 when EE\_CRC\_CHK is run on exit from NPOR)
  - The device error count (DEV\_ERR\_CNT[3:0]) is greater than or equal to the programmed power-down threshold, PWD\_THR[3:0]

### 5.4.21 RESET State

The RESET state has the characteristics that follow:

- This state is entered from the STANDBY state after a wake-up request from ignition (IGN pin = high, deglitched IGN bit = 1) or CANWU pin (CANWU pin = high, deglitched and latched CANWU\_L bit = 1). The following conditions would prevent the transition from the STANDBY state to the RESET state even if a wake-up request occurred:
  - BG\_ERR1
  - BG\_ERR2
  - VCP17\_OV
  - VCP12\_OV
  - AVDD\_VMON\_ERR
  - EE\_CRC\_CHK fails
- This state is entered from the SAFE state after a SAFE state time-out occurs and the DEV\_ERR\_CNT[3:0] counter is less than the programmed SAFE\_LOCK\_THR[3:0] + 1. See [Section 5.4.24](#) for details on the SAFE state time-out duration which is set by the SAFE\_TO[2:0] and NO\_SAFE\_TO bits.
- The device transitions to the RESET state from any other state because of the following:
  - VDD3/5 undervoltage event (VDD3/5\_UV)
  - VDD5 overtemperature event (VDD5\_OT) when NMASK\_VDD5\_OT = 1
  - VDD1 undervoltage event (VDD1\_UV) when NMASK\_VDD1\_UV\_OV = 1 (not default)
  - VBATP overvoltage event (VBATP\_OV) when MASK\_VBATP\_OV = 0 (default)
  - Watchdog reset. A watchdog reset occurs after the watchdog fail counter (WD\_FAIL\_CNT[2:0]) has reached a value of 7 and another bad event occurs (7+1) which sets the WD\_FAIL flag when WD\_RST\_EN = 1 (not default)
  - POST\_RUN\_RST = 1 and IGN\_PWRL = 1 and a re crank (LOW followed by a valid HIGH) on IGN pin
- The VDDx regulators are powered on.

- The NRES and ENDRV pins are low.
- The SPI, watchdog, and MCU ESM are in reset.

#### 5.4.22 DIAGNOSTIC State

The DIAGNOSTIC state has the characteristics that follow:

- The DIAGNOSTIC state is entered from the RESET state after the VDDx regulators have ramped-up and the reset extension is complete
- The VDD5 (enabled by default) regulator can be disabled by the VDD5\_EN bit, and the VSOUT1 regulator can be enabled (disabled by default) by the VSOUT1\_EN bit.
- The NRES pin is HIGH.
- The state of the ENDRV pin is determined by the ENABLE\_DRV bit, WD\_FAIL\_CNT[2:0] counter value, and the overvoltage monitoring for the VDDx regulators (VDDx\_OV) as shown in [Figure 5-14](#).
- The watchdog and MCU error signal monitoring (ESM) functions can be configured and operated. The MCU ESM module does not cause a transition to the SAFE state from the DIAGNOSTIC state when an emulated failure on the ERROR/WDI pin is detected. This allows the MCU to run diagnostics on the MCU ESM and ERROR/WDI pin during the DIAGNOSTIC state.
- This state is where the MCU should perform all device self-tests and diagnostics (failures are induced to emulate internal failures and confirm detection).
- Upon entry of the DIAGNOSTIC state, the watchdog fail counter is reinitialized to 5.
- The BIST (LBIST with ABIST) is activated with the transition out of the RESET state into the DIAGNOSTIC including a power up event from the STANDBY state. This automatic BIST run can be disabled with the AUTO\_BIST\_DIS bit for cases when the RESET state was entered from the DIAGNOSTIC, ACTIVE, or SAFE state, but cannot be disabled when the RESET state was entered from the STANDBY state at power up.
- The BIST (LBIST with ABIST) is initiated on the transition to the DIAGNOSTIC state.
- During the DIAGNOSTIC state, the MCU can perform diagnostics of any safety function such as watchdog, MCU ESM, ERROR/WDI pin, DIAG\_MUX pin, and CRC on registers. Ti recommends running diagnostic checks at least every power-up cycle while in the DIAGNOSTIC state.

#### NOTE

**DIAGNOSTIC state time-out:** When the DIAGNOSTIC state is entered, if the DIAG\_EXIT\_MASK or DIAG\_EXIT bit is not set to 1 within 512 ms (typical), the DIAGNOSTIC state time-out interval expires, causing a transition to the SAFE state. This also sets both the ERROR\_PIN\_FAIL and WD\_FAIL bits in the SAFETY\_ERR\_STAT register and sets the mirror bits, MCU\_ERR and WD\_ERR, in the SAFETY\_STAT\_4 register. The device error count (DEV\_ERR\_CNT[3:0]) is incremented. Only the DIAG\_EXIT\_MASK or DIAG\_EXIT bit should be set in a single SPI write command to the SAFETY\_CHECK\_CTRL register. Setting the DIAG\_EXIT bit to 1 causes a transition to the ACTIVE state. Setting the DIAG\_EXIT\_MASK bit to 1 causes the device to remain in the DIAGNOSTIC state (only recommended for software debug).

---

**NOTE**

**DIAG\_EXIT\_MASK for software debug:** When the DIAG\_EXIT\_MASK bit is set to 1 before the DIAGNOSTIC state time-out interval expires, the device stays in the DIAGNOSTIC state until the bit is cleared. The DIAGNOSTIC state time-out timer remains free running in the background, but does not cause a state transition. When the DIAGNOSTIC state time-out interval has expired, the DIAG\_EXIT bit is set automatically (in addition to the DIAG\_EXIT\_MASK bit remaining set) and the device remains in the DIAGNOSTIC state. For a controlled transition to the ACTIVE state, TI recommends clearing the DIAG\_EXIT\_MASK bit and setting the DIAG\_EXIT bit with a single SPI write command to the SAFETY\_CHECK\_CTRL register. If both the DIAG\_EXIT\_MASK bit and DIAG\_EXIT bits are cleared at the same time, the device remains in the DIAGNOSTIC state until either the next DIAGNOSTIC state time-out interval expires causing a transition to the SAFE state or if the DIAG\_EXIT bit is set to 1, prior to the DIAGNOSTIC state time-out, transitioning the device to ACTIVE state.

---

**NOTE**

In the DIAGNOSTIC state the following considerations must be considered if a manual run of the LBIST is initiated by setting the LBIST\_EN bit to 1. Setting the LBIST\_EN bit to 1 clears the DIAG\_EXIT\_MASK bit to 0. If the DIAG\_EXIT\_MASK bit is being used to hold the device in the DIAGNOSTIC state for software debug, it must be set again to 1 after LBIST completion to stay in the DIAGNOSTIC state. The DIAGNOSTIC state time-out counter stops only during the running of LBIST. After the LBIST completes, the time-out counter continues from the last value. For a transition from the DIAGNOSTIC state to the ACTIVE state, the DIAG\_EXIT bit must be set to 1.

---

### 5.4.23 ACTIVE State

The ACTIVE state has the characteristics that follow:

- The device enters from the DIAGNOSTIC state after the MCU sets the DIAG\_EXIT bit after clearing the ERROR\_PIN\_FAIL and WD\_FAIL bits.
- 

**NOTE**

While in the DIAGNOSTIC state, the MCU must clear by writing a 0 to the ERROR\_PIN\_FAIL bit and the WD\_FAIL bit in the SAFETY\_ERR\_STAT register before setting the DIAG\_EXIT bit. Clearing these bits also clears their mirror bits, MCU\_ERR and WD\_ERR. Otherwise, a transition to the SAFE state occurs.

---

- The NRES pin is high.
- The state of the ENDRV pin is determined by the ENABLE\_DRV bit, WD\_FAIL\_CNT[2:0] counter value, and the overvoltage monitoring for the VDDx regulators (VDDx\_OV) as shown in [Figure 5-14](#);
- The VDDx regulators are on, the VDD5 regulator can be enabled or disabled through the VDD5\_EN bit. The VSOUT1 regulator can be enabled or disabled through the VSOUT1\_EN bit.
- The WD\_FAIL\_CNT[2:0] counter reinitializes to 5 during a transition from the DIAGNOSTIC state to the ACTIVE state.
- The watchdog and MCU ESM monitoring functions are operated as configured but cannot be reconfigured.
- During the ACTIVE state, the MCU can perform diagnostics of some safety function such as watchdog, DIAG\_MUX pin, ABIST (approximately 300  $\mu$ s, ENDRV pin will be low), LBIST (approximately 21 ms, ENDRV pin will be low), and CRC on registers depending on the system safety requirements.

---

**NOTE**

In the ACTIVE state the following considerations must be considered if a manual run of the LBIST is initiated by setting the LBIST\_EN bit to 1. The LBIST should only be run in the ACTIVE state if the system-safety timing requirements can allow the total 21-ms BIST time and the ENDRV pin being low for the 21-ms.

See [Section 5.4.7](#) for additional system considerations if LBIST is run in the ACTIVE state.

---

#### 5.4.24 SAFE State

The SAFE state has the characteristics that follow:

- The SAFE state is entered from:
  - The ACTIVE state by:
    - An error in the signal on the ERROR/WDI pin detected by the MCU ESM while enabled. This transition is because of an error in the MCU and sets the ERROR\_PIN\_FAIL flag.
    - A detected read-back error on the NRES pin which sets the NRES\_ERR flag while DIS\_NRES\_MON is cleared to 0 (1 in default state).
  - The DIAGNOSTIC state by:
    - After a DIAGNOSTIC state time-out event happens before the DIAG\_EXIT\_MASK bit is set to 1, keeping the device in the DIAGNOSTIC state or before the DIAG\_EXIT bit is set to 1 transitioning the device to ACTIVE.
  - CFG\_CRC\_ERR = 1 AND CFG\_CRC\_EN is cleared to 0
  - An EE\_CRC\_ERR is detected in the DIAGNOSTIC state.
  - An ABIST\_ERR or LBIST\_ERR is detected in the DIAGNOSTIC state.
  - The WD\_FAIL and ERROR\_PIN\_FAIL flags were not cleared to 0 before setting the DIAG\_EXIT bit while exiting the DIAGNOSTIC state.
- Every transition to the SAFE state increments the device error count, DEV\_ERR\_CNT[3:0].
- The device stays in the SAFE state when the NO\_SAFE\_TO bit is set to 1 (default state) and DEV\_ERR\_CNT[3:0] = SAFE\_LOCK\_THR[3:0] + 1. This allows for programming the MCU without causing a reset and transition to the RESET state because of the SAFE state time-out.
- The NRES pin is high.
- The ENDRV pin is low.
- The VDDx regulators are on, the VDD5 regulator can be enabled or disabled with the VDD5\_EN bit. The VSOUT1 regulator can be enabled or disabled with the VSOUT1\_EN bit.

---

**NOTE**

The SAFE state time-out and device configuration settings are used by the device state machine to determine what the device does after a transition to the SAFE state. Depending on the NO\_SAFE\_TO, PWD\_THR[3:0], SAFE\_LOCK\_THR[3:0], and DEV\_ERR\_CNT[3:0] bits, the device stays locked in the SAFE state, transitions to the RESET state, or transitions to STANDBY state. The SAFE state time-out duration is programmable through SAFE\_TO[2:0].

**NO\_SAFE\_TO = 1 (Default)**

- While  $DEV\_ERR\_CNT[3:0] < (SAFE\_LOCK\_THR[3:0] + 1)$  the time delay for the SAFE state time-out is programmed by the SAFE\_TO[2:0] bit. The delay is calculated by  $[(SAFE\_TO[2:0] \times 2) + 1] \times 22$  ms.
- The device remains locked in the SAFE state when  $DEV\_ERR\_CNT[3:0] \geq SAFE\_LOCK\_THR[3:0] + 1$ .

**NO\_SAFE\_TO = 0**

- While  $DEV\_ERR\_CNT[3:0] < (SAFE\_LOCK\_THR[3:0] + 1)$  the time delay for the SAFE state time-out is programmed by the SAFE\_TO[2:0] bits. The delay is calculated by  $[(SAFE\_TO[2:0] \times 2) + 1] \times 22$  ms.
- When  $DEV\_ERR\_CNT[3:0] \geq SAFE\_LOCK\_THR[3:0] + 1$ , the SAFE state time-out duration changes and the device transitions to the RESET state after approximately 680 ms.

If the PWD\_THR[3:0] threshold is used, the device transitions from the SAFE state to the STANDBY state when  $DEV\_ERR\_CNT[3:0] \geq PWD\_THR[3:0]$ . This transition has higher priority (PRIORITY I) than the path from the SAFE state to the RESET state (PRIORITY II) so if  $PWD\_THR[3:0] = SAFE\_LOCK\_THR[3:0] + 1$  the device transitions to the STANDBY state not the RESET state.

---

#### 5.4.25 State Transition Priorities

For all global or possible double-state transitions, the following priorities hold true:

1. Priority I: all conditions for STANDBY state transition
2. Priority II: all conditions for RESET state transition
3. Priority III: all conditions for SAFE state transition

All other state transitions have a lower priority compared to any of the state transitions listed with priority numbers.

#### 5.4.26 Power on Reset (NPOR)

The device goes through a power on reset (NPOR) which reinitializes all registers. The events that cause an NPOR are:

- Analog power on reset:
  - Loss-of-clock detection (LOCLK)
  - AVDD\_VMON overvoltage or undervoltage event (AVDD\_VMON\_ERR)
  - DVDD undervoltage event (DVDD\_UV)
  - DVDD overvoltage event (DVDD\_OV)

- Digital power on reset. These errors can cause a NPOR. If the detected fault duration is less than 6 ms, an NPOR may not occur. When the CANWU or IGN state is kept high, the device transitions to the RESET state because of the wake-up request. The registers on the post-BIST reinitialization list are reinitialized after BIST runs on the transition from the RESET state to the DIAGNOSTIC state (unless AUTO\_BIST\_DIS = 1, not default).
  - VBATP undervoltage event (VBATP\_UV)
  - VDD3/5 overtemperature event (VDD3/5\_OT) while NMASK\_VDD3/5\_OT = 1
  - AVDD undervoltage event (AVDD\_UV)
  - Error with the device VMON trim settings (VMON\_TRIM\_ERROR)
  - Error with band gaps: BG\_ERR1 or BG\_ERR2
  - VCP12 overvoltage event (VCP12\_OV)
  - VCP17 overvoltage event (VCP17\_OV)

## 5.5 Register Maps

### 5.5.1 Serial Peripheral Interface (SPI)

The primary communication between the device and the external the MCU is through a SPI bus which provides full-duplex communications in a master-slave configuration. The external MCU is always a SPI master, which sends command requests on the SDI pin and receives device responses on the SDO pin. The TPS65381-Q1 device is always a SPI slave device, which receives command requests and sends responses (status, measured values) to the external MCU over the SDO line.

- The SPI is a 4-pin interface.
  - NCS—SPI chip select (active-low)
  - SCLK—SPI clock
  - SDI—SPI slave-in and master-out (SIMO)
  - SDO—SPI slave-out and master-in (SOMI, three-state output)
- The SPI frame size is 16 bits.
- Speed is up to 6 Mbit/s.
- Commands and data are shifted MSB first, LSB last.
- The SDI line is sampled on the falling edge of SCLK.
- The SDO line is shifted out on the rising edge of SCLK.

The SPI communication starts with the NCS falling edge, and ends with the NCS rising edge. The NCS high level keeps the SPI slave interface in the reset state, and the SDO output is in the tri-state.

#### 5.5.1.1 SPI Command Transfer Phase

Table 5-15 shows the transfer frame format of SPI data during a command (write or read command)..

**Table 5-15. SPI Command Transfer Phase**

BIT	D7	D6	D5	D4	D3	D2	D1	D0
FUNCTION	CMD6	CMD5	CMD4	CMD3	CMD2	CMD1	CMD0	PARITY

**CMD[6:0]** Register write (WR) or read (RD) command

**PARITY** Parity bit for 7-bit command field

The SPI does not support back-to-back SPI frame operation. After each SPI command or read access, the NCS pin must transition from low-to-high before the next SPI transfer can start. The minimum time ( $t_{hlcs}$ ) between two SPI commands during which the NCS pin must remain high is 788 ns.

#### 5.5.1.2 SPI Data-Transfer Phase

Table 5-16 shows the transfer frame format of SPI data during a write access.

**Table 5-16. SPI Data-Transfer Phase**

BIT	D7	D6	D5	D4	D3	D2	D1	D0
FUNCTION	DATA7	DATA6	DATA5	DATA4	DATA3	DATA2	DATA1	DATA0

**DATA[7:0]** Data value for write access (8-bit)

The SPI does not support back-to-back SPI frame operation. After each SPI transfer, the NCS pin must go from low to high before the next SPI transfer can start. The minimum time ( $t_{hics}$ ) between two SPI commands during which the NCS pin must remain high is 788 ns.

### 5.5.1.3 Device Status Flag Byte Response

Table 5-17 shows the response frame format of the SPI data status during a command (write or read access).

**Table 5-17. Device Status Flag Byte Response**

BIT	R7	R6	R5	R4	R3	R2	R1	R0
FUNCTION	STAT[7]	STAT[6]	STAT[5]	STAT[4]	STAT[3]	STAT[2]	STAT[1]	STAT[0]

**STAT[7]**

1

**STAT[6]**

0

**STAT[5]**

1

**STAT[4]**

0

**STAT[3]** SPI WR access (during previous SPI frame-command phase)

**STAT[2]** SPI SDO error (during previous SPI frame)

**STAT[1]**

0

**STAT[0]** SPI errors including truncated SPI frames, SPI transfers with more than 16 bits, SPI transfers with undefined commands or SPI transfers with incorrect command parity (during previous SPI frame)

The status bits sent during the current SPI command are reflecting the status of the previous SPI command.

---

#### NOTE

If a reset to the MCU is asserted during a SPI frame transfer (causing a truncated SPI frame), these SPI error status bits are not cleared, but maintain the status according to the truncated previous SPI frame until a SPI read access.

---

#### NOTE

The SPI SDO error bit, STAT[2], may be inadvertently set when the NCS pin is high, the SDO pin is high, and a falling edge occurs on the SPICLK pin. This combination occurs most often when the device is used in a SPI bus with multiple SPI slaves. If all three of these conditions are met, the SDO error flag is set to 1 in the second SPI flag byte response of the following SPI communication with the TPS65381-Q1. The application software should mask out the SDO error flag if the device is used under these conditions. If a SPI SDO error is detected, the device accepts the SPI transfer because the detected error is on the output not the input for the SPI.

---

#### NOTE

For additional diagnostic coverage for SPI write transfers, the system software could perform a read of the register written and compare the returned value to the value that is expected after the write. Be aware some bits in some registers are not writable.

---

### 5.5.1.4 Device SPI Data Response

Table 5-18 shows the response frame format of the SPI device data during a write or read access.

Table 5-18. Device SPI Data Response

BIT	R7	R6	R5	R4	R3	R2	R1	R0
FUNCTION	R7	R6	R5	R4	R3	R2	R1	R0

R[7:0] Internal register value. All unused bits are cleared to 0.

### 5.5.1.5 SPI Frame Overview

Figure 5-17 shows an overview of a complete 16-bit SPI Frame:

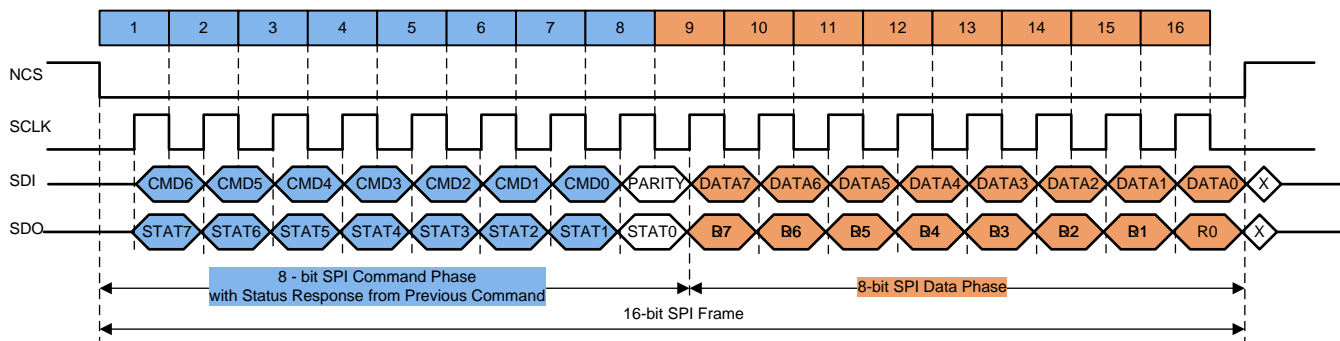

The SPI master (MCU) and SPI slave (TPS65381-Q1) sample receive data on the falling SCLK edge and transmit data on the rising SCLK edge.

Figure 5-17. 16-Bit SPI Frame

### 5.5.2 SPI Register Write Access Lock (SW\_LOCK command)

The SW\_LOCK command protects the SPI registers against write update access through MCU control. When the SW\_LOCK command with data AAh is sent to the device, the listed registers are locked from updates through a write access. To unlock the SPI registers, the SW\_UNLOCK command with data 55h is sent to the device.

**NOTE**

The SW\_LOCK command is in addition to the automatic locking of specific SPI registers against write update access except while the device is in DIAGNOSTIC state. Please see the SPI Command Table and the register descriptions to determine if SW\_LOCK and automatic locking except in DIAGNOSTIC state apply to specific write access registers.

### 5.5.3 SPI Registers (SPI Mapped Response)

The following sections list the SPI registers. For each SPI register, the bit names are given along with the initialized values (values after internal logic reset).

The values are initialized after each wake-up from the STANDBY state or after any other power-on reset (NPOR) event.

After a LBIST run is complete, including the LBIST run on the transition out of RESET state, the following functions and registers re-initialize:

- DEV\_STAT
- SAFETY\_STAT\_2
- SAFETY\_STAT\_4
- SAFETY\_STAT\_5 (but FSM[2:0] immediately updates to reflect the current device state)
- WD\_TOKEN\_VALUE

- WD\_STATUS
- SAFETY\_CHECK\_CTRL
- DIAG\_CFG\_CTRL
- DIAG\_MUX\_SEL

The initialized value of the reserved bits (RSV) is indicated, however some of these bits are used for internal device operation and the application software should mask them as they may not remain at their initialized value.

The following sections also list an explanation of each bit function.

**Table 5-19. SPI Command Table**

8-BIT HEX COMMAND CODE (WITH PARITY)	7-BIT HEX COMMAND CODE (WITHOUT PARITY)	7-BIT BINARY COMMAND CODE (WITHOUT PARITY)	PARITY	WR SW LOCK PROTECT	REGISTER COMMAND NAME <sup>(1)</sup>
BDh	5Eh	1011 110b	1	N/A	SW_LOCK with data AAh (to lock SPI WR access to listed registers)
BBh	5Dh	1011 101b	1	N/A	SW_UNLOCK with data 55h (to unlock SPI WR access to listed registers)
06h	03h	0000 011b	0	N/A	RD_DEV_ID
0Ch	06h	0000 110b	0	N/A	RD_DEV_REV
B7h	5Bh	1011 011b	1	YES	WR_DEV_CFG1 (SPI WR update can occur only in the DIAGNOSTIC state)
AFh	57h	1010 111b	1	N/A	RD_DEV_CFG1
95h	4Ah	1001 010b	1	YES	WR_DEV_CFG2 (SPI WR update can occur only in the DIAGNOSTIC state)
48h	24h	0100 100b	0	N/A	RD_DEV_CFG2
7Dh	3Eh	0111 110b	1	NO	WR_CAN_STBY (only valid with data 00h)
24h	12h	0010 010b	0	N/A	RD_SAFETY_STAT_1
C5h	62h	1100 010b	1	N/A	RD_SAFETY_STAT_2
A3h	51h	1010 001b	1	N/A	RD_SAFETY_STAT_3
A5h	52h	1010 010b	1	N/A	RD_SAFETY_STAT_4
C0h	60h	1100 000b	0	N/A	RD_SAFETY_STAT_5
30h	18h	0011 000b	0	N/A	RD_SAFETY_ERR_CFG
DBh	6Dh	1101 101b	1	YES	WR_SAFETY_ERR_CFG (SPI WR update can occur only in the DIAGNOSTIC state)
A9h	54h	1010 100b	1	YES	WR_SAFETY_ERR_STAT (SPI WR update can occur only in the DIAGNOSTIC state)
AAh	55h	1010 101b	0	N/A	RD_SAFETY_ERR_STAT
39h	1Ch	0011 100b	1	N/A	RD_SAFETY_PWD_THR_CFG
99h	4Ch	1001 100b	1	YES	WR_SAFETY_PWD_THR_CFG (SPI WR update can occur only in the DIAGNOSTIC state)
44h	22h	0100 010b	0	N/A	RD_SAFETY_CHECK_CTRL
93h	49h	1001 001b	1	NO	WR_SAFETY_CHECK_CTRL
3Ch	1Eh	0011 110b	0	N/A	RD_SAFETY_BIST_CTRL
9Fh	4Fh	1001 111b	1	YES	WR_SAFETY_BIST_CTRL
2Eh	17h	0010 111b	0	N/A	RD_WD_WIN1_CFG
EDh	76h	1110 110b	1	YES	WR_WD_WIN1_CFG (SPI WR update can occur only in the DIAGNOSTIC state)
05h	02h	0000 010b	1	N/A	RD_WD_WIN2_CFG
09h	04h	0000 100b	1	YES	WR_WD_WIN2_CFG (SPI WR update can occur only in the DIAGNOSTIC state)

(1) All commands have even parity.

Table 5-19. SPI Command Table (continued)

8-BIT HEX COMMAND CODE (WITH PARITY)	7-BIT HEX COMMAND CODE (WITHOUT PARITY)	7-BIT BINARY COMMAND CODE (WITHOUT PARITY)	PARITY	WR SW LOCK PROTECT	REGISTER COMMAND NAME <sup>(1)</sup>
36h	1Bh	0011 011b	0	N/A	RD_WD_TOKEN_VALUE
4Eh	27h	0100 111b	0	N/A	RD_WD_STATUS
E1h	70h	1110 000b	1	NO	WR_WD_ANSWER
11h	08h	0001 000b	1	N/A	RD_DEV_STAT
12h	09h	0001 001b	0	N/A	RD_VMON_STAT_1
A6h	53h	1010 011b	0	N/A	RD_VMON_STAT_2
56h	2Bh	0101 011b	0	N/A	RD_SENS_CTRL
7Bh	3Dh	0111 101b	1	N/A	WR_SENS_CTRL
3Ah	1Dh	0011 101b	0	N/A	RD_SAFETY_FUNC_CFG
35h	1Ah	0011 010b	1	YES	WR_SAFETY_FUNC_CFG (SPI WR update can occur only in the DIAGNOSTIC state)
5Ah	2Dh	0101 101b	0	N/A	RD_SAFETY_CFG_CRC
63h	31h	0110 001b	1	YES	WR_SAFETY_CFG_CRC (SPI WR update can occur only in the DIAGNOSTIC state)
DDh	6Eh	1101 110b	1	N/A	RD_DIAG_CFG_CTRL
CCh	66h	1100 110b	0	NO	WR_DIAG_CFG_CTRL
ACh	56h	1010 110b	0	N/A	RD_DIAG_MUX_SEL
C9h	64h	1100 100b	1	NO	WR_DIAG_MUX_SEL
D7h	6Bh	1101 011b	1	N/A	RD_SAFETY_ERR_PWM_H
D8h	6Ch	1101 100b	0	YES	WR_SAFETY_ERR_PWM_H (SPI WR update can occur only in the DIAGNOSTIC state)
59h	2Ch	0101 100b	1	N/A	RD_SAFETY_ERR_PWM_L
7Eh	3Fh	0111 111b	0	YES	WR_SAFETY_ERR_PWM_L (SPI WR update can occur only in the DIAGNOSTIC state)
78h	3Ch	0111 100b	0	N/A	RD_WD_TOKEN_FDBK
77h	3Bh	0111 011b	1	YES	WR_WD_TOKEN_FDBK (SPI WR update can occur only in the DIAGNOSTIC state)

5.5.3.1 Device Revision and ID

5.5.3.1.1 DEV\_REV Register

Initialization source: NPOR

Controller access: Read only (RD\_DEV\_REV)

Figure 5-18. DEV\_REV Register

D7	D6	D5	D4	D3	D2	D1	D0
REV[7]	REV[6]	REV[5]	REV[4]	REV[3]	REV[2]	REV[1]	REV[0]
0b	0b	1b	1b	0b	0b	0b	0b

- D[7:0] REV[7:0]: Device Revision
- REV[3:0]: Device minor revision
  - REV[7:4]: Device major revision

### 5.5.3.1.2 DEV\_ID Register

**Initialization source:** NPOR

**Controller access:** Read only (RD\_DEV\_ID)

**Figure 5-19. DEV\_ID Register**

D7	D6	D5	D4	D3	D2	D1	D0
ID[7]	ID[6]	ID[5]	ID[4]	ID[3]	ID[2]	ID[1]	ID[0]
0b	0b	0b	0b	0b	0b	0b	1b

**D[7:0]** ID[7:0]: Device ID

### 5.5.3.2 Device Status

#### 5.5.3.2.1 DEV\_STAT Register

**Initialization source:** NPOR, post LBIST reinitialization

**Controller access:** Read only (RD\_DEV\_STAT)

**Figure 5-20. DEV\_STAT Register**

D7	D6	D5	D4	D3	D2	D1	D0
RSV	RSV	RSV	RSV	RSV	RSV	CANWU_L	IGN
0b	0b	0b	0b	0b	0b	X	X

**D[7:2]** RSV

**D[1]** **CANWU\_L:** Latched CAN wake-up event

- The initialized value depends on whether a device wake-up event occurs through the CANWU or IGN pin.
- This bit clears to 0 when a device wake-up occurs through a CANWU, only a WR\_CAN\_STBY command, or any other global STANDBY condition

**D[0]** **IGN:** Deglitched IGN pin (7.5-ms to 22-ms deglitch time)

- The initialized value depends on whether a device wake-up event occurs through the CANWU or IGN pin. This bit follows the deglitched IGN signal, and therefore is only cleared to 0 when the deglitched IGN is low or by any other global STANDBY condition.

### 5.5.3.3 Device Configuration

#### 5.5.3.3.1 DEV\_CFG1 Register

**Initialization source:** NPOR

**Controller access:** Read (RD\_DEV\_CFG1)

Write (WR\_DEV\_CFG1). Write update can only occur in the DIAGNOSTIC state. Write access locked through SW\_LOCK command.

**Figure 5-21. DEV\_CFG1 Register**

D7	D6	D5	D4	D3	D2	D1	D0
VDD_3_5_SEL	NMASK_VDD1_UV_OV	RSV	RSV	RSV	RSV	RSV	RSV
X	0b	0b	0b	0b	0b	0b	0b

**D[7] VDD\_3\_5\_SEL:** Status bit of VDD3/VDD5 selection at power up

- SEL\_VDD3/5 input pin is sampled and latched at power up
  - 0b = 5-V setting (SEL\_VDD3/5 pin to ground)
  - 1b = 3.3-V setting (SEL\_VDD3/5 pin not connected)
  - Value in the RESET state depends on state of SEL\_VDD3/5 pin at first power up
- This bit is read only

**Note:** This bit is the same as the SAFETY\_FUNC\_CFG bit, D0)

**D[6] NMASK\_VDD1\_UV\_OV**

- Cleared to 0 by default:
  - Masked VDD1\_OV does not impact the ENDRV pin state
  - Masked VDD1\_UV does not impact the NRES pin state
- The default setting (0, masked) can be used in case the VDD1 regulator is not used in an application and the external power FET is not populated.

**Note:** If the VDD1 regulator is used in an application, TI recommends setting this bit to 1 when the device is in the DIAGNOSTIC state after the first start-up or power-up event.

**Note:** Even if this bit is set to 1, but the VDD1\_SENSE pin is externally floating, the pin is pulled up. The pullup condition is detected but the VDD1\_OV condition is masked and the ENDRV pin state is not impacted.

**D[5:0]** RSV

**5.5.3.3.2 DEV\_CFG2 Register**

**Initialization source:** NPOR

**Controller access:** Read (RD\_DEV\_CFG2)

Write (WR\_DEV\_CFG2). Write update can only occur in the DIAGNOSTIC state. Write access locked through SW\_LOCK command.

**Figure 5-22. DEV\_CFG2 Register**

D7	D6	D5	D4	D3	D2	D1	D0
NMASK_VDD3/5_OT	NMASK_VDD5_OT	MASK_VBATP_OV	POST_RUN_RST	RSV	RSV	RSV	RSV
1b	1b	0b	0b	0b	0b	0b	0b

**D[7] NMASK\_VDD3/5\_OT**

- When set to 1 (default), an overtemperature event on the VDD3/5 or VDD6 regulator disables the VDD3/5 regulator and the device goes to the STANDBY state. The VDD3/5\_OT flag sets in the SAFETY\_STAT\_1 register while an overtemperature event is detected.
- When cleared to 0, an overtemperature event on the VDD3/5 or VDD6 regulator disables the VDD3/5 regulator. When the VDD3/5 regulator reaches the UV level, the device goes to the RESET state. The VDD3/5\_OT flag is still set in the SAFETY\_STAT\_1 register while an overtemperature event is detected.

**D[6] NMASK\_VDD5\_OT**

- When set to 1 (default), an overtemperature event on the VDD5 regulator disables the VDD5 regulator and the device goes to the RESET state. The VDD5\_OT flag is set in the SAFETY\_STAT\_1 register while an overtemperature event is detected.
- When cleared to 0 the VDD5 overtemperature shutdown is disabled and the VDD5 regulator remains enabled. The VDD5\_OT flag is still set in the SAFETY\_STAT\_1 register while an overtemperature event is detected.

**D[5] MASK\_VBATP\_OV**

- Cleared to 0 by default.
- When set to 1, the VBATP\_OV bit is masked from the RESET condition.

**D[4] POST\_RUN\_RST:**

- Cleared to 0 per default.
- When set to 1, while using the IGN\_PWRL function, a recracking on the IGN pin causes the device to go to the RESET state.

**D[3:0] RSV** (bits are readable and writable in the DIAGNOSTIC state with no impact to device state or the ENDRV and NRES output)

## 5.5.4 Device Safety Status and Control Registers

### 5.5.4.1 VMON\_STAT\_1 Register

**Initialization source:** NPOR

**Controller access:** Read only (RD\_VMON\_STAT\_1)

**Figure 5-23. VMON\_STAT\_1 Register**

D7	D6	D5	D4	D3	D2	D1	D0
VBATP_OV	VBATP_UV	VCP17_OV	VCP12_OV	VCP12_UV	AVDD_VMON_ERR	BG_ERR2	BG_ERR1
0b	0b	0b	0b	0b	0b	0b	0b

- D[7] VBATP\_OV:** VBATP overvoltage status bit
  - Set to 1 when a VBATP overvoltage condition is detected
  - Cleared to 0 if an overvoltage condition is no longer present
- D[6] VBATP\_UV:** VBATP undervoltage status bit
  - Set to 1 when a VBATP undervoltage condition is detected
  - Cleared to 0 if an undervoltage condition is no longer present
- D[5] VCP17\_OV:** VCP17 overvoltage status bit
  - Set to 1 when a VCP17 overvoltage condition is detected
  - Cleared to 0 if an overvoltage condition is no longer present
- D[4] VCP12\_OV:** VCP12 overvoltage status bit
  - Set to 1 when a VCP12 overvoltage condition is detected
  - Cleared to 0 if an overvoltage condition is no longer present
- D[3] VCP12\_UV:** VCP12 undervoltage status bit
  - Set to 1 when a VCP12 undervoltage condition is detected
  - Cleared to 0 if an undervoltage condition is no longer present
- D[2] AVDD\_VMON\_ERR:** voltage-monitor power-supply power-good status
  - Set to 1 when voltage-monitor power supply is not OK.
  - Cleared to 0 if an error condition is no longer present
- D[1] BG\_ERR2:** Reference band-gap 2 error
  - Set to 1 when the voltage monitor is less than the main band gap
  - Cleared to 0 if an error condition is no longer present
- D[0] BG\_ERR1:** Reference band-gap 1 error
  - Set to 1 when the voltage monitor is greater than the main band gap
  - Cleared to 0 if an error condition is no longer present

### 5.5.4.2 VMON\_STAT\_2 Register

**Initialization source:** NPOR

**Controller access:** Read (RD\_VMON\_STAT\_2)

**Figure 5-24. VMON\_STAT\_2 Register**

D7	D6	D5	D4	D3	D2	D1	D0
VDD6_OV	VDD6_UV	VDD5_OV	VDD5_UV	VDD3/5_OV	VDD3/5_UV	VDD1_OV	VDD1_UV
0b	0b	0b	0b	0b	0b	0b	0b

**D[7] VDD6\_OV:** VDD6 overvoltage status bit

- Set to 1 when a VDD6 overvoltage condition is detected
- Cleared to 0 if an overvoltage condition is no longer present

**D[6] VDD6\_UV:** VDD6 undervoltage status bit

- Set to 1 when a VDD6 undervoltage condition is detected
- Cleared to 0 if an undervoltage condition is no longer present

**D[5] VDD5\_OV:** VDD5 overvoltage status bit

- Set to 1 when a VDD5 overvoltage condition is detected
- Cleared to 0 if an overvoltage condition is no longer present

**D[4] VDD5\_UV:** VDD5 undervoltage status bit

- Set to 1 when a VDD5 undervoltage condition is detected.
- Cleared to 0 if an undervoltage condition is no longer present

**Note:** This status bit reflects the undervoltage status even if the VDD5\_EN bit in the SENS\_CTRL register has been cleared to 0. If the VDD5 regulator is disabled, when the VDD5 regulator discharges and an undervoltage condition is detected, the VDD5\_UV bit is set to 1.

**D[3] VDD3/5\_OV:** VDD3/5 overvoltage status bit

- Set to 1 when a VDD3/5 overvoltage condition is detected
- Cleared to 0 if an overvoltage condition is no longer present

**D[2] VDD3/5\_UV:** VDD3/5 undervoltage status bit

- Set to 1 when a VDD3/5 undervoltage condition is detected
- Cleared to 0 if an undervoltage condition is no longer present

**D[1] VDD1\_OV:** VDD1 overvoltage status bit

- Set to 1 when a VDD1 overvoltage condition is detected
- Cleared to 0 if an overvoltage condition is no longer present

**D[0] VDD1\_UV:** VDD1 undervoltage status bit

- Set to 1 when a VDD1 undervoltage condition is detected
- Cleared to 0 if an undervoltage condition is no longer present

### 5.5.4.3 SAFETY\_STAT\_1 Register

**Initialization source:** NPOR

**Controller access:** Read (RD\_SAFETY\_STAT\_1)

**Figure 5-25. SAFETY\_STAT\_1 Register**

D7	D6	D5	D4	D3	D2	D1	D0
VDD5_ILIM	VDD3/5_ILIM	VSOUT1_UV	VSOUT1_OV	RSV	VSOUT1_OT	VDD5_OT	VDD_3_5_OT
0b	0b	0b	0b	0b	0b	0b	0b

**D[7] VDD5\_ILIM:** VDD5 current-limit status bit

- Set to 1 when a VDD5 current-limit condition is exceeded
- Cleared to 0 if a current-limit condition is no longer present

**Note:** This status bit is valid only when the VDD5\_EN bit in SENS\_CTRL register is set to 1. When the VDD5\_EN bit is cleared to 0, this bit will be 1.

**D[6] VDD3/5\_ILIM:** VDD3 current-limit status bit

- Set to 1 when a VDD3 current-limit condition is exceeded
- Cleared to 0 if a current-limit condition is no longer present

**D[5] VSOUT1\_UV:** Sensor-supply undervoltage status bit

- Set to 1 when a VSOUT1 undervoltage condition is detected
- Cleared to 0 if an undervoltage condition is no longer present

**D[4] VSOUT1\_OV:** Sensor-supply overvoltage status bit

- Set to 1 when a VSOUT1 overvoltage condition is detected
- Cleared to 0 if an overvoltage condition is no longer present

**D[3] RSV**

- This bit was previously the VSOUT1\_ILIM bit: VSOUT1 sensor-supply current-limit status bit
- Use diagnostic output pin, DIAG\_OUT, with the digital MUX setting for VSOUT1\_CL to monitor current-limit status for VSOUT1

**D[2] VSOUT1\_OT:** Sensor-supply overtemperature status bit

- Set to 1 when the VSOUT1 overtemperature condition is exceeded. This bit keeps the VSOUT1 regulator disabled as long as this bit is set.
- Cleared to 0 if an overtemperature condition is no longer present

**D[1] VDD5\_OT:** VDD5 overtemperature status bit

- Set to 1 when the VDD5 overtemperature condition is exceeded. When the NMASK\_VDD5\_OT bit is set 1, an overtemperature event disables the VDD5 regulator and clears the VDD5\_EN bit to 0 (SENS\_CTRL register). When the NMASK\_VDD5\_OT bit is 0, an overtemperature event sets the VDD5\_OT bit to 1 but no other device action is taken.
- Cleared to 0 if an overtemperature condition is no longer present

**D[0] VDD\_3\_5\_OT:** VDD3/5 overtemperature status bit

- Set to 1 when the VDD3/5 overtemperature condition is exceeded. This bit keeps VDD3/5 regulator disabled as long as this bit is set to 1.
- Cleared to 0 if an overtemperature condition is no longer present

#### 5.5.4.4 SAFETY\_STAT\_2 Register

**Initialization source:** NPOR, post LBIST reinitialization

**Controller access:** Read only (RD\_SAFETY\_STAT\_2)

**Figure 5-26. SAFETY\_STAT\_2 Register**

D7	D6	D5	D4	D3	D2	D1	D0
RSV	RSV	CFG_CRC_ER R	EE_CRC_ERR	RSV	WD_FAIL_CNT [2]	WD_FAIL_CNT [1]	WD_FAIL_CNT [0]
0b	0b	0b	0b	0b	1b	0b	1b

D[7:6] RSV

**D[5] CFG\_CRC\_ERR:** CRC error status bit for the safety configuration registers

- Safety configuration registers are protected by CRC8.
- This bit is set to 1 when the calculated CRC8 value for the safety configuration registers does not match the expected CRC8 value stored in the SAFETY\_CFG register.
- Cleared to 0 when a CRC8 mismatch is no longer present.
- Cleared to 0 when the EEPROM CRC performs without error (regardless of CFG\_CRC check result)

**D[4] EE\_CRC\_ERR:** EPROM CRC error status bit

- EEPROM content is protected by CRC8.
- This bit is set to 1 when the calculated CRC8 value does not match the expected CRC8 value stored in the EEPROM DFT register. When this bit is set to 1 and device is in the DIAGNOSTIC state, the device transitions to the SAFE state.
- Cleared to 0 when a CRC8 mismatch is no longer present.

D[3] RSV

**D[2:0] WD\_FAIL\_CNT[2:0]:** watchdog fail counter

- The default value is 5, and is initialized to this value upon entering the DIAGNOSTIC and ACTIVE state
- Watchdog fail counter increments every time the device watchdog detects a bad or time-out event and decrements each time a good event is received.
- Watchdog fail counter must decrease below 5 to enable the ENDRV pin.
- Watchdog fail is detected on the next bad or time-out event after the watchdog fail counter reached the count of 7 (that is 7+1) while the WD\_RST\_EN bit is set to 1. The WD\_FAIL status bit is set to 1 in the SAFETY\_ERR\_STAT register (setting the WD\_FAIL bit to 1 in the SAFETY\_ERR\_STAT register).

### 5.5.4.5 SAFETY\_STAT\_3 Register

**Initialization source:** NPOR

**Controller access:** Read only (RD\_SAFETY\_STAT\_3)

**Figure 5-27. SAFETY\_STAT\_3 Register**

D7	D6	D5	D4	D3	D2	D1	D0
RSV	RSV	NRES_ERR	LBIST_ERR	ABIST_ERR	ABIST_ERR	LBIST_RUN	ABIST_RUN
0b	0b	0b	0b	0b	0b	0b	0b

D[7:6] RSV

**D[5] NRES\_ERR:** Reset error input status

- This bit is set to 1 when a mismatch between the NRES pin output HIGH and the NRES pin input readback LOW is detected, regardless of the value of the DIS\_RES\_MON bit. Depending on the external RC loading of this pin and the timing to read this bit, it may be set to 1 briefly if the external RC delay slows a change in level that is longer than the internal deglitch time (120  $\mu$ s typical).
- Cleared to 0 if no failure is present anymore.
- The DIS\_NRES\_MON bit in the SAFETY\_FUNC\_CFG register determines if this error causes a state transition from the ACTIVE state to the SAFE state.

**D[4] LBIST\_ERR:** Logic BIST (LBIST) error-status bit

- This bit is set to 1 when the LBIST fails
- Cleared to 0 after a LBIST run is complete without failure
- Only valid when the LBIST\_RUN bit is 0

**D[3] ABIST\_ERR:** Analog BIST (ABIST) error-status bit

- This bit is set to 1 when the ABIST fails. If this bit is set to 1 and the device is in the DIAGNOSTIC state, the device transitions to the SAFE state.
- Cleared to 0 after a ABIST run is complete without failure
- Only valid when the ABIST\_RUN bit is 0 (ABIST is not running)

**D[2] ABIST\_ERR:** Analog BIST (ABIST) error-status bit (identical to D3)

- This bit is set to 1 when the ABIST fails. If this bit is set to 1 and device is in the DIAGNOSTIC state, the device transitions to the SAFE state.
- Cleared to 0 after a ABIST run is complete without failure
- Only valid when the ABIST\_RUN bit is 0 (ABIST is not running)

**D[1] LBIST\_RUN:** Logic BIST (LBIST) run status bit

- This bit is set to 1 when a LBIST is running.
- Cleared to 0 when the LBIST is not running.

**D[0] ABIST\_RUN:** Analog BIST (ABIST) run status bit

- This bit is set to 1 when the ABIST is running.
- Cleared to 0 when the ABIST is not running.

### 5.5.4.6 SAFETY\_STAT\_4 Register

**Initialization source:** NPOR, post LBIST reinitialization

**Controller access:** Read only (RD\_SAFETY\_STAT\_4)

**Figure 5-28. SAFETY\_STAT\_4 Register**

D7	D6	D5	D4	D3	D2	D1	D0
SPI_ERR[1]	SPI_ERR[0]	LOCLK	RSV	MCU_ERR	WD_ERR	ENDRV_ERR	TRIM_ERR_VMON
0b	0b	0b	0b	0b	0b	0b	0b

**D[7:6] SPI\_ERR[1:0]:** SPI error-status bits

00b = No error

01b = SPI SDO error (mismatch on SDO output)

If both a SPI SDO error and another SPI error occur during the same SPI frame, 01b is shown in the SPI\_ERR[1:0] bit because the SPI SDO error has priority.

10b = Reserved

11b = SPI errors including truncated SPI frames, SPI transfers with more than 16 bits, SPI transfers with undefined commands or SPI transfers with incorrect command parity

- Cleared to 0 after a SPI read access or any SPI frame with no errors.

**Note:** If a reset to the MCU is asserted during a SPI frame transfer (causing a truncated SPI frame), these SPI error status bits are not cleared, but maintain the status according to the truncated previous SPI frame until SPI read access

**D[5] LOCLK:** Loss of clock-detection status bit

- Set when a loss-of-clock failure is detected and also set after the ABIST is complete

- Cleared to 0 after internal NPOR and clear on read (after ABIST)

**D[4] RSV**

**D[3] MCU\_ERR:** MCU error signal monitor (MCU ESM) status bit

- This bit is set to 1 when the MCU ESM module detects an error on the ERROR/WDI pin while MCU ESM monitoring is enabled.

- This bit mirrors the ERROR\_PIN\_FAIL bit in the SAFETY\_ERR\_STAT register

**D[2] WD\_ERR:** Watchdog error-status bit

- This bit is set to 1 on the next bad or time-out event when the WD\_FAIL\_CNT[2:0] counter reaches a count of 7 (that is 7+1) when the WD\_RST\_EN bit (bit 3 in the SAFETY\_FUNC\_CFG) is set to 1. Also set to 1 when the DIAGNOSTIC state time-out occurs.

- This bit mirrors the WD\_FAIL bit in the SAFETY\_ERR\_STAT register

**D[1] ENDRV\_ERR:** Enable driver error

- This bit is set to 1 when a mismatch between the ENDRV pin output and the ENDRV input feedback is detected. Depending on the external RC loading of this pin and the timing to read this bit, it may be set to 1 briefly if the external RC delay slows a change in level that is longer than the internal deglitch time (32  $\mu$ s typical).

- Cleared to 0 if the failure is no longer present

**D[0] TRIM\_ERR\_VMON:** VMON trimming error-status bit

- This bit is set to 1 when mismatch voltage-monitor trim error is detected.

- Cleared to 0 after an internal NPOR and if failure is not present anymore.

### 5.5.4.7 SAFETY\_STAT\_5 Register

**Initialization source:** POR, post LBIST reinitialization  
**Controller access:** Read only (RD\_SAFETY\_STAT\_5)

**Figure 5-29. SAFETY\_STAT\_5 Register**

D7	D6	D5	D4	D3	D2	D1	D0
RSV	RSV	RSV	RSV	RSV	FSM[2]	FSM[1]	FSM[0]
0b	0b	0b	0b	0b	0b	1b	1b

- D[2:0] FSM[2:0]:** Current device state
- Reflects the current device state (the bits will immediately update to reflect the current device state after an NPOR or post LBIST reinitialization)
    - STANDBY state: 00h
    - RESET state: 03h
    - DIAGNOSTIC state: 07h
    - ACTIVE state: 05h
    - SAFE state: 04h

### 5.5.4.8 SAFETY\_ERR\_CFG Register

**Initialization source:** NPOR  
**Controller access:** Read (RD\_SAFETY\_ERR\_CFG)  
 Write (WR\_SAFETY\_ERR\_CFG). Write update can only occur in the DIAGNOSTIC state. Write access locked through SW\_LOCK command.

**Figure 5-30. Register**

D7	D6	D5	D4	D3	D2	D1	D0
SAFE_TO [2]	SAFE_TO [1]	SAFE_TO [0]	SAFE_LOCK_T HR [3]	SAFE_LOCK_T HR [2]	SAFE_LOCK_T HR [1]	SAFE_LOCK_T HR [0]	CFG_LOCK
0b	0b	0b	0b	0b	0b	0b	0b

- D[7:5] SAFE\_TO[2:0]:** SAFE state time-out settings
- Duration of the SAFE state is time-limited to protect against potential MCU *locked* state.
  - Time-out duration =  $(2 \times \text{SAFE\_TO}[2:0] + 1) \times 22 \text{ ms}$
  - Minimum duration is 22 ms
  - Maximum duration is 330 ms
  - 22-ms time reference has 5% accuracy coming from 4-MHz internal oscillator)
- D[4:1] SAFE\_LOCK\_THR[3:0]**
- Sets the corresponding device DEV\_ERR\_CNT[3:0] threshold at which device remains in the SAFE state regardless of SAFE state time-out event
  - When the NO\_SAFE\_TO bit (SAFETY\_FUNC\_CFG register, bit 7) is set to 1:
    - While  $\text{DEV\_ERR\_CNT}[3:0] < \text{SAFE\_LOCK\_THR}[3:0] + 1$ , SAFE state time-out transition time from the SAFE-to-RESET state is controlled through the SAFE\_TO[2:0] bit settings. SAFE state time-out duration is calculated  $(\text{SAFE\_TO}[2:0] \times 2 + 1) \times 22 \text{ ms}$
    - Device remains *locked* in the SAFE state when the DEV\_ERR\_CNT[3:0] counter reaches  $\text{SAFE\_LOCK\_THR}[3:0] + 1$  value.
  - When the NO\_SAFE\_TO bit (SAFETY\_FUNC\_CFG register, bit 7) is cleared to 0:
    - While  $\text{DEV\_ERR\_CNT}[3:0] < \text{SAFE\_LOCK\_THR}[3:0] + 1$ , time-out transition time from the SAFE-to-RESET state is controlled through the SAFE\_TO[2:0] bit settings. Time-delay duration is calculated  $(\text{SAFE\_TO}[2:0] \times 2 + 1) \times 22 \text{ ms}$
    - When the DEV\_ERR\_CNT[3:0] counter reaches  $\text{SAFE\_LOCK\_THR}[3:0] + 1$  value, the device transitions to the RESET state after 680 ms.
  - Intended to support software debug and development and is NOT recommended for normal functional operation.
  - The 0000b setting is the default setting, and has same effect as the 1111b setting. Both settings give the minimum threshold.
- D[0] CFG\_LOCK**
- Register lock access control
  - When set to 1, the register content cannot be updated by SPI WR access.

### 5.5.4.9 SAFETY\_BIST\_CTRL Register

**Initialization source:** NPOR

**Controller access:** Read (RD\_SAFETY\_BIST\_CTRL)

Write (WR\_SAFETY\_BIST\_CTRL). Write access locked through SW\_LOCK command.

**Figure 5-31. SAFETY\_BIST\_CTRL Register**

D7	D6	D5	D4	D3	D2	D1	D0
BIST_DEG_CN T[1]	BIST_DEG_CN T[0]	AUTO_BIST_DI S	EE_CRC_CHK	RSV	LBIST_EN	ABIST_EN	ABIST_EN
0b	0b	0b	0b	0b	0b	0b	0b

**D[7:6] BIST\_DEG\_CNT[1:0]:** Deglitch filter duration setting during an active ABIST

- This bit controls the deglitch filter duration for every safety monitored voltage.
- Resolution is 15  $\mu$ s (with the minimum setting at 15  $\mu$ s and the maximum setting at 60  $\mu$ s):  $\text{bist\_deglitch} = (\text{BIST\_DEG\_CNT}[1:0] + 1) \times 15 \mu\text{s}$
- 15- $\mu$ s time reference has 5% accuracy coming from 4-MHz internal oscillator.
- When the ABIST is run in the ACTIVE state, TI recommends to set this to the maximum deglitch time

**D[5] AUTO\_BIST\_DIS**

- This bit controls the automatic BIST run on the transition from the RESET to the DIAGNOSTIC state ONLY when the device enters the RESET state from the DIAGNOSTIC, ACTIVE, or SAFE state.
- When set to 1, automatic BIST run is, except for the automatic BIST run on power up from the STANDBY state

**D[4] EE\_CRC\_CHK:** Recalculate EEPROM CRC8

- This bit controls the EEPROM CRC8 check function
- When set to 1, the EEPROM content is reloaded and CRC8 re-calculated and compared against expected value stored in EEPROM DFT register.

**Note:** With every power-up event, EEPROM content is reloaded and its CRC8 recalculated.

- The self-test status is checked through bit 4 in the SAFETY\_STAT\_2 register.

**D[3] RSV,** readable and writable without effect

**D[2] LBIST\_EN:** Enables LBIST run

- This bit controls the LBIST run (which also runs the ABIST)
- The self-test status is monitored through the D1 and D4 bits in the SAFETY\_STAT\_3 register.
- The LBIST\_EN bit clears the DIAG\_EXIT\_MASK bit to 0. The DIAGNOSTIC state time-out counter only stops during the running of the LBIST. After the LBIST is complete, the time-out counter continues from the last value. To stay in the DIAGNOSTIC state, the DIAG\_EXIT\_MASK bit must be set to 1 after LBIST completion. For a transition from the DIAGNOSTIC state to the ACTIVE state, the DIAG\_EXIT bit must be set to 1.

**D[1] ABIST\_EN:** Enable ABIST run (same as D[0])

- This bit controls the analog UV,OV and LOC BIST run.
- The self-test status is monitored through the D0, D2, and D3 bits in the SAFETY\_STAT\_3 register, and the D5 bit in the SAFETY\_STAT4 register.

**D[0] ABIST\_EN:** Enable analog BIST run (same as D[1])

- The bit controls the analog UV, OV, and LOC BIST run.
- The self-test status is monitored through the D0, D2, and D3 bits in the SAFETY\_STAT\_3 register, and the D5 bit in the SAFETY\_STAT4 register.

### 5.5.4.10 SAFETY\_CHECK\_CTRL Register

**Initialization source:** NPOR, post LBIST reinitialization  
**Controller access:** Read (RD\_SAFETY\_CHECK\_CTRL)  
 Write (WR\_SAFETY\_CHECK\_CTRL). .

**Figure 5-32. SAFETY\_CHECK\_CTRL Register**

D7	D6	D5	D4	D3	D2	D1	D0
CFG_CRC_EN	RSV	ENABLE_DRV	RSV	RSV	NO_ERROR	DIAG_EXIT_MASK	DIAG_EXIT
0b	0b	0b	1b	0b	1b	0b	0b

**D[7] CFG\_CRC\_EN**

- This bit controls the enabling of CRC8 protection for the device configuration registers.
- When set to 1, the CRC8 is calculated for all device configuration registers and compared with the CRC8 value stored in the SAFETY\_CFG\_CRC register.
- TI recommends to first set the desired device configuration, followed by updating the SAFTY\_CFG\_CRC register before setting this bit to 1.
- The following registers are protected:
  - SAFETY\_FUNC\_CFG register
  - DEV\_REV (device revision) register
  - SAFETY\_PWD\_THR\_CFG register
  - SAFETY\_ERR\_CFG register
  - WD\_TOKEN\_CFG register
  - WD\_WIN1\_CFG register
  - WD\_WIN2\_CFG register
  - SAFETY\_ERR\_PWM\_L register
  - DEV\_CFG2 register
  - DEV\_CFG1 register (only the D6 bit)

D[6] RSV, readable and writeable with no impact to device state or the ENDRV, and NRES output

**D[5] ENABLE\_DRV**

- Controls the enabling of the ENDRV output
- In addition to setting this bit to 1, the watchdog fail counter must be decremented below the default count value of 5 to enable the ENDRV output.

D[4:3] RSV, readable and writeable with no impact to device state or the ENDRV, and NRES output

**D[2] NO\_ERROR**

- This bit enables MCU ESM monitoring of the ERROR/WDI pin. When enabled the MCU ESM transitions the device from the ACTIVE state to the SAFE state when an error is detected.
  - 0b = MCU ESM is enabled and the ERROR/WDI pin is monitored. A detected failure in the ACTIVE state causes a transition to the SAFE state, a detected failure in the DIAGNOSTIC state does not cause a transition to the SAFE state.
  - 1b = MCU ESM is not enabled and the ERROR/WDI pin is not monitored and a failure in the ACTIVE state does not cause a transition to the SAFE state.
- If a failure is detected when NO\_ERROR = 0 (MCU ESM is enabled).
  - The ERROR\_PIN\_FAIL status bit in the SAFETY\_ERR\_STAT register is set
  - The MCU\_ERR status bit in the SAFETY\_STAT\_4 register is set

**D[1] DIAG\_EXIT\_MASK**

- Controls the exit from the DIAGNOSTIC state
- When set to 1, exit from the DIAGNOSTIC state is disabled regardless if a DIAGNOSTIC state time-out event occurs or if the DIAG\_EXIT bit is set.
- This feature is only recommended for software debug and development and must not be activated in functional mode.

**D[0] DIAG\_EXIT**

- Controls exit from the DIAGNOSTIC state to the ACTIVE state
- When set to 1 and the DIAG\_EXIT\_MASK bit is 0, the device transitions from the DIAGNOSTIC to the ACTIVE state.

### 5.5.4.11 SAFETY\_FUNC\_CFG Register

**Initialization source:** NPOR

**Controller access:** Read (RD\_SAFETY\_FUNC\_CFG)

Write (WR\_SAFETY\_FUNC\_CFG). Write update can only occur in the DIAGNOSTIC state. Write access locked through SW\_LOCK command.

**Figure 5-33. SAFETY\_FUNC\_CFG Register**

D7	D6	D5	D4	D3	D2	D1	D0
NO_SAFE_TO	ERROR_CFG	WD_CFG	IGN_PWRL	WD_RST_EN	DIS_NRES_MON	RSV	VDD_3_5_SEL
1b	0b	0b	0b	0b	1b	0b	X

**D[7] NO\_SAFE\_TO**

- Controls the enabling and disabling of the SAFE state time-out function
  - When set to 1: The SAFE state time-out is disabled. The device remains *locked* in the SAFE state when the DEV\_ERR\_CNT[3:0] counter reaches the SAFE\_LOCK\_THR[3:0] + 1 value.
  - When cleared to 0: The SAFE state time-out is enabled. The device transitions to the RESET state after 680 ms when the DEV\_ERR\_CNT[3:0] counter reaches the SAFE\_LOCK\_THR[3:0] + 1 value.

**D[6] ERROR\_CFG: MCU ESM configuration bit**

- When cleared to 0: PWM Mode is selected (can be used as an external clock monitor). The expected ERROR/WDI pin LOW and HIGH durations are controlled by the SAFETY\_ERR\_PWM\_H and SAFETY\_ERR\_PWM\_L registers (see [Section 5.5.4.14](#), respectively).
- When set to 1: The TMS570 mode is selected. The ERROR pin low-duration threshold is set by the SAFETY\_ERR\_PWM\_L register.
- Use the NO\_ERROR bit in the SAFETY\_CHECK\_CTRL register to enable the MCU ESM function

**D[5] WD\_CFG: Watchdog function configuration bit**

- When cleared to 0: Trigger mode (default) – watchdog trigger input through the ERROR/WDI pin
- When set to 1: Q&A mode – watchdog answers input through SPI

**D[4] IGN\_PWRL: Ignition-power latch control bit**

- Controls the enabling of the ignition-power latch
  - Note:** This bit can only be changed when the device is in the DIAGNOSTIC state
- When cleared to 0: With the IGN pin LOW, the device enters the STANDBY state. Cleared by a CANWU event
- When set to 1: The IGN pin can be pulled LOW, but the device remains powered up.

**D[3] WD\_RST\_EN**

- 1b = Enables a transition to the RESET state when a Watchdog failure is detected (the WD\_FAIL\_CNT[2:0] counter reaches the count of 7+1).
- 0b (default) = Disables a transition to the RESET state when watchdog failure events are detected (the WD\_FAIL\_CNT[2:0] counter reaches the count of 7 + 1).

**D[2] DIS\_NRES\_MON**

- When cleared to 0: In the ACTIVE state, a difference between the read-back level on the NRES pin and the NRES pin output driver state causes a transition to the SAFE state and the NRES\_ERR bit is set.
- When set to 1 (default state): State transition because of a difference between the read-back NRES pin level and the NRES driver state is disabled. (default state) **Note:** The NRES\_ERR bit is still set if a difference between the read-back NRES pin level and the NRES driver state is detected.

**D[1] RSV, readable and writeable in the DIAGNOSTIC state with no impact to the device state or the ENDRV and NRES output**

**D[0] VDD\_3\_5\_SEL: Status bit of VDD3/VDD5 selection at power up**

- The SEL\_VDD3/5 input pin is sampled and latched at power up
  - 0b = 5-V setting (pin SEL\_VDD3/5 connected to ground)
  - 1b = 3.3-V setting (the SEL\_VDD3/5 pin is not connected)
  - Value in the RESET state depends on the state of the SEL\_VDD3/5 pin at first power up
- This bit is read only

**Note:** This bit is the same as the DEV\_CFG1 bit, D7

### 5.5.4.12 SAFETY\_ERR\_STAT Register

**Initialization source:** NPOR

**Controller access:** Read (RD\_SAFETY\_ERR\_STAT)

Write (WR\_SAFETY\_ERR\_STAT). Write update can only occur in the DIAGNOSTIC state. Write access locked through SW\_LOCK command.

**Figure 5-34. SAFETY\_ERR\_STAT Register**

D7	D6	D5	D4	D3	D2	D1	D0
RSV	RSV	ERROR_PIN_FAIL	WD_FAIL	DEV_ERR_CNT T[3]	DEV_ERR_CNT T[2]	DEV_ERR_CNT T[1]	DEV_ERR_CNT T[0]
0b	0b	0b	0b	0b	0b	0b	0b

D[7:6] RSV

**D[5] ERROR\_PIN\_FAIL**

- Set to 1 when the MCU ESM Module detects a failure on the ERROR/WDI pin, only if NO\_ERROR = 0 (bit D2 in SAFETY\_CHECK\_CTRL register). The device enters the SAFE state when this ERROR\_PIN\_FAIL bit is set to 1 while the device is in the ACTIVE state and NO\_ERROR = 0. Also set to 1 when a DIAGNOSTIC state time-out occurs.
- Cleared by using SPI to write a 0 to the bit or cleared to 0 during reset event. **Note:** in the DIAGNOSTIC state it is also possible to write this bit to 1, leaving it set at 1 will have the same device level impact as a detected failure on the ERROR/WDI pin.

**D[4] WD\_FAIL**

- This bit is set to 1 on the next bad event when the watchdog fail counter reaches a count of 7 (that is 7 + 1) (the WD\_FAIL\_CNT[2:0] bits in the SAFETY\_STAT\_2 register) when the WD\_RST\_EN bit (bit 3 in SAFETY\_FUNC\_CFG) is set to 1. Also set to 1 when the DIAGNOSTIC state time-out occurs.
- Cleared by using the SPI to write a 0 to the bit when the watchdog fail counter is less than 7 or cleared to 0 during a reset event. **Note:** in the DIAGNOSTIC state, writing this bit to 1 is also possible, leaving it set at 1 when exiting the DIAGNOSTIC state causes a transition to the SAFE state.

**D[3:0] DEV\_ERR\_CNT[3:0]**

- Tracks the current device error count.
- Overwritten by SPI WR access, but ONLY in the DIAGNOSTIC mode.

### 5.5.4.13 SAFETY\_ERR\_PWM\_H Register

**Initialization source:** NPOR

**Controller access:** Read (RD\_SAFETY\_ERR\_PWM\_H)

Write (WR\_SAFETY\_ERR\_PWM\_H). Write update can only occur in the DIAGNOSTIC state. Write access locked through SW\_LOCK command.

**Figure 5-35. SAFETY\_ERR\_PWM\_H Register**

D7	D6	D5	D4	D3	D2	D1	D0
PWMH[7]	PWMH[6]	PWMH[5]	PWMH[4]	PWMH[3]	PWMH[2]	PWMH[1]	PWMH[0]
1b	0b	1b	0b	1b	0b	0b	0b

**D[7:0] PWMH[7:0]:** The ERROR/WDI pin high-phase duration in PWM mode (15- $\mu$ s resolution)

- Controls the expected high-phase duration with 15- $\mu$ s resolution
- Use [Equation 17](#) and [Equation 18](#) to calculate the minimum and maximum values for the HIGH pulse duration,  $t_{PWM\_HIGH}$ . (15- $\mu$ s time reference has 5% accuracy coming from 4-MHz internal oscillator)

#### 5.5.4.14 SAFETY\_ERR\_PWM\_L Register

**Initialization source:** NPOR

**Controller access:** Read (RD\_SAFETY\_ERR\_PWM\_L)

Write (WR\_SAFETY\_ERR\_PWM\_L). Write update can only occur in the DIAGNOSTIC state. Write access locked through SW\_LOCK command.

**Figure 5-36. SAFETY\_ERR\_PWM\_L Register**

D7	D6	D5	D4	D3	D2	D1	D0
PWML[7]	PWML[6]	PWML[5]	PWML[4]	PWML[3]	PWML[2]	PWML[1]	PWML[0]
0b	0b	1b	1b	1b	1b	0b	1b

**D[7:0] PWML[7:0]:** The ERROR/WDI pin low-phase duration

- Controls expected low-phase duration
  - When the ERR\_CFG bit is 0 (in PWM mode): PWM low-phase duration with 15- $\mu$ s resolution  
Use Equation 19 and Equation 20 to calculate the minimum and maximum values for the LOW pulse duration,  $t_{\text{PWM\_LOW}}$ . (15- $\mu$ s time reference has 5% accuracy coming from 4-MHz internal oscillator)
  - When ERR\_CFG bit is 1 (TMS570 mode): error low duration with 5- $\mu$ s resolution  
Use Equation 15 and Equation 16 to calculate the minimum and maximum values for the LOW duration,  $t_{\text{TMS570\_LOW}}$ . (5- $\mu$ s time reference has 5% accuracy coming from 4-MHz internal oscillator)

#### 5.5.4.15 SAFETY\_PWD\_THR\_CFG Register

**Initialization source:** NPOR

**Controller access:** Read (RD\_SAFETY\_PWD\_THR\_CFG)

Write (WR\_SAFETY\_PWD\_THR\_CFG). Write update can only occur in the DIAGNOSTIC state. Write access locked through SW\_LOCK command.

**Figure 5-37. SAFETY\_PWD\_THR\_CFG Register**

D7	D6	D5	D4	D3	D2	D1	D0
RSV	RSV	RSV	RSV	PWD_THR[3]	PWD_THR[2]	PWD_THR[1]	PWD_THR[0]
0b	0b	0b	0b	1b	1b	1b	1b

**D[7:4] RSV**

**D[3:0] PWD\_THR[3:0]:** Device error-count threshold to power down the device

- When the DEV\_ERR\_CNT[3:0] counter reaches the programmed threshold, the device powers down.
- The device recovers with a new wake-up or ignition event.

#### 5.5.4.16 SAFETY\_CFG\_CRC Register

**Initialization source:** NPOR

**Controller access:** Read (RD\_SAFETY\_CFG\_CRC)

Write (WR\_SAFETY\_CFG\_CRC). Write update can only occur in the DIAGNOSTIC state. Write access locked through SW\_LOCK command.

**Figure 5-38. SAFETY\_CFG\_CRC Register**

D7	D6	D5	D4	D3	D2	D1	D0
CFG_CRC[7]	CFG_CRC[6]	CFG_CRC[5]	CFG_CRC[4]	CFG_CRC[3]	CFG_CRC[2]	CFG_CRC[1]	CFG_CRC[0]
0b	0b	0b	1b	0b	0b	0b	0b

**D[7:0] CFG\_CRC[7:0]:** The CRC8 value for the safety configuration registers

### 5.5.4.17 Diagnostics

#### 5.5.4.17.1 DIAG\_CFG\_CTRL Register

**Initialization source:** NPOR, post LBIST reinitialization

**Controller access:** Read (RD\_DIAG\_CFG\_CTRL)

Write (WR\_DIAG\_CFG\_CTRL)

**Figure 5-39. DIAG\_CFG\_CTRL Register**

D7	D6	D5	D4	D3	D2	D1	D0
MUX_EN	SPI_SDO	MUX_OUT	INT_CON[2]	INT_CON[1]	INT_CON[0]	MUX_CFG[1]	MUX_CFG[0]
0b	0b	0b	0b	0b	0b	0b	0b

- D[7] MUX\_EN:** Enable diagnostic MUX output  
0b = Disabled (tri-stated)  
1b = Enabled
- D[6] SPI\_SDO:** To control the SPI\_SDO output-buffer state during an interconnect test  
To check the SDO diagnostics use the following sequence:
  - MUX\_CFG[1:0] configuration must be 01b (Digital MUX Mode)
  - SPI NCS must be kept HIGH
  - The state of the SDO pin is controlled by the SPI\_SDO bit
- D[5] MUX\_OUT:** Diagnostic MUX output-state control bit  
**Note:** When the MUX\_CFG bits are set to 00b and the MUX\_EN bit is set to 1
- D[4:2] INT\_CON[2:0]:** Device interconnect-test configuration bits  
000b = No active interconnect test  
001b = ERR input state observed on the diagnostic MUX output  
010b = SPI\_NCS input state observed on the diagnostic MUX output  
011b = SPI\_SDI input state observed on the diagnostic MUX output  
100b = SPI\_SCLK input observed on the diagnostic MUX output  
101b = Not applicable  
110b = Not applicable  
111b = Not applicable
- D[1:0] MUX\_CFG[1:0]:** Diagnostic MUX configuration  
00b = The MUX output is controlled by MUX\_OUT bit (bit 5 in DIAG\_CFG\_CTRL register)  
01b = Digital MUX mode  
10b = Analog MUX mode  
11b = Device interconnect mode (input-pins interconnect test)

#### 5.5.4.17.2 DIAG\_MUX\_SEL Register

**Initialization source:** NPOR, post LBIST reinitialization

**Controller access:** Read (RD\_DIAG\_MUX\_SEL )

Write (WR\_DIAG\_MUX\_SEL)

**Figure 5-40. DIAG\_MUX\_SEL Register**

D7	D6	D5	D4	D3	D2	D1	D0
MUX_SEL[7]	MUX_SEL[6]	MUX_SEL[5]	MUX_SEL[4]	MUX_SEL[3]	MUX_SEL[2]	MUX_SEL[1]	MUX_SEL[0]
0b	0b	0b	0b	0b	0b	0b	0b

- D[7:0] MUX\_SEL[7:0]:** Diagnostic MUX channel select  
**Note:** The MUX channel table is dependent on the MUX\_CFG[1:0] bit settings in the DIAG\_CFG\_CTRL register (see [Section 5.5.4.17.1](#))

## 5.5.5 Watchdog Timer

### 5.5.5.1 WD\_TOKEN\_FDBK Register

**Initialization source:** NPOR

**Controller access:** Read (RD\_WD\_TOKEN\_FDBK)

Write (WR\_WD\_TOKEN\_FDBK). Write update can only occur in the DIAGNOSTIC state. Write access locked through SW\_LOCK command.

**Figure 5-41. WD\_TOKEN\_FDBK Register**

D7	D6	D5	D4	D3	D2	D1	D0
FDBK[3]	FDBK[2]	FDBK[1]	FDBK[0]	TOKEN_SEED[3]	TOKEN_SEED[2]	TOKEN_SEED[1]	TOKEN_SEED[0]
0b	0b	0b	0b	0b	0b	0b	0b

**D[7:4] FDBK[3:0]:** Watchdog question (token) FSM feedback configuration bits

- FDBK [3:0] bits control the sequence of generated questions and Markov chain polynomial
- The device has a set of 16 generated questions, repetition or sequence ordering can be adjusted by the FDBK[3:0] bits
- FDBK[3:2] controls the question (TOKEN) generation for the watchdog in Q&A mode
- FDBK[2:1] controls the LFSR configuration for the watchdog question (TOKEN) generation
- FDBK[0] RSV

**D[3:0] TOKEN\_SEED[3:0]:** Watchdog token seed value, used to generate a set of new questions (tokens)

- The token seed value can be updated by the MCU only after watchdog is reinitialization in the DIAGNOSTIC state after RESET. The new TOKEN\_SEED[3:0] value takes effect after another transition through the RESET state with AUTO\_BIST\_DIS = 1:
- Only for Q&A Mode

### 5.5.5.2 WD\_WIN1\_CFG Register

**Initialization source:** NPOR

**Controller access:** Read (RD\_WD\_WIN1\_CFG)

Write (WR\_WD\_WIN1\_CFG). Write update can only occur in the DIAGNOSTIC state. Write access locked through SW\_LOCK command.

**Figure 5-42. WD\_WIN1\_CFG Register**

D7	D6	D5	D4	D3	D2	D1	D0
RSV	RT[6]	RT[5]	RT[4]	RT[3]	RT[2]	RT[1]	RT[0]
0b	1b	1b	1b	1b	1b	1b	1b

D[7] RSV

**D[6:0] RT[6:0]:** Watchdog Window 1 duration setting

- See [Equation 1](#) and [Equation 2](#) to calculate the minimum and maximum values for the  $t_{WIN1}$  time period.

### 5.5.5.3 WD\_WIN2\_CFG Register

**Initialization source:** NPOR

**Controller access:** Read (RD\_WD\_WIN2\_CFG)

Write (WR\_WD\_WIN2\_CFG). Write update can only occur in the DIAGNOSTIC state. Write access locked through SW\_LOCK command.

**Figure 5-43. WD\_WIN2\_CFG Register**

D7	D6	D5	D4	D3	D2	D1	D0
RSV	RSV	RSV	RW[4]	RW[3]	RW[2]	RW[1]	RW[0]
0b	0b	0b	1b	1b	0b	0b	0b

D[7:5] RSV

**D[4:0] RW[4:0]:** Watchdog Window 2 duration setting

- See [Equation 3](#) and [Equation 4](#) to calculate the minimum and maximum values for the  $t_{WIN2}$  time period.

### 5.5.5.4 WD\_TOKEN\_VALUE Register

**Initialization source:** NPOR, post LBIST reinitialization  
**Controller access:** Read only (RD\_WD\_TOKEN\_VALUE)

Figure 5-44. WD\_TOKEN\_VALUE Register

D7	D6	D5	D4	D3	D2	D1	D0
WD_FAIL_TH	RSV	RSV	RSV	TOKEN[3]	TOKEN[2]	TOKEN[1]	TOKEN[0]
1b	0b	0b	0b	0b	0b	0b	0b

- D[7] WD\_FAIL\_TH**
  - Set to 1 when the watchdog fail counter reaches a count of 5 or higher (WD\_FAIL\_CNT[2:0] bits in the SAFETY\_STAT\_2 register)
  - Cleared to 0 when the watchdog fail counter reaches a count of less than 5 (WD\_FAIL\_CNT[2:0] bits in the SAFETY\_STAT\_2 register)
- D[6:4] RSV**
- D[3:0] TOKEN[3:0]:** watchdog question (token)
  - The MCU must read (or calculate) the current question (token) to generate a correct answer bytes.
  - Only for Q&A mode

### 5.5.5.5 WD\_STATUS Register

**Initialization source:** NPOR, post LBIST reinitialization  
**Controller access:** Read only (RD\_WD\_STATUS)

Figure 5-45. WD\_STATUS Register

D7	D6	D5	D4	D3	D2	D1	D0
WD_ANSW_CNT [1]	WD_ANSW_CNT [0]	ANSWER_ERR	WD_WRONG_CFG	WD_CFG_CHG	SEQ_ERR	TIME_OUT	ANSWER_EARLY
1b	1b	0b	0b	0b	0b	0b	0b

- D[7:6] WD\_ANSW\_CNT[1:0]:** Current watchdog answer count
  - Only for Q&A mode
- D[5] ANSWER\_ERR:** Watchdog error-status bit to show the incorrect Answer-x byte (formerly TOKEN\_ERR)
  - This bit is set to 1 as soon as an Answer-x byte (WD\_TOKEN\_RESPx) is not correct. This flag is cleared if the following answer is correct again or at the beginning of a new watchdog sequence. This bit is not cleared on SPI read-out.
  - Only for Q&A mode
- D[4] WD\_WRONG\_CFG**
  - Set to 1 when either the WD\_WIN1\_CFG or WD\_WIN2\_CFG bits are set to 00h.
- D[3] WD\_CFG\_CHG:** Watchdog configuration-change status bit
  - This bit is set to 1 when WD\_WIN1\_CFG or WD\_WIN2\_CFG setting is changed. This bit is cleared at the beginning of a new watchdog sequence.
- D[2] SEQ\_ERR:** Any of the answer bytes are wrong
  - Incorrect timing or wrong answer
  - Only for Q&A mode
- D[1] TIME\_OUT:** No watchdog event (trigger or four answer-x bytes) received within the watchdog sequence (time-out event)
  - In trigger mode (default): set to 1 when no trigger has been received on the ERROR/WDI pin during the watchdog sequence
  - In Q&A mode: set to 1 when less than four Answer-x bytes have been received during the watchdog sequence
  - This flag can be used to resynchronize the MCU timing to the device watchdog.
  - Cleared to 0 by SPI read access, cleared to 0 after a watchdog *good event* or *bad event*, or cleared to 0 during reset event.  
**Note:** In the DIAGNOSTIC state, writing this bit to 1 is possible, leaving it set at 1 has the same device level impact as a detected failure on the ERROR/WDI pin.
- D[0] ANSWER\_EARLY:** Answer-x bytes completed too early or trigger too early (formerly TOKEN\_EARLY)
  - Set to 1 if the four answer bytes are returned during Window 1 or the trigger occurs in Window 1

### 5.5.5.6 WD\_ANSWER Register

**Initialization source:** NPOR

**Controller access:** Write only (WR\_WD\_ANSWER)

**Figure 5-46. WD\_ANSWER Register**

D7	D6	D5	D4	D3	D2	D1	D0
WD_ANSW[7]	WD_ANSW[6]	WD_ANSW[5]	WD_ANSW[4]	WD_ANSW[3]	WD_ANSW[2]	WD_ANSW[1]	WD_ANSW[0]
0b	0b	0b	0b	0b	0b	0b	0b

**D[7:0]** **WD\_ANSW[7:0]:** answer bytes

- See [Section 5.4.15.4](#) for details on answer bytes
- Only for Q&A mode

## 5.5.6 Sensor Supply

### 5.5.6.1 SENS\_CTRL Register

**Initialization source:** NPOR

**Controller access:** Read (RD\_SENS\_CTRL)

Write (WR\_SENS\_CTRL)

**Figure 5-47. SENS\_CTRL Register**

D7	D6	D5	D4	D3	D2	D1	D0
RSV	RSV	RSV	VDD5_EN	RSV	RSV	RSV	VSOUT1_EN
0b	0b	0b	1b	0b	0b	0b	0b

**D[7:5]** RSV

**D[4]** **VDD5\_EN:** If cleared to 0, the VDD5 regulator turns off.

- This bit is set to 1 by default, and is cleared in case of the VDD5 over temperature condition (indicated by the VDD5\_OT bit D1 in the SAFETY\_STAT1 register).

**Note:** When the VDD5 regulator is disabled, the VDD5\_ILIM bit (bit D7 in the SAFETY\_STAT\_1 register) is set to 1 and remains set to 1 as long as the VDD5 regulator is disabled (or the VDD5\_EN bit is 0). However, the VDD5\_OV and VDD5\_UV bits reflect an overvoltage or undervoltage condition on the VDD5 regulator.

**D[3:1]** RSV

**D[0]** **VSOUT1\_EN:** Sensor-supply enable bit (set this bit to 1 to enable the VSOUT1 sensor supply)

- This bit is cleared to 0 by default, and must be set to 1 by the MCU to enable the VSOUT1 sensor supply. In case of a VSOUT1 overtemperature condition (indicated by the VSOUT1\_OT bit D2 in the SAFETY\_STAT1 regulator), the VSOUT1 regulator is disabled and this bit, VSOUT1\_EN, is cleared to 0. When the overtemperature condition in the VSOUT1 sensor supply is no longer present, the VSOUT1 sensor supply must be reenabled.

## 6 Application and Implementation

---

### NOTE

Information in the following applications sections is not part of the TI component specification, and TI does not warrant its accuracy or completeness. TI's customers are responsible for determining suitability of components for their purposes. Customers should validate and test their design implementation to confirm system functionality.

---

### 6.1 Application Information

The TPS65381-Q1 device is a multirail power supply including one buck preregulator, one linear controller, one 5-V linear regulator, one programmable 3.3-V or 5-V linear regulator, and one linear tracking regulator with protection against short to battery and ground. The device has many diagnostic and monitoring functions. This device provides a power-management basis for many different applications.

### 6.2 Typical Application

The following design requirements and design procedure are an example of how to select component values for the TPS65381-Q1 device for a typical application. Because many of the regulators are adjustable, the equations should be used to calculate the component values for the specific application. For additional reference, also refer to the design checklist and application notes listed in [Section 9.2.1](#).

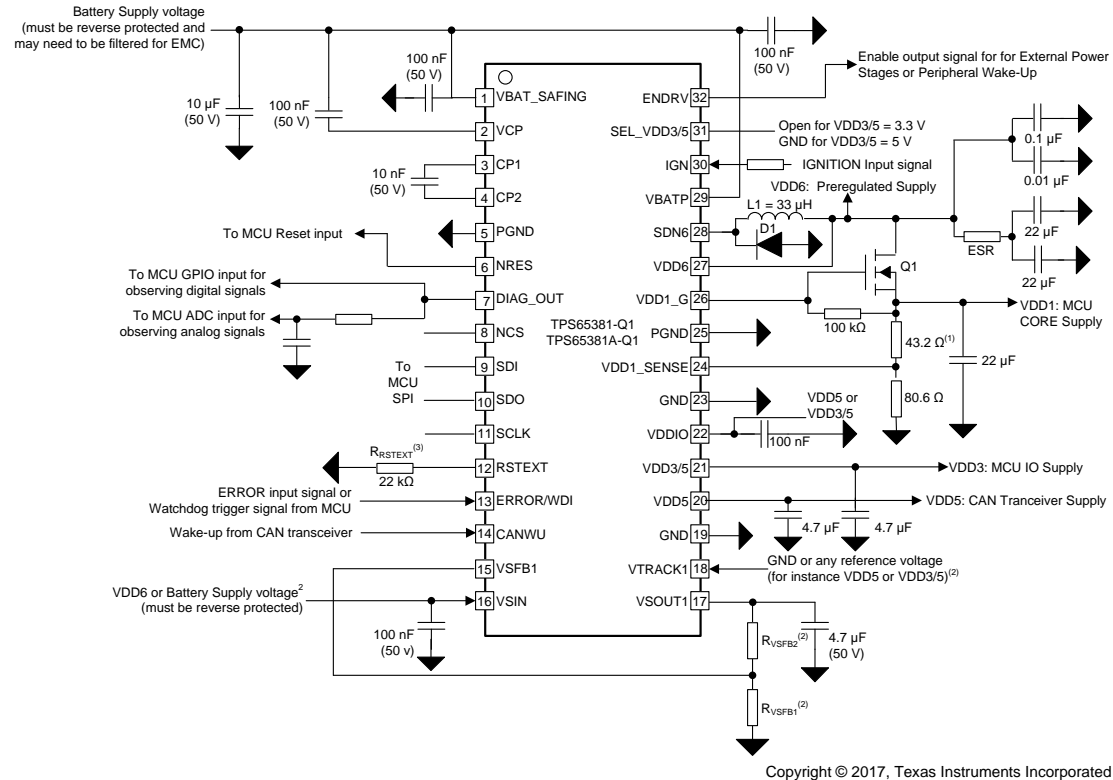

Copyright © 2017, Texas Instruments Incorporated

Example components:

- Q1: BUK9213-30A
- D1: Vishay SS3H09/10, OnSemi MBRS340T3
- D2: ROHM UDZSTE-176.2B
- L1: TDK CLF10060NIT-330M-D or COILCRAFT MSS1246T-333ML

NOTE:

1. 43.2 Ω for 1.23-V output voltage (Recommended for TI TMS570 MCU). Change this resistor to obtain different VDD1 output voltage,  $VDD1\_SENSE = 800\text{ mV}$ . The tolerance of the resistors in this resistor divider will impact VDD1 regulation and voltage monitoring tolerance. Resistors with 0.1% tolerance are recommended.
2.  $R_{VSFB1}$  and  $R_{VSFB2}$  configure the VSOUT1 voltage
  - Pin 16 (VSIN) to be connected either to pin 27 (VDD6) for  $VSOUT1 \leq 5\text{ V}$  or to pin 29 (VBATP) for  $5\text{ V} < VSOUT1 < 9.5\text{ V}$
  - Pin 18 (VTRACK1) to be connected to GND for non-tracking mode, or a reference voltage (for example VDD5 or VDD3/5) for tracking mode.
  - The tolerance of the resistors in this resistor divider will impact VSOUT1 regulation and voltage monitoring tolerance. Resistors with 0.1% tolerance are recommended.
  - See Section 5.3.5 for details.
3.  $R_{RSEXT}$  configures the Reset Extension time. See the *Reset and Enable outputs* section of Section 4.5

Figure 6-1. Typical Application Diagram

## 6.2.1 Design Requirements

While selecting capacitors for the application consider the following characteristics:

- The effective capacitance at the operating voltage must be used when selecting the proper capacitor. Capacitors derate with operating voltage, sometimes as much as 70%. Therefore the capacitance of the circuit could be outside of the specified value for the capacitor as listed in [Section 4](#).
- The temperature and lifetime of the capacitor can also impact the effective capacitance and should be considered.
- The voltage ratings of the capacitor should be considered, especially on the high-voltage input circuits that can also experience transient voltages.

These impacts must all be considered when selecting a capacitor so that the circuit has the specified capacitance required for this device at the application operating conditions of the capacitor such as temperature, voltage, and lifetime.

The VBATP and VBAT\_SAFING pins are the supply inputs to the device. These supplies must be reverse-battery protected. The supplies should also be adequately protected against transients and have sufficient noise filtering for the intended application. If the application has noisy and high-current output drives that are connected to either the VBATP pin, VBAT\_SAFING pin, or both, additional filtering may be necessary between the output drive and the device.

The IGN pin is a wake-up input to the device. This input provides up to –7 V of protection. Beyond this voltage, the IGN pin must be reverse protected. If the noise can occur longer than the specified deglitch time, the IGN pin should also be adequately protected against transients and have sufficient noise filtering for the intended application.

## 6.2.2 Detailed Design Procedure

### 6.2.2.1 VDD6 Preregulator

The inductor, output capacitor, and total effective series resistance (ESR) of the output capacitance must be considered to achieve balanced operation of the VDD6 preregulator.

The output inductor must be greater than or equal to the minimum 22- $\mu$ H inductance. The typical specified inductance is 33  $\mu$ H, which was selected for this design.

The effective output capacitance for the VDD6 preregulator is specified from 22  $\mu$ F to 47  $\mu$ F. An effective capacitance of 22  $\mu$ F at the 6-V DC operating point was selected for this design. This value allows for additional downstream input capacitance on voltage regulator inputs. To filter high frequencies, use 10-nF and 0.1- $\mu$ F capacitors in parallel. If higher effective capacitance is used, the voltage ripple is reduced and lowers the required ESR. The effective capacitance of a capacitor should be provided by the capacitor supplier and must be derated for tolerance, lifetime, temperature, and operating voltage.

Because the VDD6 preregulator is a hysteretic architecture, controlled ESR is required with the output capacitance. The specified ESR range is from 100 m $\Omega$  to 300 m $\Omega$ . Use [Equation 21](#) to calculate the minimum total ESR to achieve balanced operation.

$$R_{ESR} = L / (15 \times C_{Effective}) = 33 / (15 \times 22) = 100 \text{ m}\Omega \quad (21)$$

As an example, the data sheet for the capacitor states that the ESR of the capacitor is 4 m $\Omega$  and the parasitic extraction of the PCB design is 6 m $\Omega$ . An ESR resistor of 100 m $\Omega$  can still be used, or the discrete ESR resistor can be sized to 90 m $\Omega$  resulting in a total effective ESR of at least 100 m $\Omega$ . If a larger effective capacitance is used, the equation may result in an ESR value below 100 m $\Omega$ . In this case, the total ESR should still be brought up to 100-m $\Omega$  total ESR minimum to meet the specification.

A high-voltage surface-mount Schottky-rectifier diode, such as SS3H9/10 or MBRS340T3, should be used.

[Figure 6-2](#) shows this configuration.

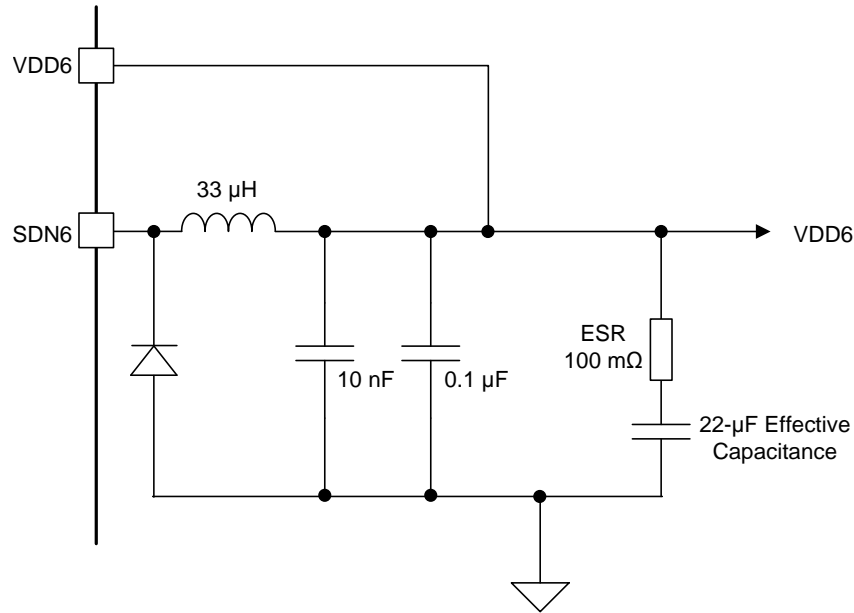

Figure 6-2. VDD6 Design

### 6.2.2.2 VDD1 Linear Controller

The microprocessor used with the TPS65381-Q1 device requires a core voltage of 1.23 V.

The output voltage of the VDD1 linear controller is set by a resistor divider from the VDD1 output to ground with the divided voltage connected to the VDD1\_SENSE pin, which must be set to 800 mV. To ensure sufficient bias current through the resistor divider, select a value of R1 as 80.6 Ω. Use Equation 22 to calculate the resistance of R2.

$$R2 = ([VDD1 \times R1] / V_{VDD1\_SENSE}) - R1 = ([1.23 \text{ V} \times 80.6 \Omega] / 0.8 \text{ V}) - 80.6 \Omega = 43.3 \Omega \quad (22)$$

Select the standard value of 43.2 Ω.

#### NOTE

The tolerance of the R1 and R2 resistors in this resistor divider will impact the VDD1 regulation and voltage monitoring tolerance. Resistors with 0.1% tolerance are recommended.

Select an output FET for the VDD1 linear controller that meets the requirements in the *VDD1 – LDO With External FET* specifications in Section 4.5. An example output FET is BUK9213-30A. The gate of the output FET is connected to the VDD1\_G pin. A 100-kΩ resistor is connected between the gate and source of the FET. The drain of the FET is connected to the VDD6 preregulator output, which is used as the supply input for the VDD1 linear controller.

A low-ESR ceramic output capacitor with 22-µF effective capacitance at 1.23 V is used to meet the requirements for the output capacitor that is listed in this data sheet. Depending on the application, this output may require a larger output capacitor to ensure the output does not drop below the required regulation specification during load transients. The VDD1 output capacitance is specified up to 40 µF.

Figure 6-3 shows this configuration.

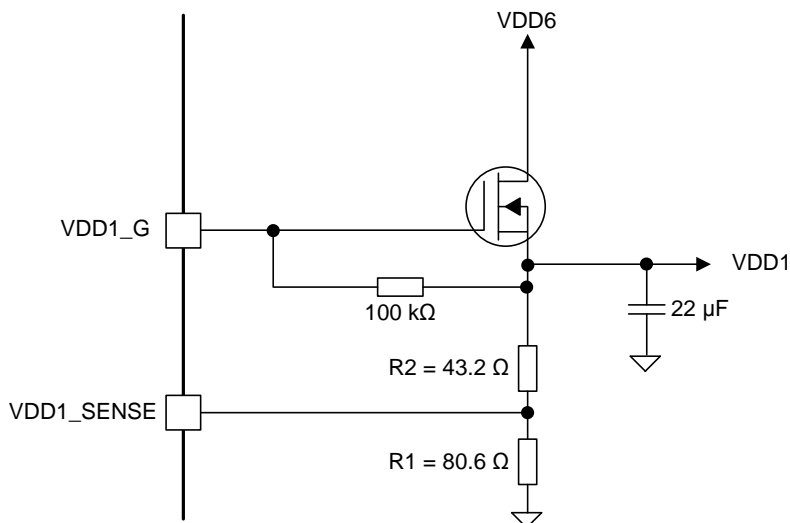

Figure 6-3. VDD1 Design

### 6.2.2.3 VSOUT1 Tracking Linear Regulator, Configured to Track VDD5

The system has a sensor that requires a 5-V supply that must track the VDD5 supply. The configuration should be set up for higher efficiency.

The VDD5 output is connected to the VTRACK1 pin, which configures the regulator for tracking mode. Because the output must track the input, unity gain feedback is used on the VSFB1 pin by connecting it to the VSOUT1 pin.

For efficiency, use the VDD6 preregulator as the supply. Therefore, the VDD6 output is connected to VSIN. A local, low-ESR 100-nF ceramic capacitor is used on the VSIN pin to stabilize the input.

A local, low-ESR 4.7-μF ceramic capacitor is used on the VSOUT1 output for loop stabilization. Depending on the application, this output may require a larger output capacitor to ensure that the output does not drop below the required regulation specification during load transients. The VSOUT1 output capacitance is specified up to 10 μF.

Figure 6-4 shows this configuration.

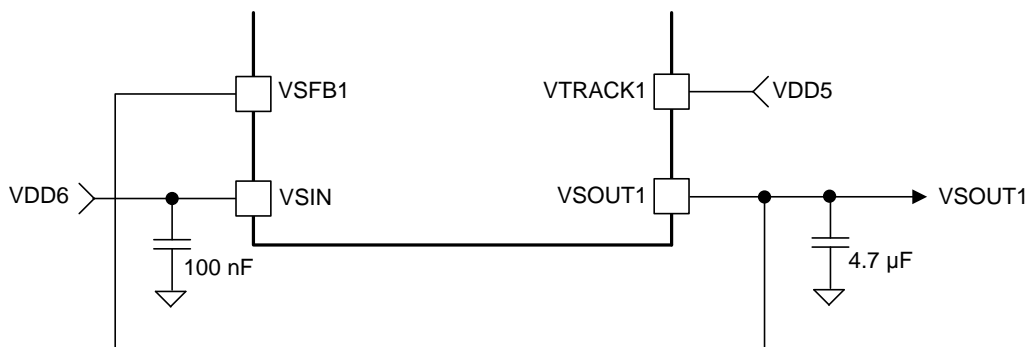

Figure 6-4. VSOUT1 Design—Tracking, No Gain

### 6.2.2.4 Alternative Use for VSOUT1 Tracking Linear Regulator, Configured for 6-V Output Tracking VDD3/5 In 3.3-V Mode

The system has a sensor that requires a 6-V supply that must track the VDD3/5 supply operating at 3.3 V.

The VDD3/5 supply, operating in 3.3-V mode, is connected to the VTRACK1 pin, which configures the regulator for tracking mode. Because the output must have gain to make the 6-V output track a 3.3-V supply, gain feedback is used on the VSFB1 pin. To achieve the required gain, connect a resistor divider the VSOUT1 and VSFB1 pins. Select a value of 3.3 kΩ for the R<sub>VSFB1</sub> resistor to balance the current through the resistor divider for reasonable bias current and reasonable losses. Use Equation 23 to calculate the resistance of R<sub>VSFB2</sub>.

$$R_{VSFB2} = ([VSOUT1 \times R_{VSFB1}] / VTRACK) - R_{VSFB1} = ([6 \text{ V} \times 3.3 \text{ k}\Omega] / 3.3 \text{ V}) - 3.3 \text{ k}\Omega = 2.7 \text{ k}\Omega \quad (23)$$

Select the standard value of 2.7 kΩ.

#### NOTE

The tolerance of the R<sub>VSFB1</sub> and R<sub>VSFB2</sub> resistors in this resistor divider will impact the VSOUT1 regulation and voltage monitoring tolerance. Resistors with 0.1% tolerance are recommended.

Because the desired VSOUT1 output is greater than 5 V, the VBATP supply must be used for the tracking supply. Therefore, connect the VBATP supply to the VSIN pin. A local, low-ESR 100-nF ceramic capacitor is used on the VSIN pin to stabilize the input.

A local, low-ESR 4.7-μF ceramic capacitor is used on the VSOUT1 pin for loop stabilization. Depending on the application, this output may require a larger output capacitor to ensure that the output does not drop below the required regulation specification during load transients. The VSOUT1 output capacitance is specified up to 10 μF.

Figure 6-5 shows this configuration.

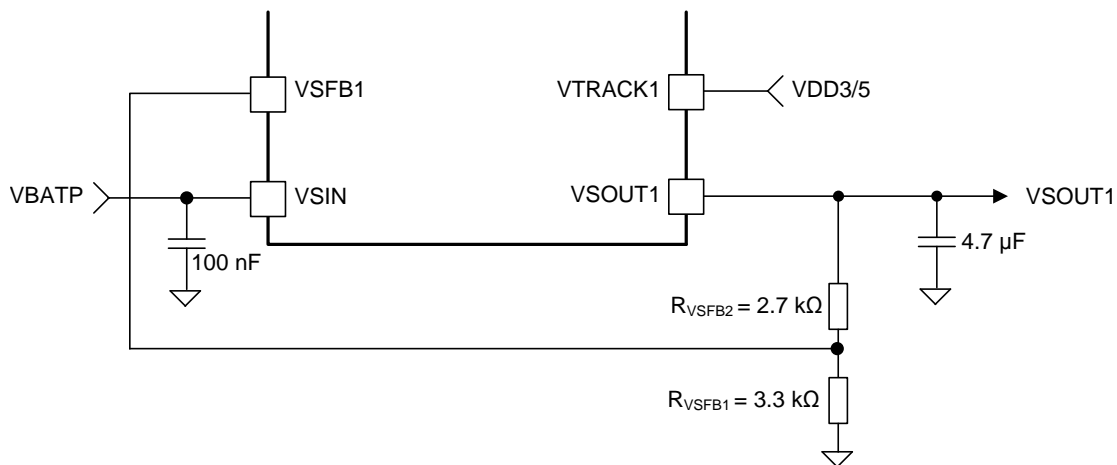

Figure 6-5. VSOUT1 Design—Tracking, With Gain (VDD3/5)

### 6.2.2.5 Alternative Use for VSOUT1 Tracking Linear Regulator, Configured for 9-V Output Tracking to 5-V Input from VDD5

The system has a sensor that requires a 9-V supply that must track the VDD5 supply operating at 5 V.

The VDD5 supply is connected to VTRACK1, which configures the regulator for tracking mode. Because the output must have gain to make the 9-V output track a 5-V supply, gain feedback is used on the VSFB1 pin. To achieve the required gain, connect a resistor divider between the VSOUT1 and VSFB1 pins. Select a value of 3.3 k $\Omega$  for the R<sub>VSFB1</sub> resistor to balance the current through the resistor divider for reasonable bias current and reasonable losses. Use Equation 24 to calculate the resistance of R<sub>VSFB2</sub>.

$$R_{VSFB2} = ([VSOUT1 \times R_{VSFB1}] / VTRACK) - R_{VSFB1} = ([9 \text{ V} \times 3.3 \text{ k}\Omega] / 5 \text{ V}) - 3.3 \text{ k}\Omega = 2.64 \text{ k}\Omega \quad (24)$$

Select the standard value of 2.7 k $\Omega$ .

#### NOTE

The tolerance of the R<sub>VSFB1</sub> and R<sub>VSFB2</sub> resistors in this resistor divider will impact the VSOUT1 regulation and voltage monitoring tolerance. Resistors with 0.1% tolerance are recommended.

Because the desired VSOUT1 output is greater than 5-V, the VBATP supply must be used as the tracking supply. Therefore, connect the VBATP supply to the VSIN pin. A local, low-ESR 100-nF ceramic capacitor is used on the VSIN pin to stabilize the input.

A local, low-ESR 4.7- $\mu$ F ceramic capacitor is used on the VSOUT1 pin for loop stabilization. Depending on the application, this output may require a larger output capacitor to ensure that the output does not drop below the required regulation specification during load transients. The VSOUT1 output capacitance is specified up to 10  $\mu$ F.

Figure 6-6 shows this configuration.

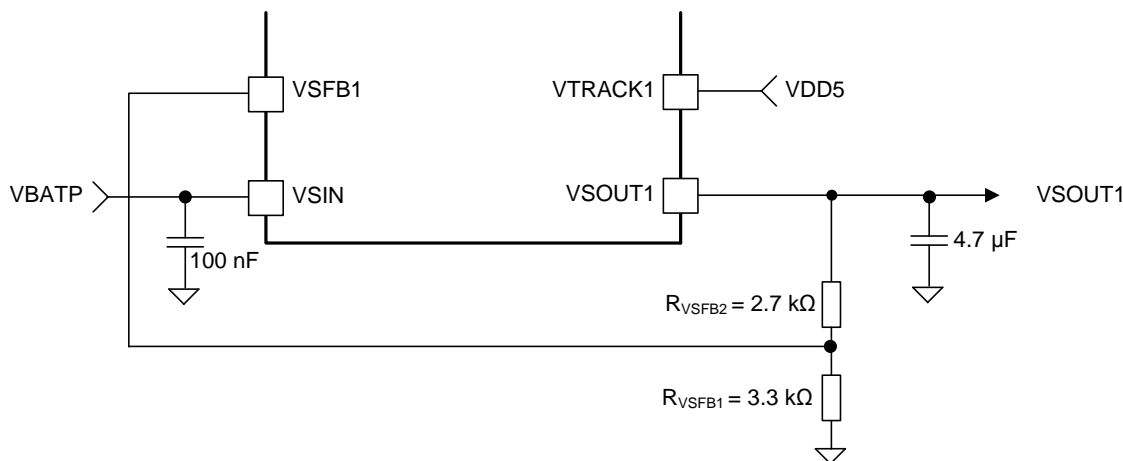

**Figure 6-6. VSOUT1 Design—Tracking, With Gain (VDD5)**

### 6.2.2.6 Alternative Use for VSOUT1 Tracking Linear Regulator, Configured in Non-tracking Mode Providing a 4.5-V Output

If the system requires a 4.5-V supply that does not track any other supply, the VTRACK1 pin is connected to ground (GND), which configures the regulator for non-tracking mode. The output is now proportional to a fixed reference voltage ( $V_{ref}$ ) of 2.5 V on the VSFB1 pin. Because the output must have gain to result in a 4.5-V output, gain feedback will be used on the VSFB1 pin. To achieve the required gain, connect a resistor divider between the VSOUT1 and VSFB1 pins. Select a value of 3.3 k $\Omega$  for the R<sub>VSFB1</sub> resistor to balance the current through the resistor divider for reasonable bias current and reasonable losses. Use [Equation 25](#) to calculate the resistance of R<sub>VSFB2</sub>.

$$R_{VSFB2} = ((VSOUT1 \times R_{VSFB1}) / V_{ref}) - R_{VSFB1} = ((4.5 \text{ V} \times 3.3 \text{ k}\Omega) / 2.5 \text{ V}) - 3.3 \text{ k}\Omega = 2.64 \text{ k}\Omega \quad (25)$$

Select the standard value of 2.7 k $\Omega$ .

#### NOTE

The tolerance of the R<sub>VSFB1</sub> and R<sub>VSFB2</sub> resistors in this resistor divider will impact the VSOUT1 regulation and voltage monitoring tolerance. Resistors with 0.1% tolerance are recommended.

For efficiency, the VDD6 preregulator is the supply and therefore the VDD6 output is connected to the VSIN pin. A local, low-ESR 100-nF ceramic capacitor is used on the VSIN pin to stabilize the input.

A local, low-ESR 4.7- $\mu$ F ceramic capacitor is used on the VSOUT1 pin for loop stabilization. Depending on the application, this output may require a larger output capacitor to ensure that the output does not drop below the required regulation specification during load transients. The VSOUT1 output capacitance is specified up to 10  $\mu$ F.

Figure 6-7 shows this configuration.

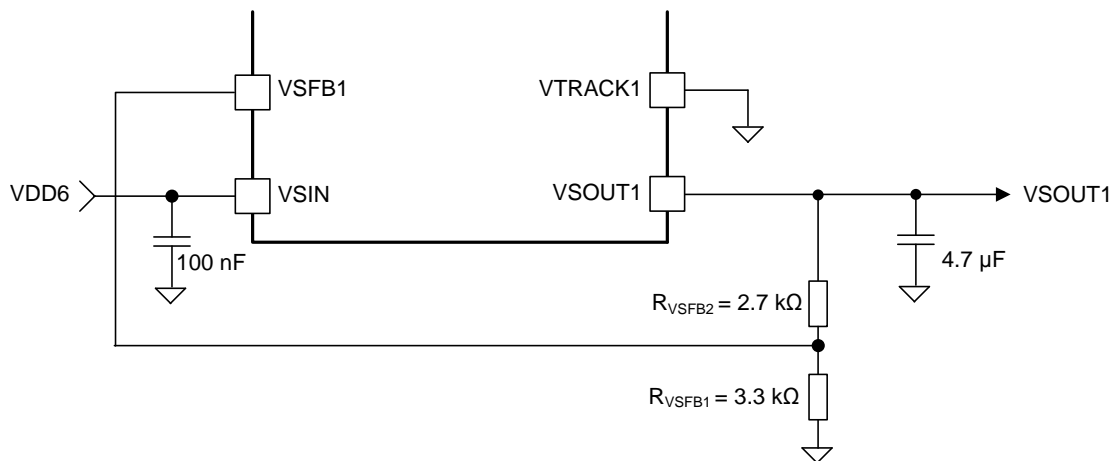

Figure 6-7. VSOUT1 Design—Non-Tracking

### 6.2.3 Application Curves

For the application curves, see the figures listed in [Table 6-1](#).

Table 6-1. Table of Graphs

FIGURE TITLE	FIGURE NUMBER
SPI SDO Buffer Source and Sink Current	<a href="#">Figure 4-3</a>
VDD6 BUCK Efficiency	<a href="#">Figure 4-4</a>

### 6.3 System Examples

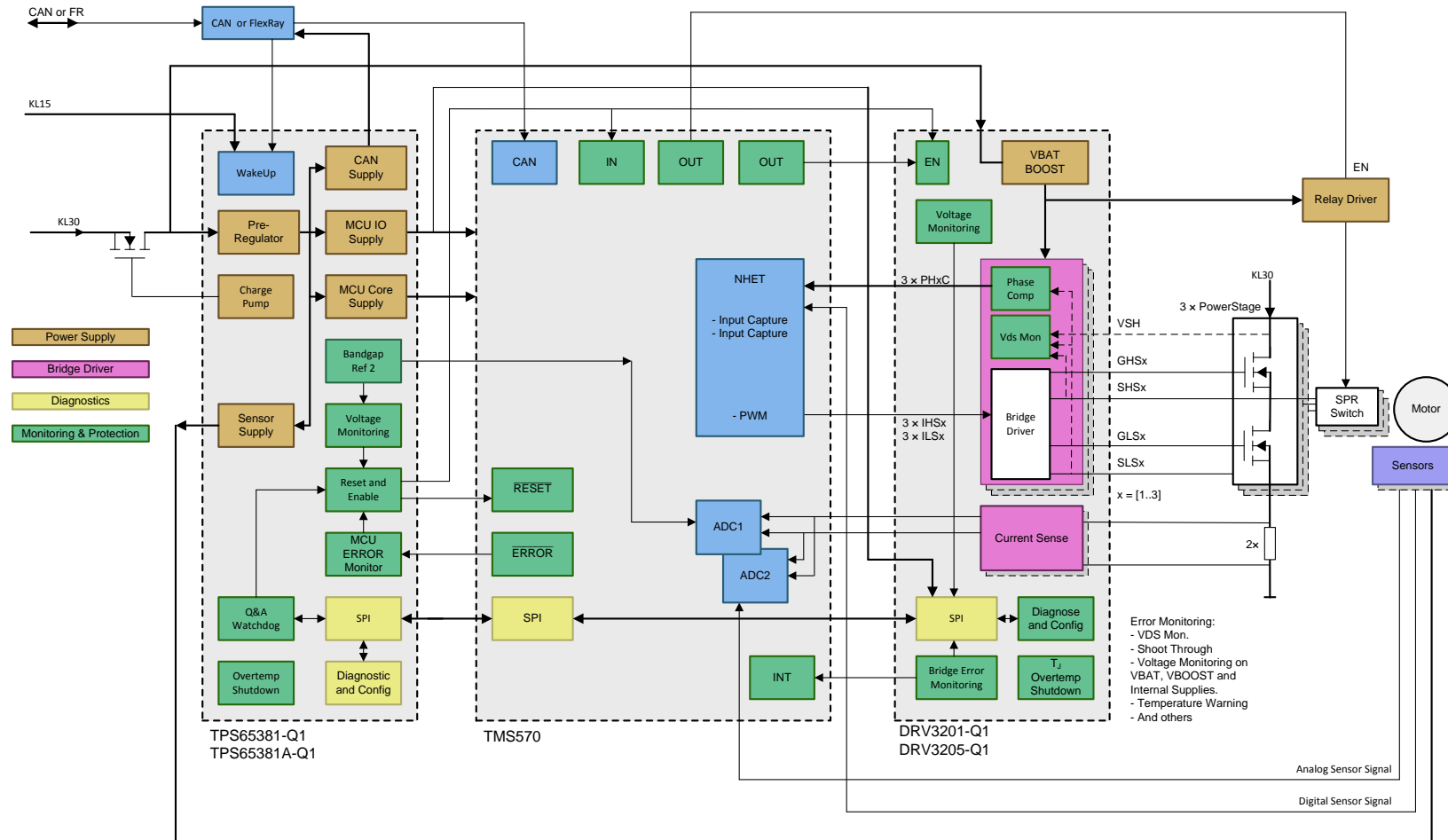

Copyright © 2017, Texas Instruments Incorporated

Figure 6-8. Electrical Power-Steering Example

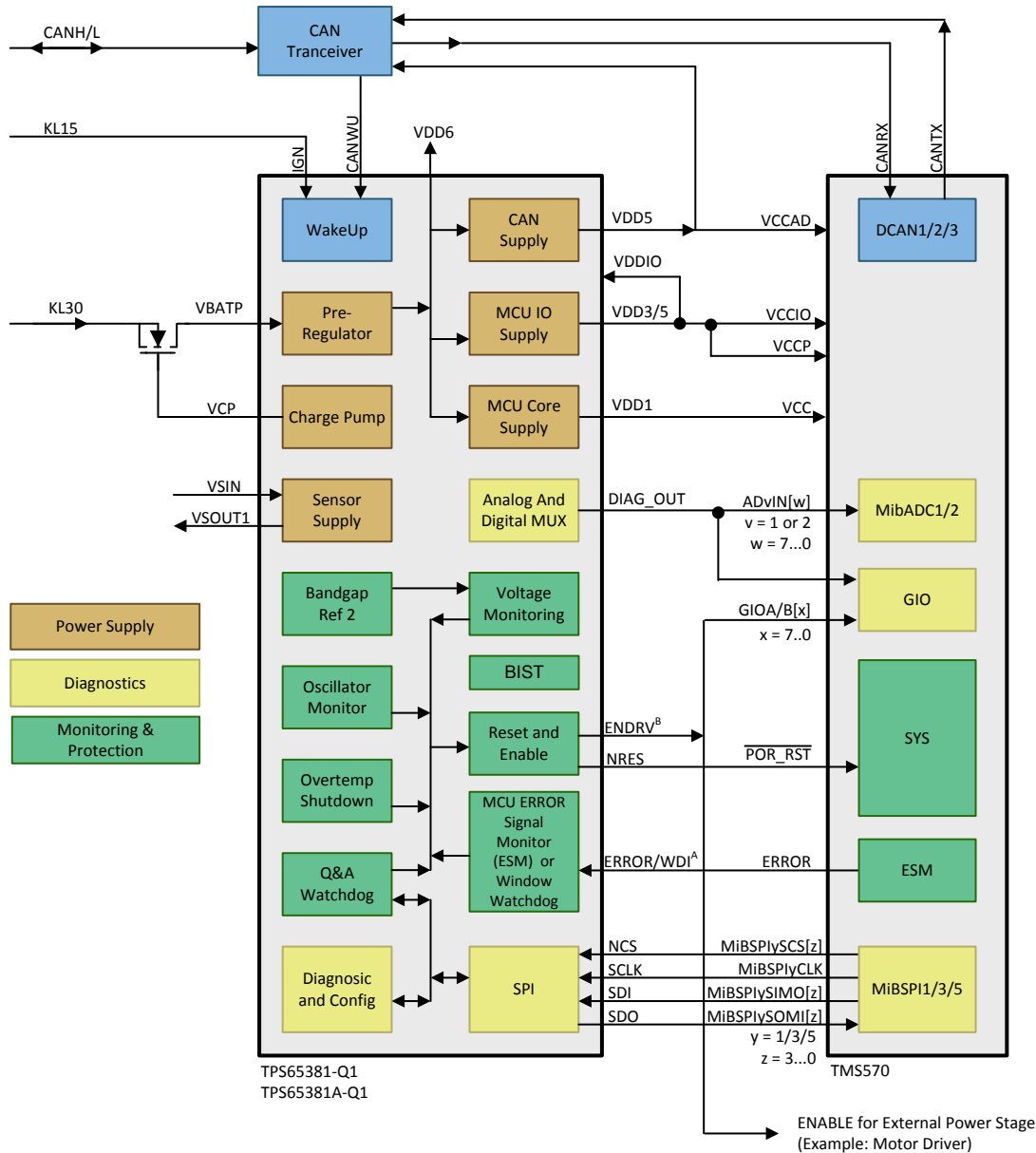

Copyright © 2017, Texas Instruments Incorporated

- The ERROR/WDI pin can be configured as an input for the MCU ERROR signal monitor (ESM) (TMS570 dual core or other safety architecture MCU) or as a window watchdog input (TMS470 or other single core MCU).
- The ENDRV output can be configured as either as ENABLE for the external power stage (typical use), or optionally as warm-RESET for the TMS570.

Figure 6-9. Example TPS65381-Q1 With TI's TMS570LS

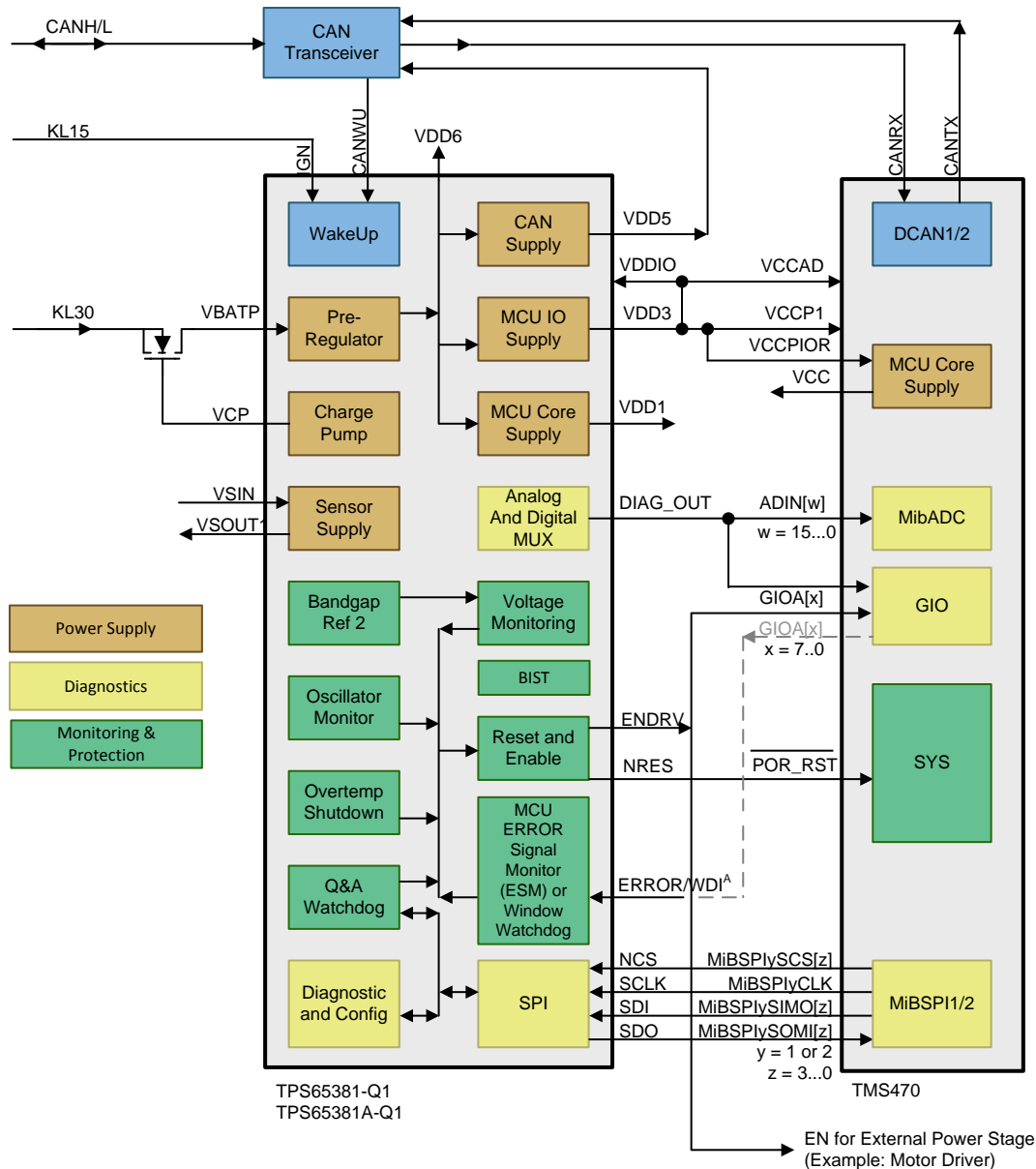

Copyright © 2017, Texas Instruments Incorporated

- A. The ERROR/WDI pin can be configured as an input for the MCU ERROR signal monitor (ESM) (TMS570 dual core or other safety architecture MCU) or as a window watchdog input (TMS470 or other single core MCU).

**Figure 6-10. Example TPS65381-Q1 With TI's TMS470 (Using an Internal MCU Core Supply)**

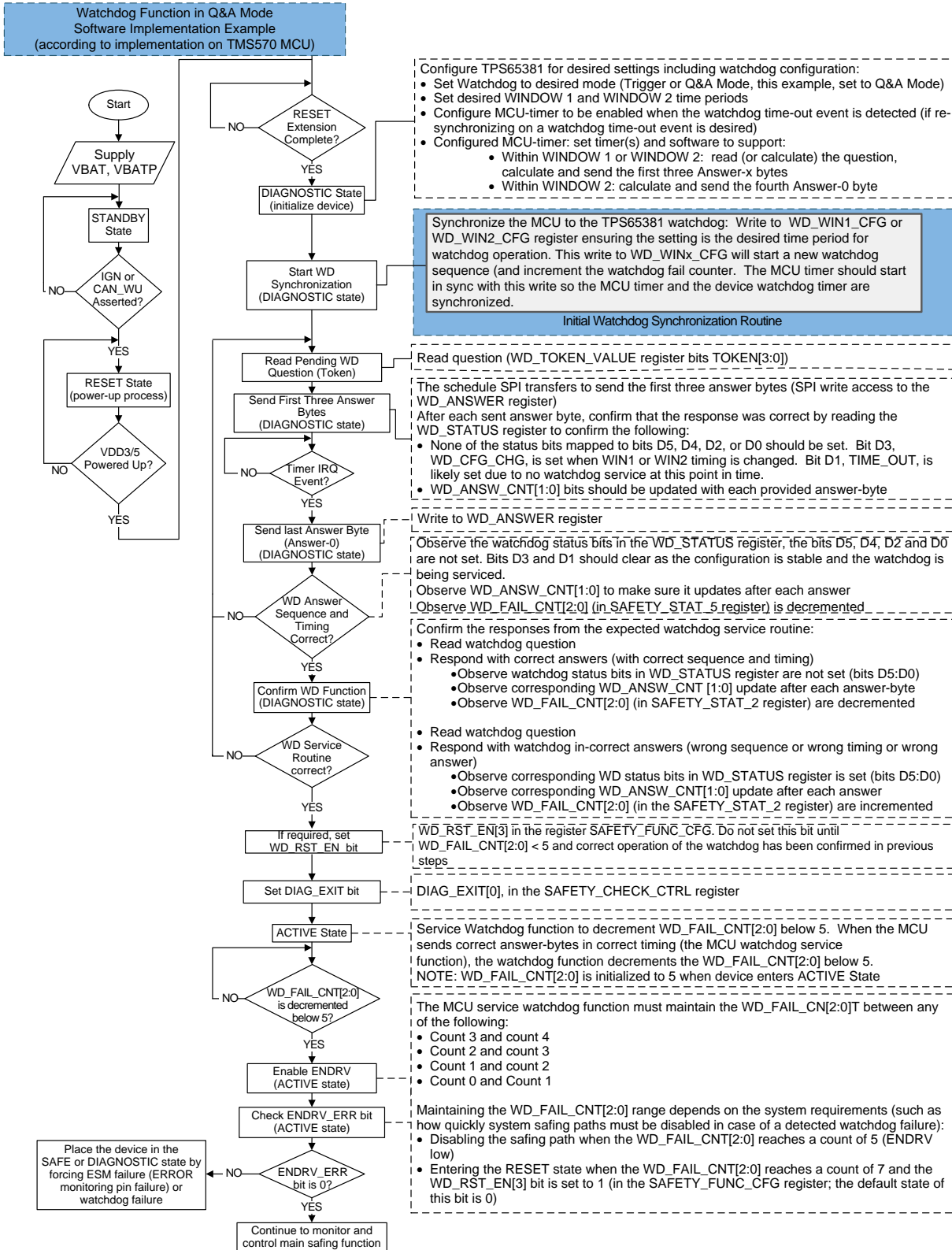

Figure 6-11. Software Flowchart for Configuring and Synchronizing the MCU With the Watchdog in Q&A Mode

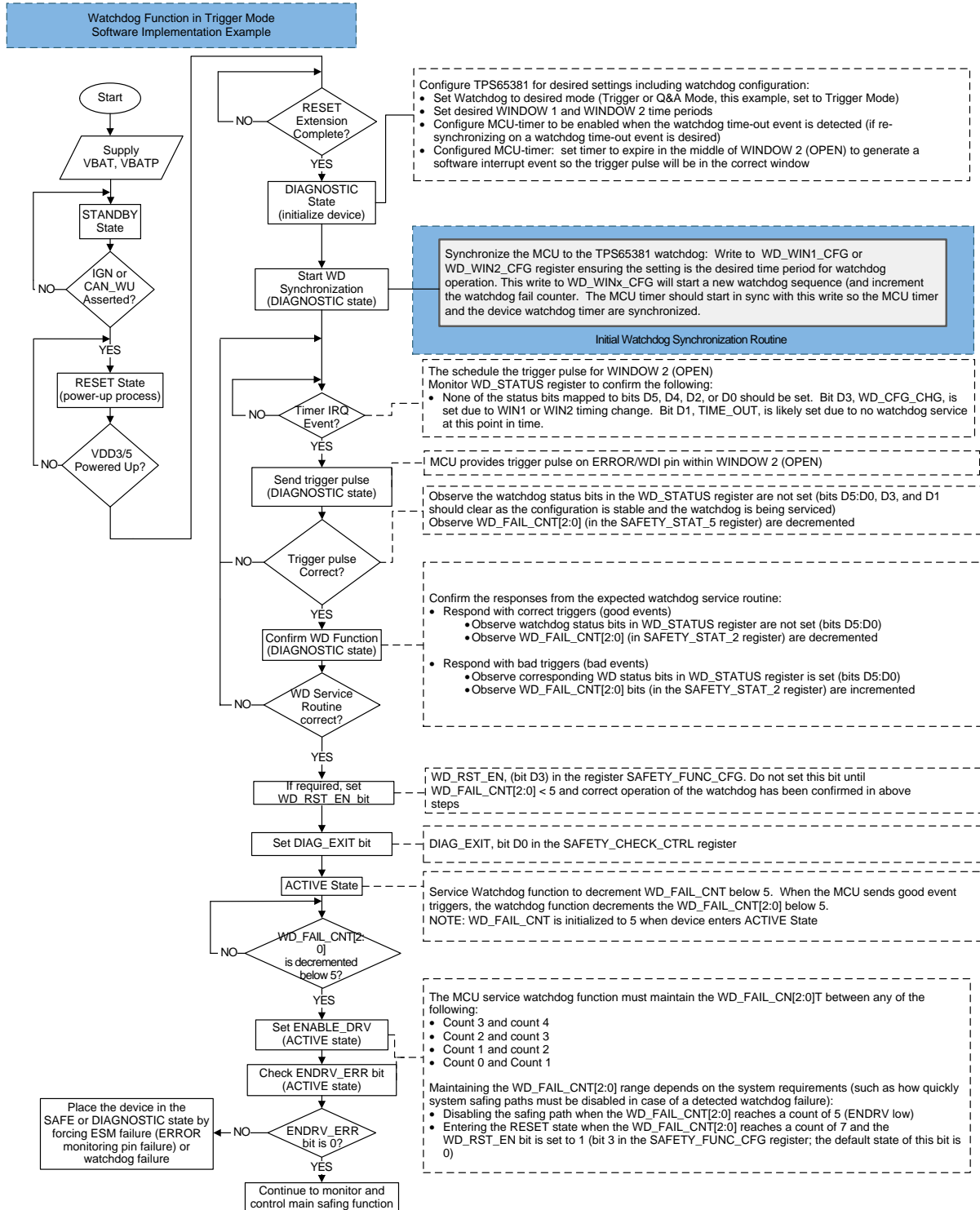

Figure 6-12. Software Flowchart for Configuring and Synchronizing the MCU With the Watchdog in Trigger Mode

## 7 Power Supply Recommendations

The TPS65381-Q1 device is designed to operate using an input supply voltage range from 5.8 V to 36 V (CAN, I/O, MCU core, and functional sensor-supply regulators) or 4.5 V to 5.8 V (3.3-V I/O and functional MCU-core voltage). The device has two supply pins: VBATP and VBAT\_SAFING. The VBATP pin is the main supply pin for the device. The VBAT\_SAFING supply pin is for monitoring (VMON) and BG2 functions. Both the VBATP and VBAT\_SAFING supplies must be reverse protected. The VBAT\_SAFING pin should be connected to the VBATP pin with a low impedance connection to minimize voltage differences between the device supply pins. For additional power supply recommendations, refer to the [TPS65381EVM User's Guide](#).

## 8 Layout

### 8.1 Layout Guidelines

#### 8.1.1 VDD6 Buck Preregulator

- Minimize the loop area for the switching loop of the inductor, ESR resistor, output capacitor, and diode.
- Minimize the parasitic trace impedance by using traces that are as wide as possible.
- Minimize the parasitic via impedance by using multiple vias, especially on high current and switching nodes.
- Connect the inductor and diode to SDN6 as close as possible to the pin.
- Connect the diode to PGND (ground plane).
- Connect the ESR resistor and output capacitor in series between VDD6 output (inductor output) and PGND.
- Connect the EMC filter capacitor between VDD6 output and PGND.
- Connect the VDD6 output to the VDD6 pin with routing to avoid coupling switching noise. Trace length should be minimized and as wide a trace as possible. This trace is the supply input to the downstream regulators using VDD6 as a preregulator, parasitic impedance should be minimized.

Additional consideration: add a footprint for a RC snubber circuit if one is required for the application. The RC connects in-series between the SDN6 and PGND pins.

#### 8.1.2 VDD1 Linear Regulator Controller

- Connect the drain of the external FET to VDD6 node, the trace should be minimized so that additional downstream buffering capacitors are not needed.
- Connect the output capacitor to the source of the external FET, the length of this trace should be minimized. Connect the output capacitor to the ground plane.
- Connect the gate drive, VDD1\_G, to the gate of the FET. Connect the resistor between the gate of the FET and the source of the FET, minimize the trace length.
- The resistor divider for sensing and setting the output voltage connects between the source of the FET (VDD1 output) and GND (device signal ground). Do not locate these components and their traces near the switching nodes or high-current traces.

#### 8.1.3 VDD5 and VDD3/5 Linear Regulators

Connect the output capacitor as close as possible between the VDDx output and GND.

### **8.1.4 VSOUT1 Tracking Linear Regulator**

- Connect the output capacitor as close as possible between the VSOUT1 output and GND.
- The resistor divider for sensing and setting the output voltage connects between the VSOUT1 and GND (device signal ground). Do not locate these components and their traces near the switching nodes or high-current traces.
- Connect the local decoupling capacitor between the VSIN and PGND pins. Minimize trace length.
- Route the tracking supply signal, connected to VTRACK1, away from switching nodes or high-current traces.

### **8.1.5 Charge Pump**

- Connect the capacitor as close as possible between the CP1 and CP2 pins.
- Connect the capacitor between the VCP pin and VBATP (reverse protected and filtered) supply.

### **8.1.6 Other Considerations**

- Use ground planes. TI recommends having a solid ground plane and connect GND and PGND with as low impedance paths as possible to the ground plane.
- Minimize parasitic impedance on the critical switching and high current paths.
- Short PGNDx and GND to the thermal pad.
- Use a star ground configuration if connecting to a non-ground plane system. Use tie-ins for the voltage-sense feedback ground and local biasing bypass capacitor ground networks to this star ground.
- Connect the local decoupling capacitor between VBATP and PGND. Minimize trace length.

## 8.2 Layout Example

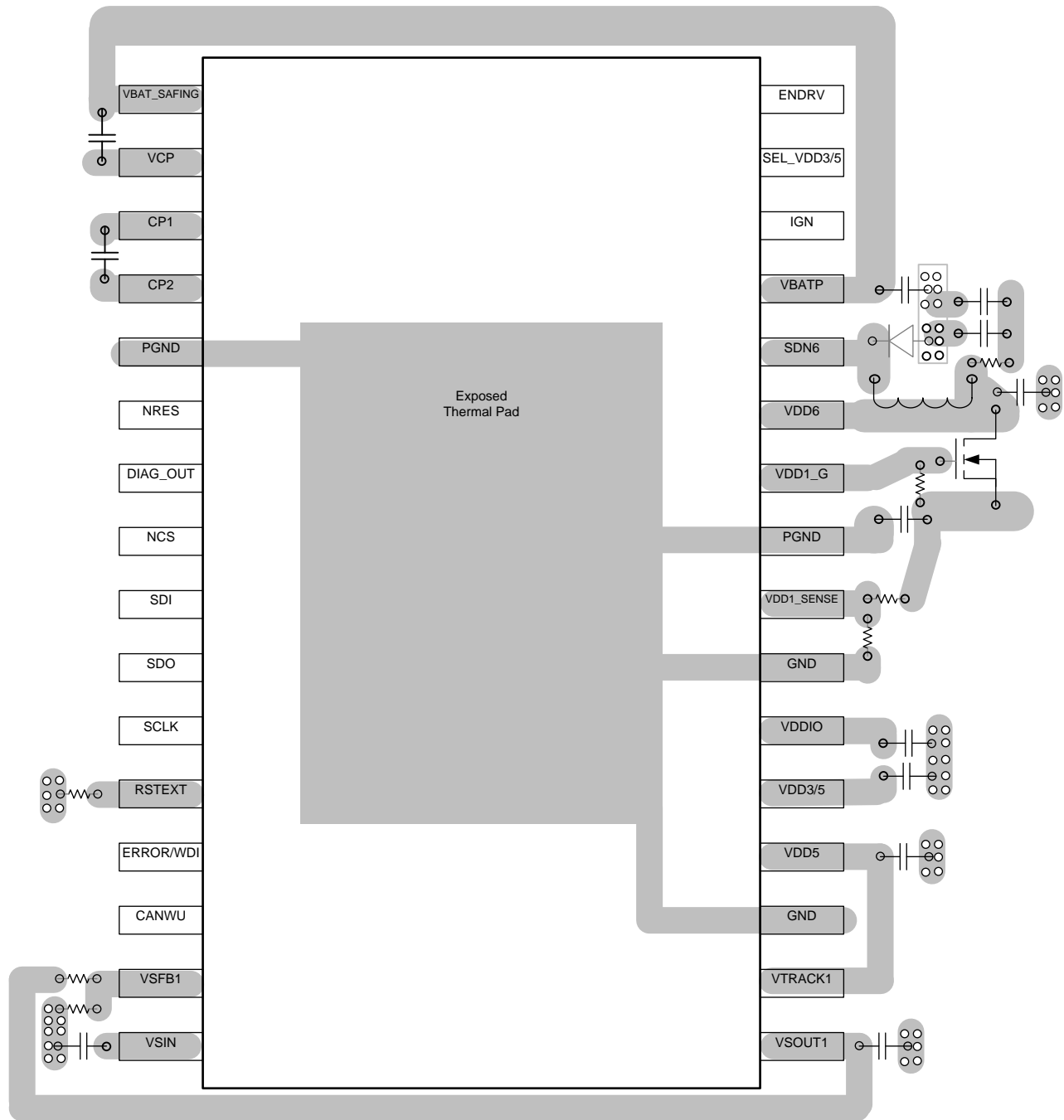

Figure 8-1. TPS65381-Q1 Board Layout

### 8.3 Power Dissipation and Thermal Considerations

The power dissipation of the device in the application has significant impact on the necessary layout and thermal management strategy of the application.

Use the following equations to calculate the estimated power dissipation in the device:

$$P_{VDD6} = (1 - \text{eff}_{VDD6}) \times 6 \text{ V} \times I_{VDD6}$$

where

- $P_{VDD6}$  is a conservative estimation of the power dissipation of VDD6 in the device because some of the efficiency loss is externally in the diode and inductor. A more accurate power estimator is available in the [TPS65381-Q1 and TPS65381A-Q1 Power Estimator](#).
- $\text{eff}_{VDD6}$  is the efficiency of VDD6 buck preregulator according to [Figure 8-2](#).
- $I_{VDD6}$  is the total load current from VDD5, VDD3/5, VDD1, VSOUT1 and any external load connected to VDD6. (26)

$$P_{VDD5} = (6 \text{ V} - 5 \text{ V}) \times I_{VDD5} = 1 \text{ V} \times I_{VDD5}$$

where

- $I_{VDD5}$  is the load current on VDD5. (27)

$$P_{VDD3/5} = (6 \text{ V} - V_{VDD3/5}) \times I_{VDD3/5}$$

where

- $V_{VDD3/5}$  is either 3.3 V or 5 V.
- $I_{VDD3/5}$  is the load current on VDD3/5. (28)

$$P_{VSOUT1} = (V_{VSIN} - V_{VSOUT1}) \times I_{VSOUT1}$$

where

- $V_{VSIN}$  is either 6 V (VDD6) or VBATP.
- $V_{VSOUT1}$  is the programmed output voltage of VSOUT1.
- $I_{VSOUT1}$  is the load current on VSOUT1 (29)

$$P_{TOT} = P_{VDD6} + P_{VDD5} + P_{VDD3/5} + P_{VSOUT1}$$

where

- $P_{TOT}$  is the total power dissipation in the device. (30)

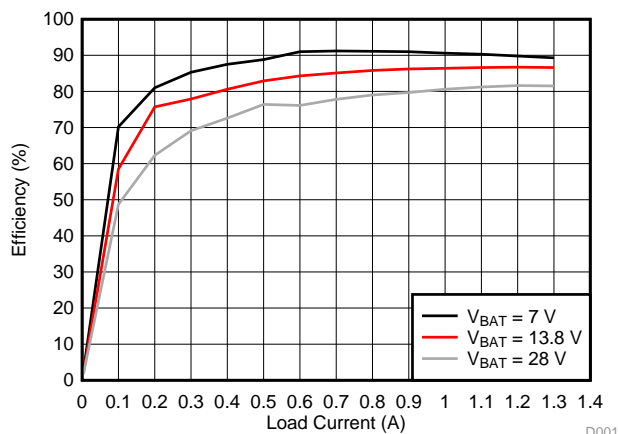

Figure 8-2. Typical VDD6 BUCK Efficiency

The useful range of device operation is affected by the supply voltage, application load-current requirements, and the thermal characteristics of the package and printed circuit board (PCB). For the device to be useful over a wide temperature range, the package, PCB and thermal management strategy must allow for the effective removal of the produce heat to keep junction temperature of the device within rated limits.

Use Equation 26 to Equation 30 to calculate the estimated power dissipation. As shown by the equation for VDD6 power dissipation (PVDD6), Equation 27, a large portion of the power dissipation is determined by the efficiency of the VDD6 supply. The efficiency of the VDD6 supply depends on load current and supply voltage as shown in Equation 27.

The 32-pin HTSSOP PowerPAD (DAP) offers an effective means of removing heat from the device junction. As described in *PowerPad™ Thermally Enhanced Package*, the PowerPAD package offers a lead-frame die pad that is exposed at the base of the package. This thermal pad must be soldered to the copper on the PCB directly underneath the package to create an effective path for removal of heat from the device, and, therefore, to reduce the  $R_{\theta JC}$ . The PCB must be designed with thermal lands and thermal vias to complete the heat removal subsystem, as summarized in *PowerPAD™ Made Easy* and *A Guide to Board Layout for Best Thermal Resistance for Exposed Packages*.

Figure 8-3 shows the thermal derating profile of the 32-pin HTSSOP (DCA) Package With PowerPAD according to  $R_{\theta JA}$  as specified in Section 4.4.

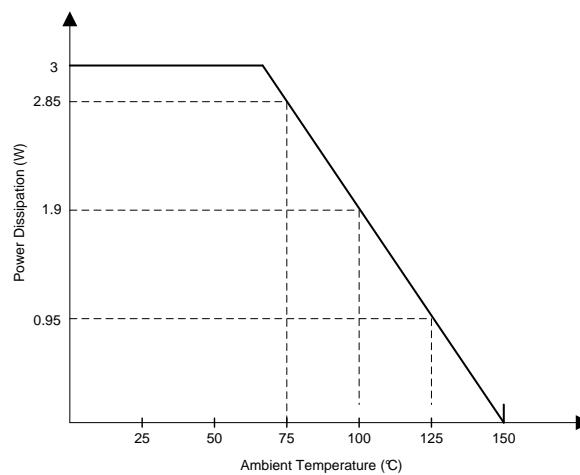

- A. In applications where high power dissipation and/or poor package thermal resistance is present, the maximum ambient temperature may have to be derated. Maximum ambient temperature ( $T_{Amax}$ ) is dependent on the maximum-operating junction temperature ( $T_{Jmax}$ ), the maximum power dissipation of the device in the application ( $P_{Dmax}$ ), and the junction-to-ambient thermal resistance of the part/package in the application ( $R_{\theta JA}$ ), as given by the following equation:  $T_{Amax} = T_{Jmax} - (R_{\theta JA} \times P_{Dmax})$ .
- B. Maximum power dissipation is a function of  $T_{Jmax}$ ,  $R_{\theta JA}$ , and  $T_A$ . The maximum-allowable power dissipation at any allowable ambient temperature is  $P_D = (T_{Jmax} - T_A) / R_{\theta JA}$ .

**Figure 8-3. Derating Profile for Power Dissipation Based on High-K JEDEC PCB**

Considering the power dissipation of the device in the specific application is important, which is highly dependent on the supply voltage and load currents, the ambient and board temperatures, and any additional heat sink or cooling strategies necessary to maintain the junction temperature of the device below the maximum junction temperature of 150°C.

**NOTE**

The VDD1 regulator may have significant power dissipation in the external FET depending on the VDD1 voltage and load current. The external FET power dissipation for the VDD1 regulator must be considered in system-level thermal analysis. If better efficiency or thermal performance is needed, a DC-DC regulator could be used instead of the linear regulator controller with external FET. The output voltage of the DC-DC regulator can still be monitored by the VDD1\_SENSE pin similar to the VDD1 output voltage when the VDD1 linear regulator controller is used with an external FET.

---

**NOTE**

The PowerPAD thermal pad is not directly connected to any leads of the package. However, it is electrically and thermally connected to the substrate, which is the ground (GND) and power ground (PGND) of the device.

---

**NOTE**

Additional information about thermal analysis and design can be found on [www.ti.com](http://www.ti.com) in the [WEBENCH® Design Center](#) thermal analysis section.

---

## 9 Device and Documentation Support

### 9.1 Device Support

#### 9.1.1 Third-Party Products Disclaimer

TI'S PUBLICATION OF INFORMATION REGARDING THIRD-PARTY PRODUCTS OR SERVICES DOES NOT CONSTITUTE AN ENDORSEMENT REGARDING THE SUITABILITY OF SUCH PRODUCTS OR SERVICES OR A WARRANTY, REPRESENTATION OR ENDORSEMENT OF SUCH PRODUCTS OR SERVICES, EITHER ALONE OR IN COMBINATION WITH ANY TI PRODUCT OR SERVICE.

### 9.2 Documentation Support

#### 9.2.1 Related Documentation

For related documentation, see the following:

- [Device Behavior Under Slow VBAT Ramp-Up and Ramp-Down](#)
- [DPI Evaluation TPS65381-Q1](#)
- [Efficiency Evaluation TPS65381-Q1](#)
- [Safety Manual for TPS65381-Q1 and TPS65381A-Q1 Multirail Power Supply](#)
- [TPS65381EVM User's Guide](#)
- [TPS65381-Q1 and TPS65381A-Q1 Design Checklist](#)
- [TPS65381-Q1 and TPS65381A-Q1 Power Estimator](#)

### 9.3 Receiving Notification of Documentation Updates

To receive notification of documentation updates, navigate to the device product folder on ti.com. In the upper right corner, click on *Alert me* to register and receive a weekly digest of any product information that has changed. For change details, review the revision history included in any revised document.

### 9.4 Community Resources

The following links connect to TI community resources. Linked contents are provided "AS IS" by the respective contributors. They do not constitute TI specifications and do not necessarily reflect TI's views; see TI's [Terms of Use](#).

**TI E2E™ Online Community** The TI engineer-to-engineer (E2E) community was created to foster collaboration among engineers. At [e2e.ti.com](http://e2e.ti.com), you can ask questions, share knowledge, explore ideas and help solve problems with fellow engineers.

**Design Support** *TI's Design Support* Quickly find helpful E2E forums along with design support tools and contact information for technical support.

### 9.5 Trademarks

Hercules, C2000, PowerPAD, E2E are trademarks of Texas Instruments. All other trademarks are the property of their respective owners.

## 9.6 Electrostatic Discharge Caution



This integrated circuit can be damaged by ESD. Texas Instruments recommends that all integrated circuits be handled with appropriate precautions. Failure to observe proper handling and installation procedures can cause damage.

ESD damage can range from subtle performance degradation to complete device failure. Precision integrated circuits may be more susceptible to damage because very small parametric changes could cause the device not to meet its published specifications.

## 9.7 Glossary

[TI Glossary](#) This glossary lists and explains terms, acronyms, and definitions.

## 10 Mechanical, Packaging, and Orderable Information

The following pages include mechanical packaging and orderable information. This information is the most current data available for the designated devices. This data is subject to change without notice and revision of this document. For browser-based versions of this data sheet, refer to the left-hand navigation.

**PACKAGING INFORMATION**

Orderable Device	Status (1)	Package Type	Package Drawing	Pins	Package Qty	Eco Plan (2)	Lead finish/ Ball material (6)	MSL Peak Temp (3)	Op Temp (°C)	Device Marking (4/5)	Samples
TPS65381QDAPRQ1	NRND	HTSSOP	DAP	32	2000	RoHS & Green	NIPDAU	Level-3-260C-168 HR	-40 to 125	TPS65381	

(1) The marketing status values are defined as follows:

**ACTIVE:** Product device recommended for new designs.

**LIFEBUY:** TI has announced that the device will be discontinued, and a lifetime-buy period is in effect.

**NRND:** Not recommended for new designs. Device is in production to support existing customers, but TI does not recommend using this part in a new design.

**PREVIEW:** Device has been announced but is not in production. Samples may or may not be available.

**OBSELETE:** TI has discontinued the production of the device.

(2) **RoHS:** TI defines "RoHS" to mean semiconductor products that are compliant with the current EU RoHS requirements for all 10 RoHS substances, including the requirement that RoHS substance do not exceed 0.1% by weight in homogeneous materials. Where designed to be soldered at high temperatures, "RoHS" products are suitable for use in specified lead-free processes. TI may reference these types of products as "Pb-Free".

**RoHS Exempt:** TI defines "RoHS Exempt" to mean products that contain lead but are compliant with EU RoHS pursuant to a specific EU RoHS exemption.

**Green:** TI defines "Green" to mean the content of Chlorine (Cl) and Bromine (Br) based flame retardants meet JS709B low halogen requirements of <=1000ppm threshold. Antimony trioxide based flame retardants must also meet the <=1000ppm threshold requirement.

(3) MSL, Peak Temp. - The Moisture Sensitivity Level rating according to the JEDEC industry standard classifications, and peak solder temperature.

(4) There may be additional marking, which relates to the logo, the lot trace code information, or the environmental category on the device.

(5) Multiple Device Markings will be inside parentheses. Only one Device Marking contained in parentheses and separated by a "-" will appear on a device. If a line is indented then it is a continuation of the previous line and the two combined represent the entire Device Marking for that device.

(6) Lead finish/Ball material - Orderable Devices may have multiple material finish options. Finish options are separated by a vertical ruled line. Lead finish/Ball material values may wrap to two lines if the finish value exceeds the maximum column width.

**Important Information and Disclaimer:**The information provided on this page represents TI's knowledge and belief as of the date that it is provided. TI bases its knowledge and belief on information provided by third parties, and makes no representation or warranty as to the accuracy of such information. Efforts are underway to better integrate information from third parties. TI has taken and continues to take reasonable steps to provide representative and accurate information but may not have conducted destructive testing or chemical analysis on incoming materials and chemicals. TI and TI suppliers consider certain information to be proprietary, and thus CAS numbers and other limited information may not be available for release.

In no event shall TI's liability arising out of such information exceed the total purchase price of the TI part(s) at issue in this document sold by TI to Customer on an annual basis.

## TAPE AND REEL INFORMATION

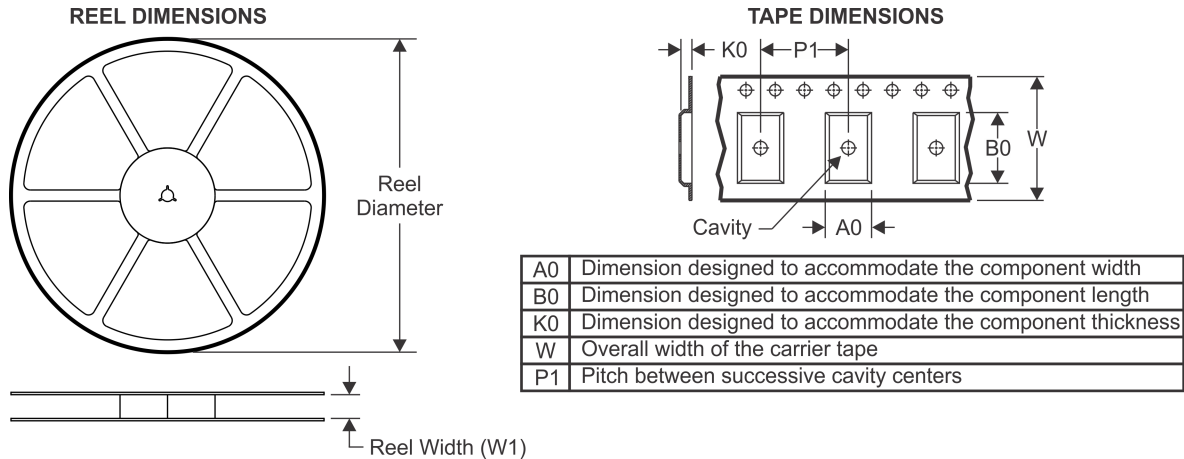

### QUADRANT ASSIGNMENTS FOR PIN 1 ORIENTATION IN TAPE

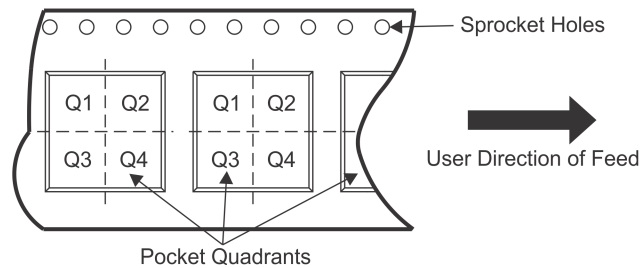

\*All dimensions are nominal

Device	Package Type	Package Drawing	Pins	SPQ	Reel Diameter (mm)	Reel Width W1 (mm)	A0 (mm)	B0 (mm)	K0 (mm)	P1 (mm)	W (mm)	Pin1 Quadrant
TPS65381QDAPRQ1	HTSSOP	DAP	32	2000	330.0	24.4	8.6	11.5	1.6	12.0	24.0	Q1

**TAPE AND REEL BOX DIMENSIONS**

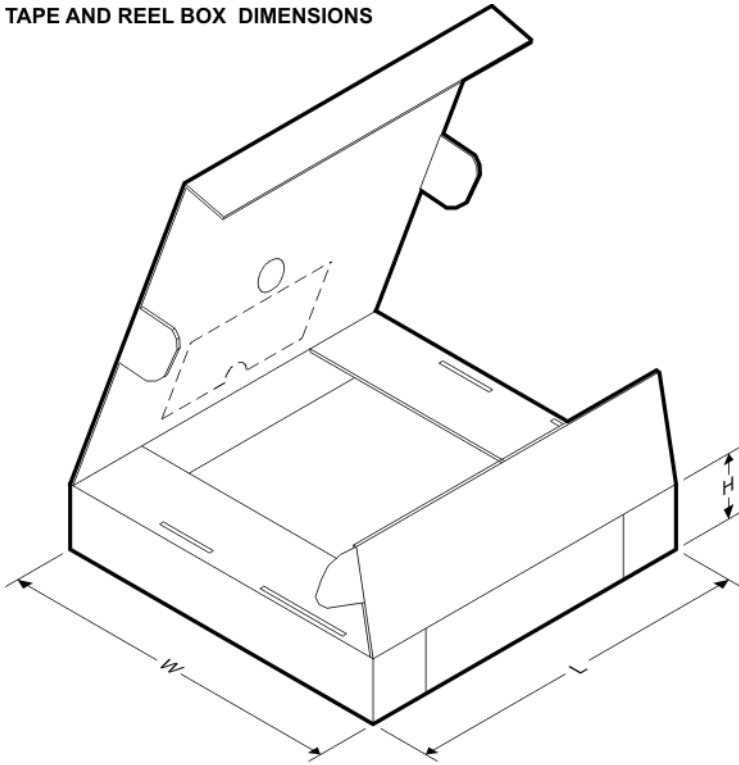

\*All dimensions are nominal

Device	Package Type	Package Drawing	Pins	SPQ	Length (mm)	Width (mm)	Height (mm)
TPS65381QDAPRQ1	HTSSOP	DAP	32	2000	350.0	350.0	43.0

## GENERIC PACKAGE VIEW

**DAP 32**

**PowerPAD™ TSSOP - 1.2 mm max height**

8.1 x 11, 0.65 mm pitch

PLASTIC SMALL OUTLINE

This image is a representation of the package family, actual package may vary.  
Refer to the product data sheet for package details.

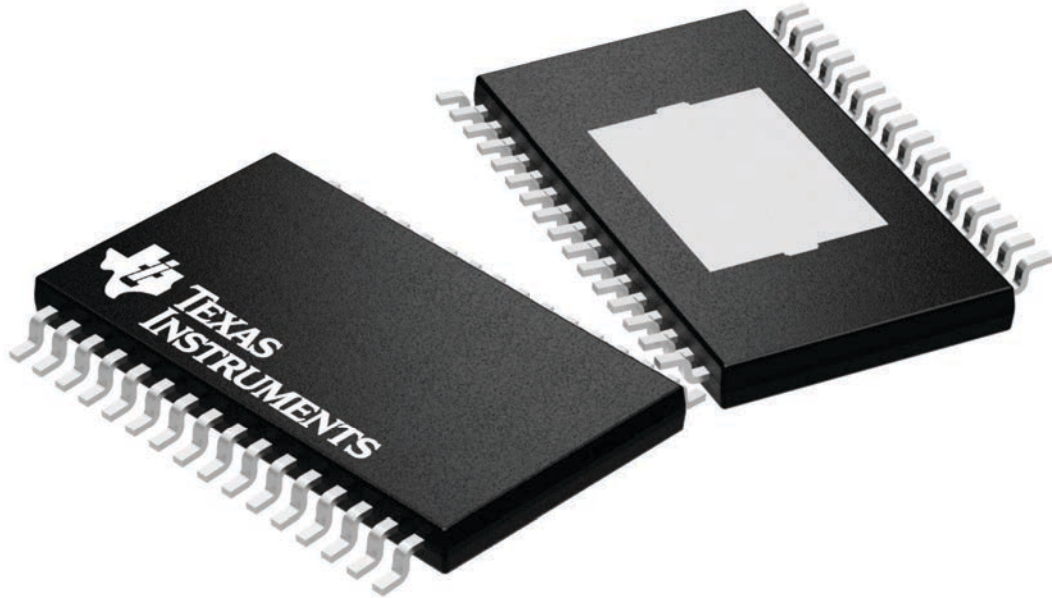

4225303/A

# DAP0032B

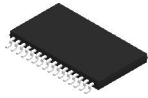

# PACKAGE OUTLINE

## PowerPAD™ TSSOP - 1.2 mm max height

PLASTIC SMALL OUTLINE

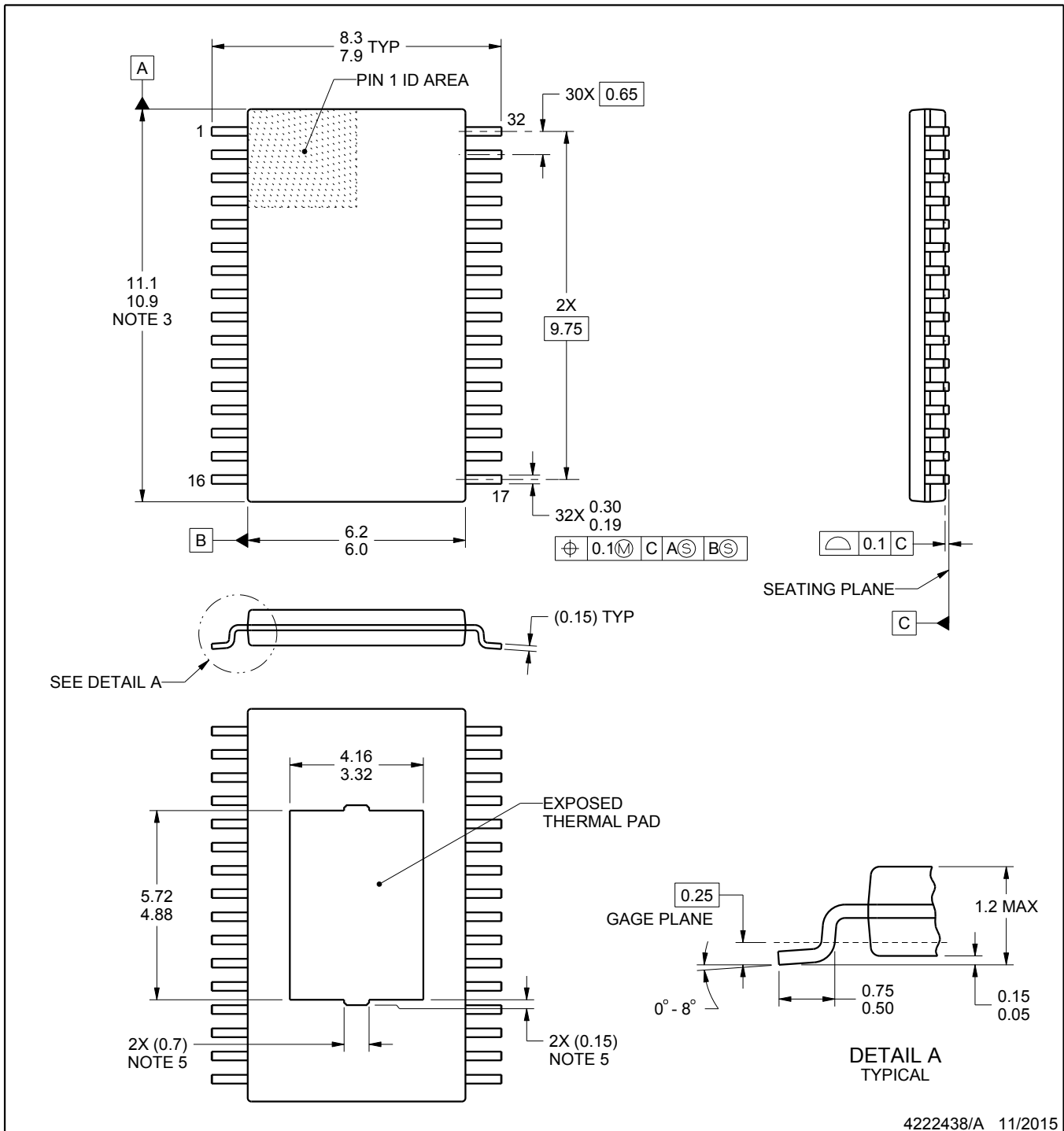

4222438/A 11/2015

### NOTES:

PowerPAD is a trademark of Texas Instruments.

1. All linear dimensions are in millimeters. Any dimensions in parenthesis are for reference only. Dimensioning and tolerancing per ASME Y14.5M.
2. This drawing is subject to change without notice.
3. This dimension does not include mold flash, protrusions, or gate burrs. Mold flash, protrusions, or gate burrs shall not exceed 0.15 mm per side.
4. Reference JEDEC registration MO-153, variation DCT.
5. Features may not present.

# EXAMPLE BOARD LAYOUT

DAP0032B

PowerPAD™ TSSOP - 1.2 mm max height

PLASTIC SMALL OUTLINE

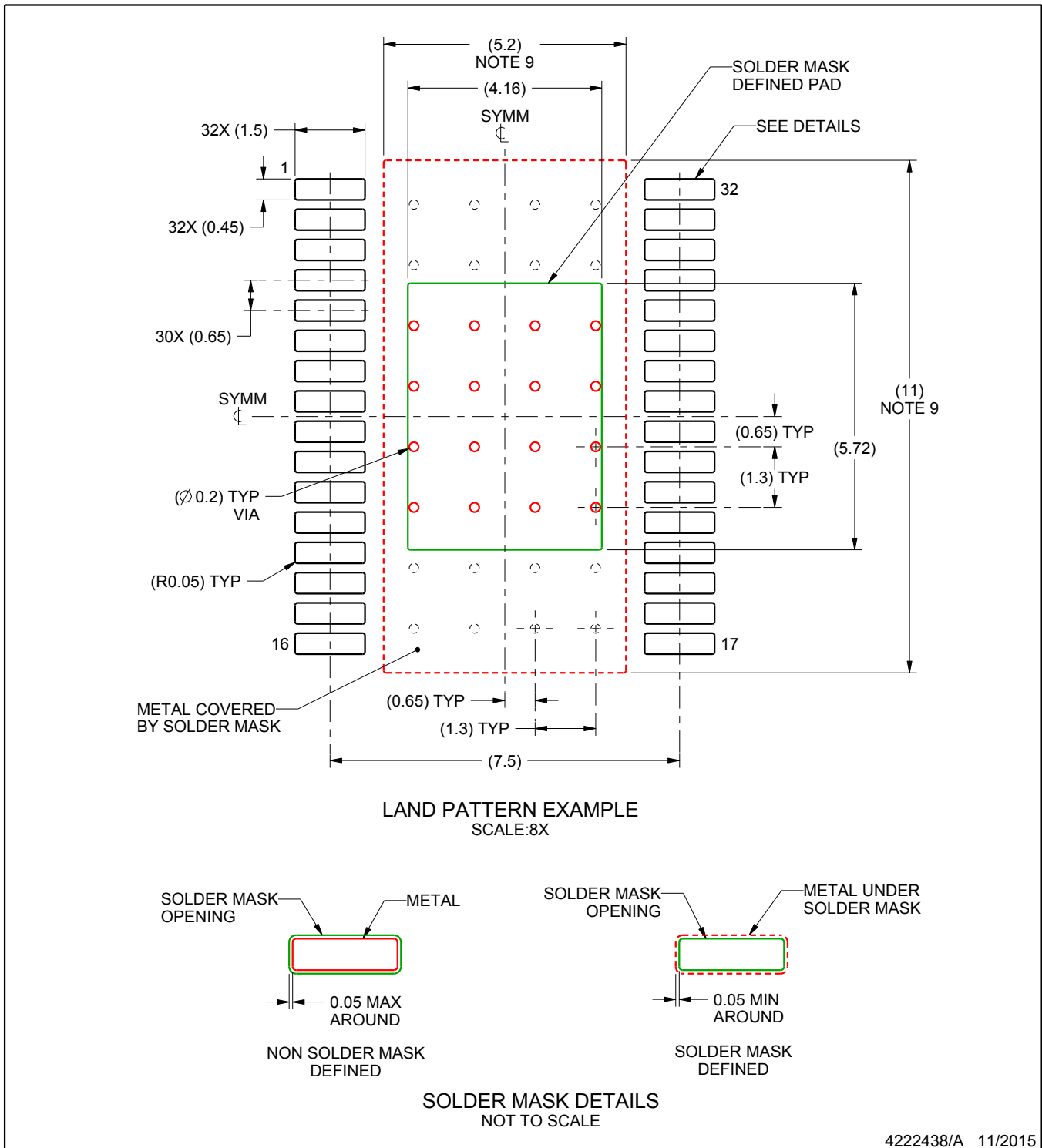

4222438/A 11/2015

NOTES: (continued)

6. Publication IPC-7351 may have alternate designs.
7. Solder mask tolerances between and around signal pads can vary based on board fabrication site.
8. This package is designed to be soldered to a thermal pad on the board. For more information, see Texas Instruments literature numbers SLMA002 ([www.ti.com/lit/slma002](http://www.ti.com/lit/slma002)) and SLMA004 ([www.ti.com/lit/slma004](http://www.ti.com/lit/slma004)).
9. Size of metal pad may vary due to creepage requirement.

# EXAMPLE STENCIL DESIGN

DAP0032B

PowerPAD™ TSSOP - 1.2 mm max height

PLASTIC SMALL OUTLINE

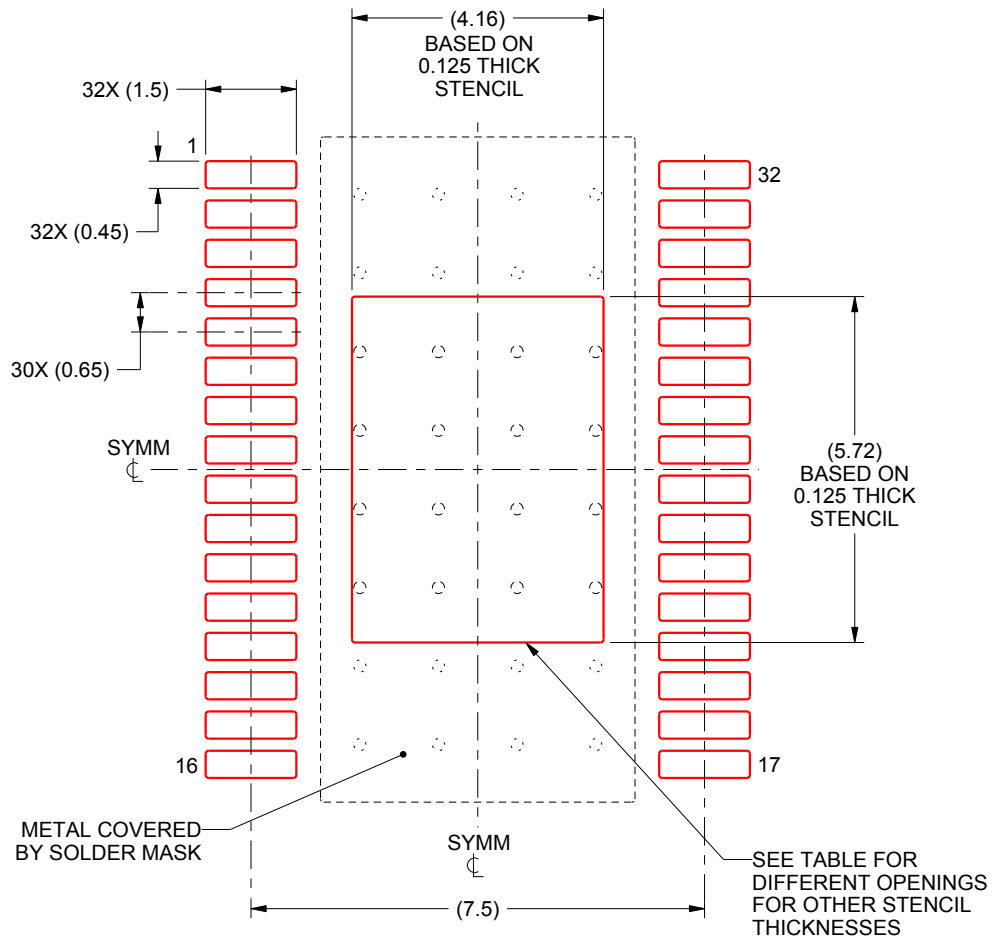

**SOLDER PASTE EXAMPLE**  
 EXPOSED PAD  
 100% PRINTED SOLDER COVERAGE BY AREA  
 SCALE:8X

STENCIL THICKNESS	SOLDER STENCIL OPENING
0.1	4.65 X 6.4
0.125	4.16 X 5.72 (SHOWN)
0.15	3.8 X 5.22
0.175	3.52 X 4.83

4222438/A 11/2015

NOTES: (continued)

- 10. Laser cutting apertures with trapezoidal walls and rounded corners may offer better paste release. IPC-7525 may have alternate design recommendations.
- 11. Board assembly site may have different recommendations for stencil design.

## IMPORTANT NOTICE AND DISCLAIMER

TI PROVIDES TECHNICAL AND RELIABILITY DATA (INCLUDING DATASHEETS), DESIGN RESOURCES (INCLUDING REFERENCE DESIGNS), APPLICATION OR OTHER DESIGN ADVICE, WEB TOOLS, SAFETY INFORMATION, AND OTHER RESOURCES "AS IS" AND WITH ALL FAULTS, AND DISCLAIMS ALL WARRANTIES, EXPRESS AND IMPLIED, INCLUDING WITHOUT LIMITATION ANY IMPLIED WARRANTIES OF MERCHANTABILITY, FITNESS FOR A PARTICULAR PURPOSE OR NON-INFRINGEMENT OF THIRD PARTY INTELLECTUAL PROPERTY RIGHTS.

These resources are intended for skilled developers designing with TI products. You are solely responsible for (1) selecting the appropriate TI products for your application, (2) designing, validating and testing your application, and (3) ensuring your application meets applicable standards, and any other safety, security, or other requirements. These resources are subject to change without notice. TI grants you permission to use these resources only for development of an application that uses the TI products described in the resource. Other reproduction and display of these resources is prohibited. No license is granted to any other TI intellectual property right or to any third party intellectual property right. TI disclaims responsibility for, and you will fully indemnify TI and its representatives against, any claims, damages, costs, losses, and liabilities arising out of your use of these resources.

TI's products are provided subject to TI's Terms of Sale ([www.ti.com/legal/termsofsale.html](http://www.ti.com/legal/termsofsale.html)) or other applicable terms available either on [ti.com](http://ti.com) or provided in conjunction with such TI products. TI's provision of these resources does not expand or otherwise alter TI's applicable warranties or warranty disclaimers for TI products.

Mailing Address: Texas Instruments, Post Office Box 655303, Dallas, Texas 75265  
Copyright © 2020, Texas Instruments Incorporated